

3M™ Cold Shrink QT-III Silicone Rubber Skirted Termination Kit

With High-K Stress Relief

For Tape Shield, Wire Shield and UniShield® Cable

7686-S-8

Instructions

IEEE Std. No. 48

Class 1 Termination

35 kV Class

200 kV BIL

CAUTION

Working around energized systems may cause serious injury or death. Installation should be performed by personnel familiar with good safety practice in handling electrical equipment. De-energize and ground all electrical systems before installing product.

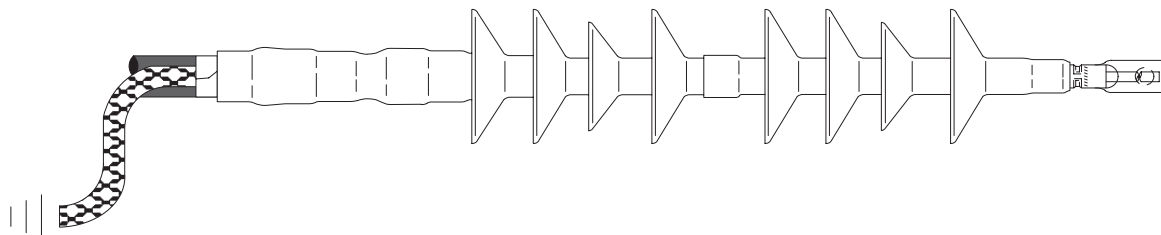

1.0 Kit Contents

- 3 High-K, Tracking Resistant, Silicone Rubber Terminations
- 3 Pre-formed Ground Braids
- 3 Constant Force Springs
- 3 3M EMI Copper Foil Shielding Tape 1181 Strips, 1/2" x 10"
- 6 Strips Scotch® Mastic Strip 2230 (black with white release liners, bagged)
- 1 3M Cable Cleaning Preparation Kit CC-2
- 1 Instruction Sheet

Note: Do not use knives to open plastic bags.

Kit Selection Tables

NOTE: Final Determination Factor is cable insulation diameter.

| For Use With Compression Lugs or Connectors | | | | | |
|---|-----------------------------------|-----------------------------------|--|--|--|
| Kit Number | Primary Insulation O.D. Range | Jacket O.D. Range | Conductor Size Range (AWG & kcmil) | | |
| | | | 15 kV | 25/28 kV | 35 kV |
| 7686-S-8 | 1.53" – 2.32" (38,9 – 58,9 mm) | 1.84" – 2.80" (46,8 – 71,1 mm) | 1250 – 2000 kcmil (625 – 1000 mm ²) | 900 – 1750 kcmil (500 – 800 mm ²) | 700 – 1500 kcmil (400 – 725 mm ²) |

Table 1

| For Use With 3M™ Mechanical Shearbolt Lugs QL2 Series: Two Hole | | | | | | |
|---|-----------------------------------|-----------------------------------|------------------------------------|--|--|--|
| Kit Number | Primary Insulation O.D. Range | Jacket O.D. Range | Conductor Size Range (AWG & kcmil) | | | 3M™ Mechanical Shearbolt Lugs QL2 Series: Two Hole Part Number |
| | | | 15 kV | 25/28 kV | 35 kV | |
| 7686-S-8 | 1.53" - 2.32" (38,9 - 58,9 mm) | 1.84" - 2.80" (46,8 - 71,1 mm) | ----- | ----- | 750 (400 mm ²) | QL2-A-350-750 |
| 7686-S-8 | 1.53" - 2.32" (38,9 - 58,9 mm) | 1.84" - 2.80" (46,8 - 71,1 mm) | ----- | ----- | 750 -1000 (400 - 500 mm ²) | QL2-A-500-1000 |
| 7686-S-8 | 1.53" - 2.32" (38,9 - 58,9 mm) | 1.84" - 2.80" (46,8 - 71,1 mm) | 1250 (625 mm ²) | 1000 -1250 (600 - 625 mm ²) | 1000 -1250 (600 - 625 mm ²) | QL2-A-1000-1250 |

Table 2

2.0 Instructions for Tape Shielded Cable

Prepare Cable

- 2.1 Check to be sure cable size fits within kit range as shown in Table 1. (For Use With Compression Lugs or Connectors), or Table 2 (For Use With 3M Mechanical Shearbolt Lugs QL2 Series: Two Hole). Refer to Table 4 for semi-con cutback dimension.
- 2.2 Prepare cable using dimensions shown in Figure 1. **BE SURE TO ALLOW FOR DEPTH OF TERMINAL LUG OR CONNECTOR.** If necessary to prevent tape shield from unrolling, hold down edge with a single wrap of 3M EMI Copper Foil Shielding Tape 1181. If using 3M Shearbolt Lugs QL2 Series: Two Hole, or 3M Mechanical Shearbolt Connector QCI Series, proceed to Step 2.3. If using a Crimp Type (Compression) lug, measure the depth of the barrel, or if using a Crimp Type (Compression) connector, measure to the barrel center stop/midpoint, and see the NOTE below in order to calculate the Insulation Removal Length. Table 5 can be used to assist in calculating the total Jacket Removal Length when using a compression lug or connector

NOTE: Provide additional exposed conductor distance to account for growth during crimping of ALUMINUM lugs or connectors as follows:

| Aluminum Lug and Connector Growth Allowance | 2 - 350 1/4" (6 mm) | 400 - 650 1/2" (13 mm) | 750-1000 3/4" (19 mm) | 1250 - 2000 Field determined |
|---|------------------------|---------------------------|--------------------------|---------------------------------|
|---|------------------------|---------------------------|--------------------------|---------------------------------|

Table 3

NOTE: It is imperative to remove all remnants of the semi-con layer, even if the semi-con layer comes off as one layer. There should not be any remaining black areas, or particles, on the cable insulation layer.

| Kit Numbers | Insulation O.D. | 15 kV AWG / kcmil | 25/28 kV AWG / kcmil | 35 kV AWG / kcmil | Semi-con Cutback |
|-------------|-----------------------------------|--|---|---|---------------------|
| 7686-S-8 | 1.53" – 1.85" (38,9 – 47,0 mm) | 1250 (625 mm ²) | 900 – 1000 (500 mm ²) | 700 – 900 (400 mm ²) | 13.5" (342,9 mm) |
| | 1.65" – 2.32" (42,0 – 58,9 mm) | 1500 – 2000 (630 – 1000 mm ²) | 1250 – 1750 (625 – 800 mm ²) | 1000 – 1500 (500 – 725 mm ²) | 13.0" (330,2 mm) |

Table 4

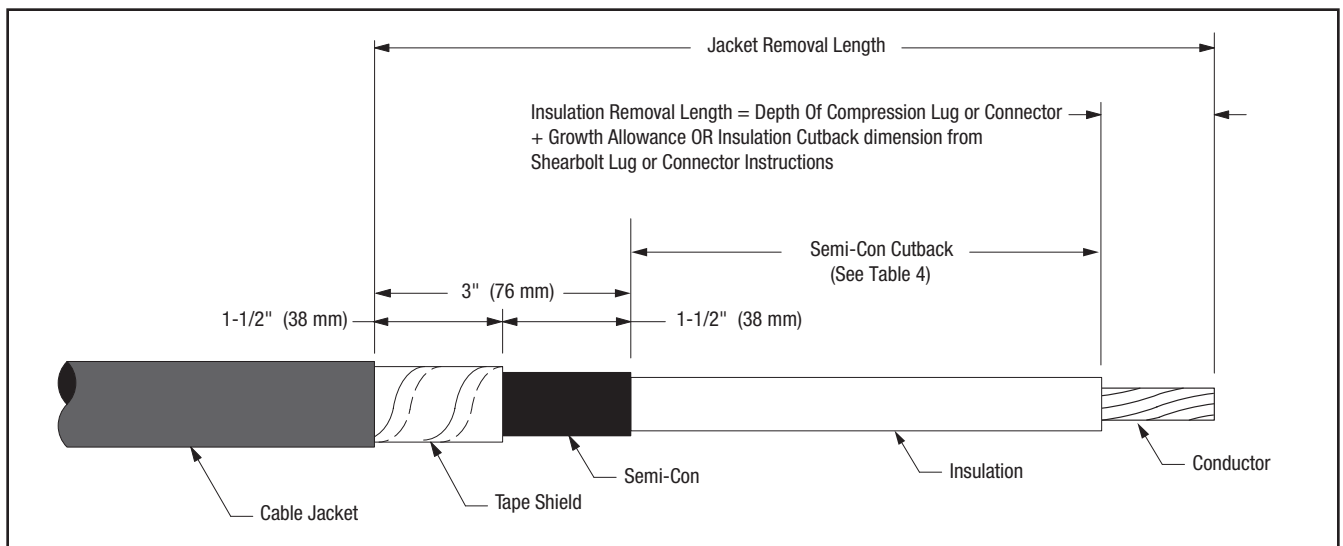

Figure 1

3M™ Cold Shrink QT-III Silicone Rubber Skirted Termination Kit With High-K Stress Relief

| Jacket Removal Calculation Table - Tape Shield Cable - Crimp Type (Compression) Lugs / Connectors - 7686-S-8 | | | |
|--|---------------------------------------|---------------------------------------|---|
| CABLE PREPARATION ITEM | Inches -Add this column- | mm -Add this column- | NOTES |
| Insulation Length | See NOTES Column for this Value | See NOTES Column for this Value | Refer to Table 4; • If using the 13.5" (342,9 mm) Semi-con cutback, enter 16.5" (419,1 mm) in the Insulation Length box. • If using the 13.0" (330,2 mm) Semi-con cutback, enter 16.0" (342,9 mm) in the Insulation Length box. |
| Insulation Removal Length = Depth of Crimp Type (Compression) Terminal Lug or Connector Barrel (See NOTES column.) | + | + | Measure full depth of bore for lugs and to the center stop for connectors. |
| Growth Allowance (Aluminum Only) for Crimp Type (Compression) Lug / Connector (See NOTES column.) | + | + | See Table 3 for correct growth allowance. This measurement applies only to Aluminum lugs / connectors. |
| TOTAL JACKET REMOVAL LENGTH | = | = | |

Table 5

2.3 If using 3M Mechanical Shearbolt Lugs QL2 Series: Two Hole, or 3M Mechanical Shearbolt Connector QCI Series, refer to the Instructions that are packed with the Shearbolt product for the Insulation Cutback length for the specific Shearbolt Lug or Connector being used. Table 6 can be used to assist in calculating the total Jacket Removal Length when using 3M Shearbolt Lugs QL2 Series: Two Hole, or 3M Shearbolt Connector QCI Series.

| Jacket Removal Calculation Table - Tape Shield Cable - 3M™ Mechanical Shearbolt QL2 Series Lugs / 3M™ Mechanical Shearbolt Connectors QCI Series - 7686-S-8 | | | |
|---|---------------------------------------|---------------------------------------|---|
| CABLE PREPARATION ITEM | Inches -Add this column- | mm -Add this column- | NOTES |
| Insulation Length | See NOTES Column for this Value | See NOTES Column for this Value | Refer to Table 4; • If using the 13.5" (342,9 mm) Semi- con cutback, enter 16.5" (419,1 mm) in the Insulation Length box. • If using the 13.0" (330,2 mm) Semi- con cutback, enter 16.0" (342,9 mm) in the Insulation Length box. |
| Insulation Removal Length= Depth of 3M™ Mechanical Shearbolt QL2 Series Lugs: Two Hole Barrel or 3M™ Mechanical Shearbolt Connectors QCI Series Barrel (See NOTES column.) | + | + | Obtain Insulation Removal Length: For Mechanical Shearbolt Lugs see 3M™ Mechanical Shearbolt Lugs QL2 Series: Two Hole Instructions. For Mechanical Shearbolt Connectors see 3M™ Mechanical Shearbolt Connectors QCI Series Instructions. |
| TOTAL JACKET REMOVAL LENGTH | = | = | |

Table 6

3.0 Install Ground Braid

3.1 Select a Scotch® Mastic Strip 2230 from kit and remove white release liners. Using light tension, apply a **SINGLE WRAP** of mastic around the cable jacket 1/4" (6 mm) from cut edge (Figure 2). Cut off excess.

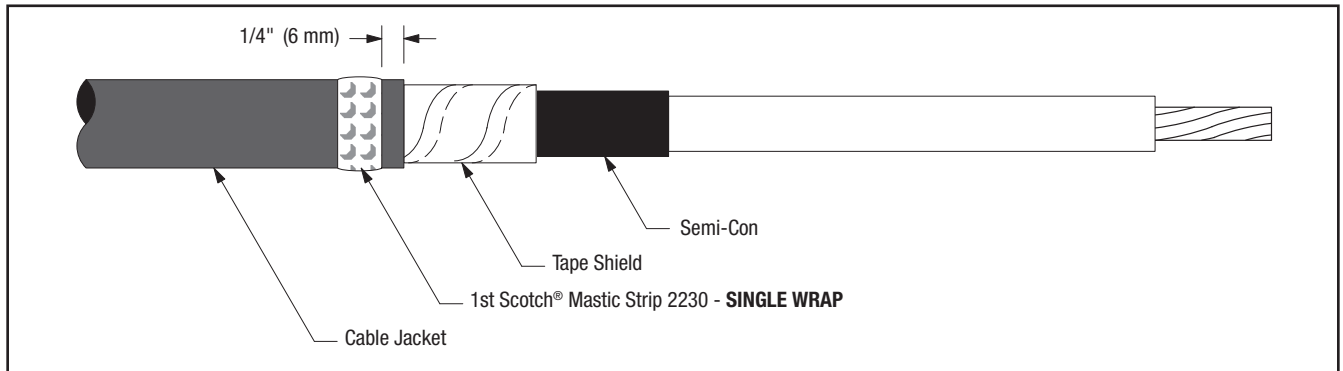

Figure 2

3.2 Position pre-formed ground braid with short tail over tape shield directly adjacent to cable jacket cut edge. PLEASE NOTE: The ground braid needs to make full contact with the metallic tape shield. Position long tail of ground braid, extending over cable jacket with solder block over mastic strip (Figure 3). Secure ground braid to cable jacket **4-1/2" (114 mm)** from cable semi-con edge using vinyl tape (see NOTE and Figure 3).

NOTE: Position vinyl tape with care, it also serves as a marker for positioning the termination.

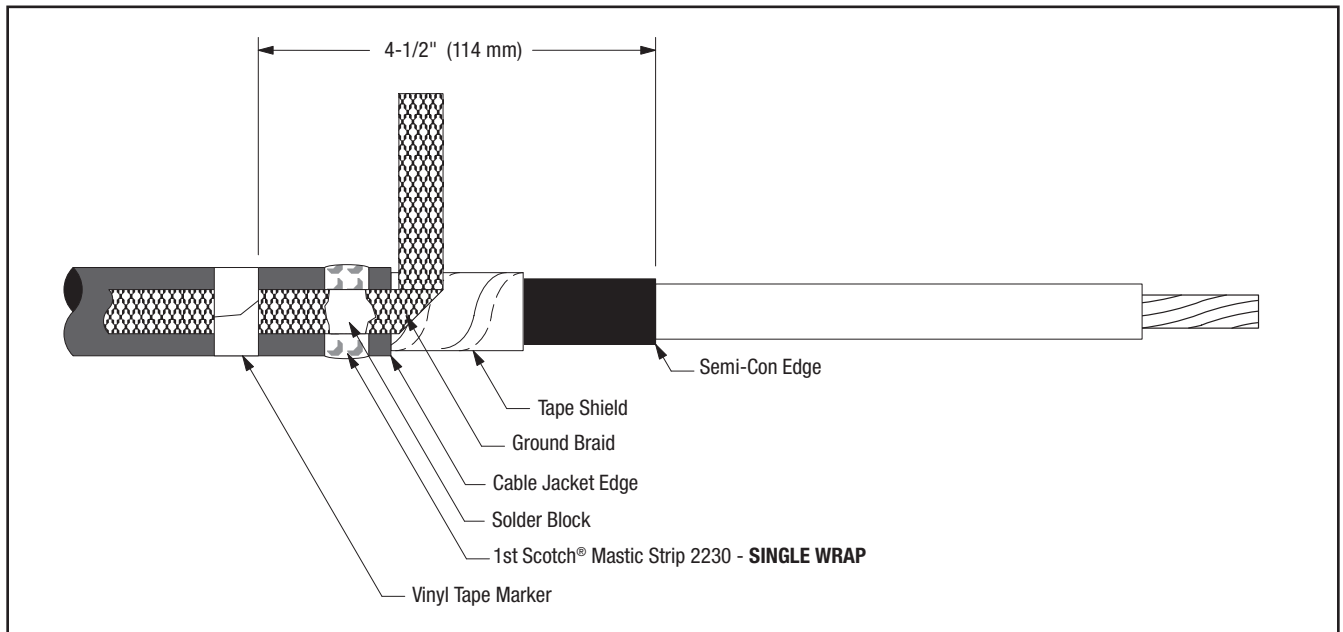

Figure 3

3.3 Wrap ground braid around cable tape shield one complete wrap, trim excess at approximately a 45 degree angle, and line up with the pre-bent 45 degree angle already on the ground braid, to prevent overlap. Secure in place with constant force spring. Wrap spring in same direction as ground braid (Figure 4). Cinch (tighten) the spring after wrapping the final winding.

3.4 Select second Scotch® Mastic Strip 2230 from kit and remove white release liners. Apply a second **SINGLE WRAP** of mastic over solder block on ground braid and previously applied mastic (Figure 4). Cut off excess.

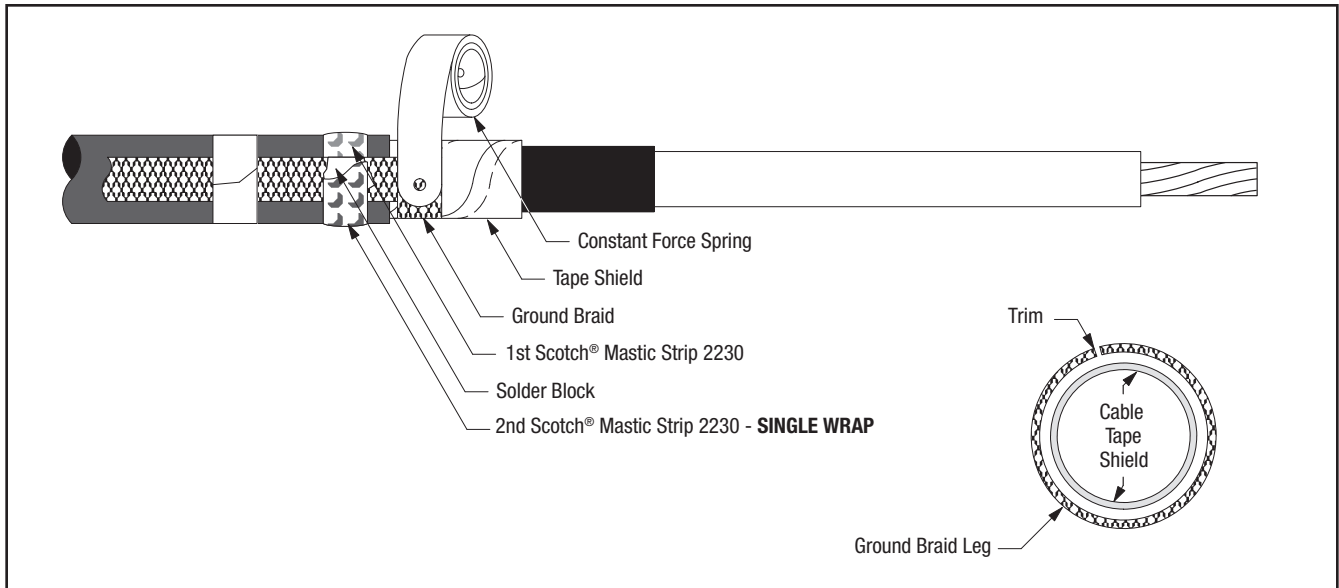

Figure 4

3.5 Wrap two highly stretched half-lapped layers of electrical grade vinyl tape around Scotch® Mastic Strip 2230, constant force spring and exposed tape shield (Figure 5).

NOTE: Take care not to cover exposed semi-con insulation shield. A minimum of 1" (25 mm) must be exposed.

NOTE: DO NOT completely cover the ground braid with electrical grade vinyl tape when applying over the Scotch® Mastic Strip 2230 per Step 3.5. LEAVE AT LEAST 1" (25 MM) OF EXPOSED GROUND BRAID between the Vinyl Tape Marker applied in step 3.2 and the start of the two half-lapped layers of electrical grade vinyl tape covering the Scotch® Mastic Strip 2230 applied in Step 3.5.

SPECIAL NOTE FOR CLOTH OR PAPER SEMI-CON INSULATION SHIELD

In cables with cloth or paper semi-conductive shields, it is recommended the shield be over wrapped with one half-lapped layer of highly stretched semi-conductive rubber tape, such as Scotch® Electrical Semi-Conducting Tape 13.

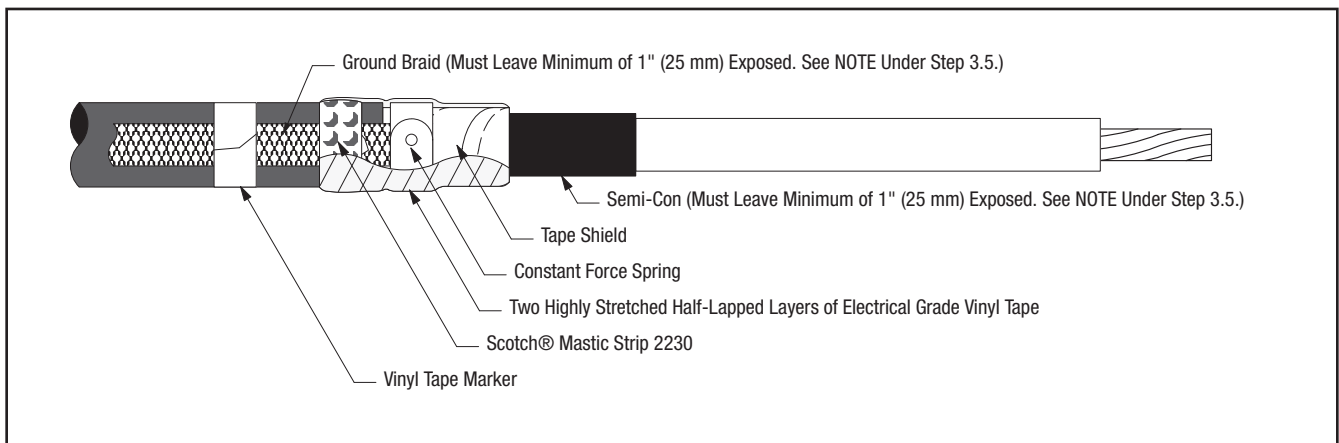

Figure 5

4.0 Install Lug or Connector

Important Packaging Notice

In order to make sure that you receive an undamaged termination, this 3M Cold Shrink QT-III Silicone Rubber Termination is packed with a RED SHIPPING CORE inside of the white core. Please remove the red shipping core BEFORE you install the termination. This shipping core can be recycled with other polypropylene waste.

- 4.1 Check to insure 3M Cold Shrink QT-III Silicone Rubber Termination assembly fits over the selected lug or connector BEFORE installing the lug or connector. If lug or connector. (Figure 6) will not fit through the termination core, clean the insulation (per Step 5.0) and slide termination on cable before installing lug or connector. **DO NOT REMOVE CORE AT THIS TIME.**

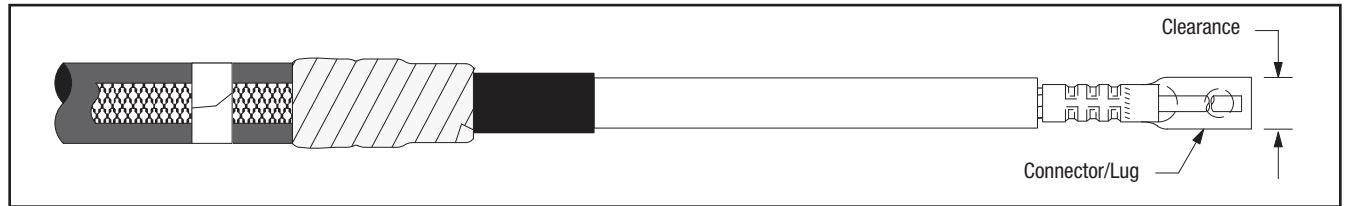

Figure 6

- 4.2 For 3M Compression Lugs and 3M Stem Connectors:
- Refer to pages 22-24 for 3M Connector and Lug crimping information.
 - For Aluminum Conductors - Thoroughly wire brush conductor strands to remove aluminum oxide layer. Insert conductor into lug or connector and then remove conductor. This will transfer some of the antioxidant paste onto the conductor. Wire brush the antioxidant paste into the strands. Immediately insert conductor into lug or connector barrel as far as it will go.

NOTE: Die/crimper head rotation between consecutive crimps is RECOMMENDED.

- Position connector or lug and crimp according to manufacturer's directions. Remove excess oxide inhibitor and sharp crimp flashings following crimping.
- 4.3 For 3M Mechanical Shearbolt Lugs QL2 Series: Two Hole or 3M Mechanical Shearbolt Connector QCI Series:
- Refer to the Instructions that are packed with the Shearbolt product for the installation procedures.

5.0 Clean Cable Insulation and Lug or Connector Barrel Using Standard Practice

- 5.1 If abrasive must be used:
- Use on insulation only. **DO NOT USE ABRASIVE ON SEMI-CON INSULATION SHIELD!**
 - Use only aluminum oxide abrasive; grit 120 or finer, included in 3M Cable Cleaning Preparation Kit CC-2.
 - Be careful not to reduce the cable insulation diameter below that allowed by the kit.
- 5.2 Wipe the cable insulation with one of the solvent saturated pads from the 3M Cable Cleaning Preparation Kit CC-2 **AND ALLOW IT TO DRY BEFORE INSTALLING TERMINATION. DO NOT ALLOW SOLVENT TO TOUCH SEMI-CON INSULATION SHIELD!**

6.0 Install Termination

- 6.1 Slide the termination body onto the cable and remove core. Make sure the termination body (not the core) is butted up to the edge of the vinyl tape marker previously applied in Step 3.2 (Figure 7). Pull the core while unwinding, counter-clockwise, starting with the loose end (Figure 7). Be sure to alternate the pulling and unwinding actions (pull-unwind-pull-unwind-etc.) to help prevent the core material from binding up as the core is being removed.

NOTE: Once the termination body makes contact over the mastic seal area, there is no need to continue supporting the assembly. DO NOT PUSH OR PULL ON THE TERMINATION ASSEMBLY WHILE UNWINDING THE CORE.

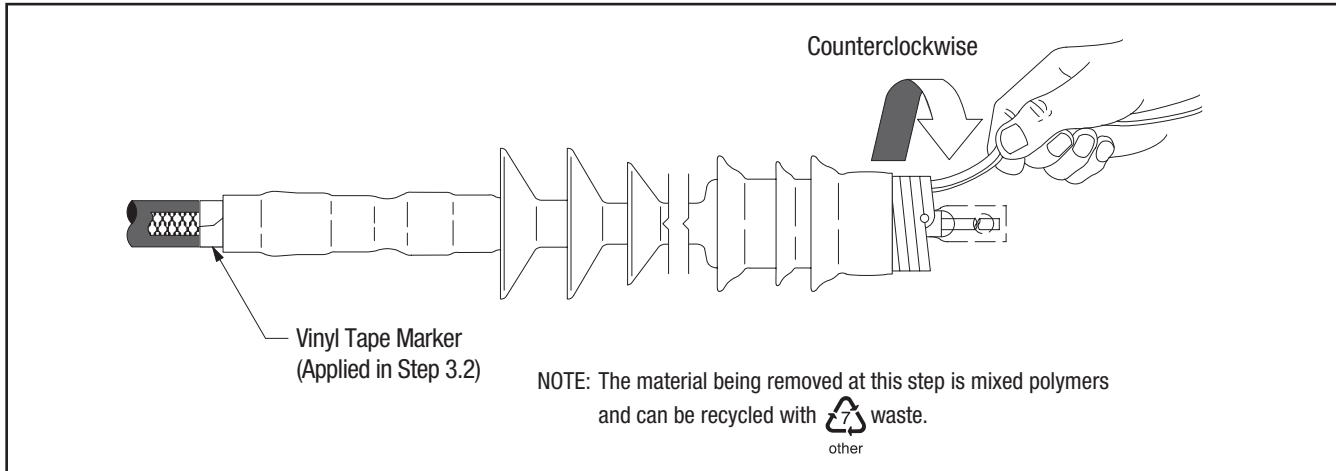
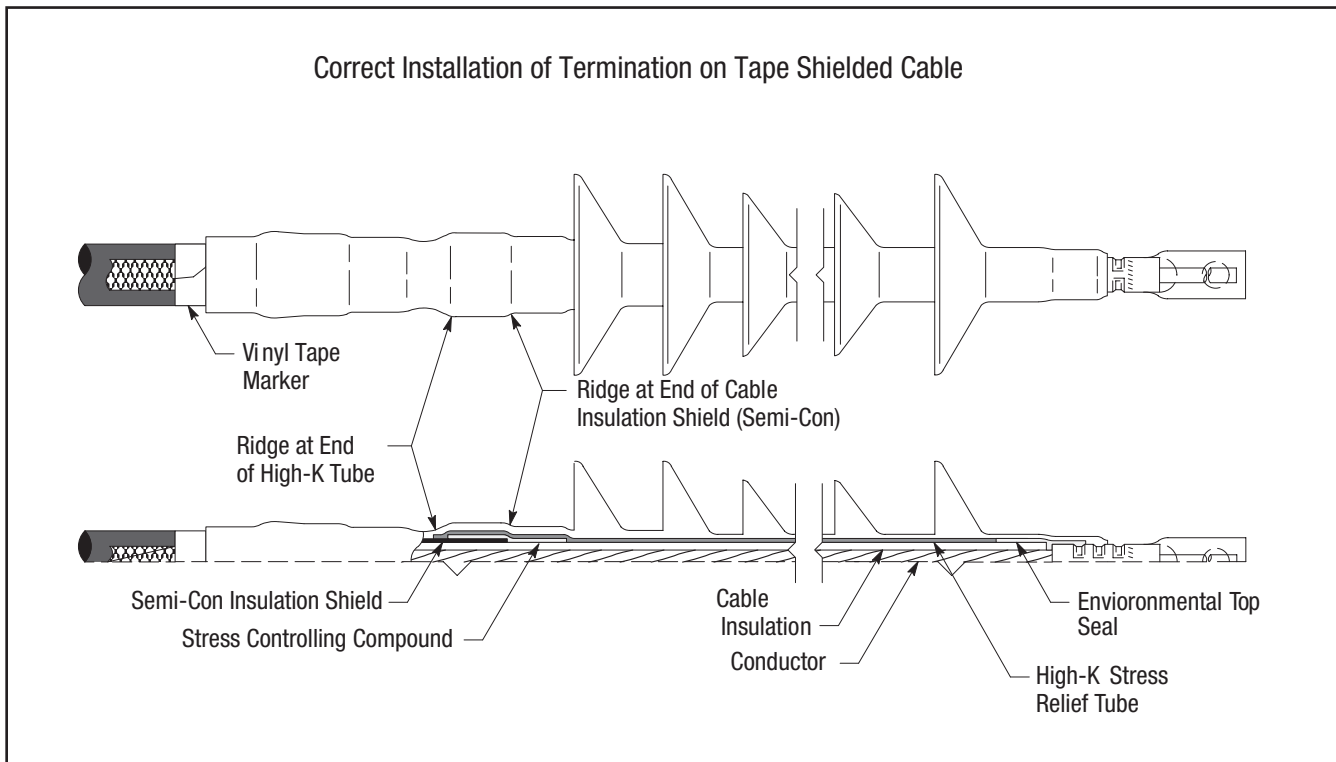

Figure 7

- 6.2 Connect ground braid to system ground according to standard practice.



Instructions for Wire Shielded Cable

7.0 Prepare Cable

- 7.1 Check to be sure cable size fits within kit range as shown in Table 1. (For Use With Compression Lugs or Connectors), or Table 2 (For Use With 3M Mechanical Shearbolt Lugs QL2 Series: Two Hole). Refer to Table 8 for semi-con cutback dimension.
- 7.2 Prepare cable using dimensions shown in Figure 8 and Figure 9. **BE SURE TO ALLOW FOR DEPTH OF TERMINAL LUG OR CONNECTOR**
- 7.3 If using 3M Shearbolt Lugs QL2 Series: Two Hole, or 3M Mechanical Shearbolt Connector QCI Series, proceed to Step 7.4. If using a Crimp Type (Compression) lug, measure the depth of the barrel. If using a Crimp Type (Compression) connector, measure to the barrel center stop/midpoint, and see the NOTE below in order to calculate the Insulation Removal Length. Table 9 can be used to assist in calculating the total Jacket Removal Length when using a compression lug or connector.

NOTE: Provide additional exposed conductor distance to account for growth during crimping of ALUMINUM lugs or connectors as follows:

| Aluminum Lug and Connector Growth Allowance | 2 - 350 1/4" (6 mm) | 400 - 650 1/2" (13 mm) | 750-1000 3/4" (19 mm) | 1250 - 2000 Field determined |
|---|------------------------|---------------------------|--------------------------|---------------------------------|
|---|------------------------|---------------------------|--------------------------|---------------------------------|

Table 7

NOTE: It is imperative to remove all remnants of the semi-con layer, even if the semi-con layer comes off as one layer. There should not be any remaining black areas, or particles, on the cable insulation layer.

| Kit Numbers | Insulation O.D. | 15 kV AWG / kcmil | 25/28 kV AWG / kcmil | 35 kV AWG / kcmil | Semi-con Cutback |
|-----------------|-----------------------------------|--|---|---|---------------------|
| 7686-S-8 | 1.53" – 1.85" (38,9 – 47,0 mm) | 1250 (625 mm ²) | 900 – 1000 (500 mm ²) | 700 – 900 (400 mm ²) | 13.5" (342,9 mm) |
| | 1.65" – 2.32" (42,0 – 58,9 mm) | 1500 – 2000 (630 – 1000 mm ²) | 1250 – 1750 (625 – 800 mm ²) | 1000 – 1500 (500 – 725 mm ²) | 13.0" (330,2 mm) |

Table 8

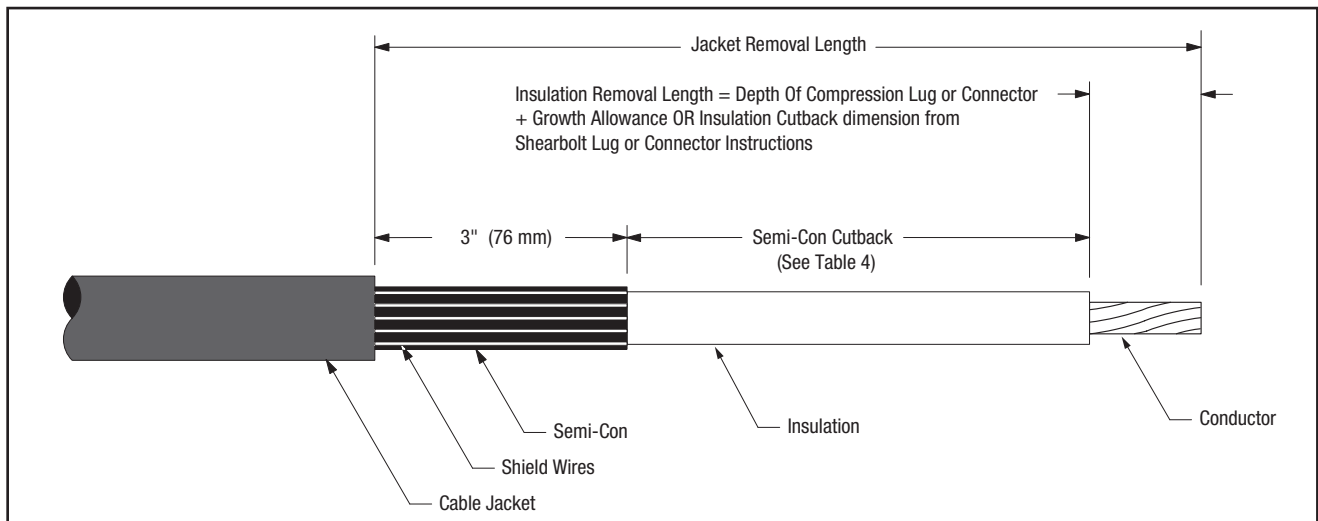

Figure 8

3M™ Cold Shrink QT-III Silicone Rubber Skirted Termination Kit With High-K Stress Relief

| Jacket Removal Calculation Table - Wire Shield Cable - Crimp Type (Compression) Lugs / Connectors - 7686-S-8 | | | |
|---|---------------------------------|---------------------------------|---|
| CABLE PREPARATION ITEM | Inches -Add this column- | mm -Add this column- | NOTES |
| Insulation Length | See NOTES Column for this Value | See NOTES Column for this Value | Refer to Table 8; • If using the 13.5" (342,9 mm) Semi-con cutback, enter 16.5" (419,1 mm) in the Insulation Length box. • If using the 13.0" (330,2 mm) Semi-con cutback, enter 16.0" (342,9 mm) in the Insulation Length box. |
| Insulation Removal Length = Depth of Crimp Type (Compression) Terminal Lug or Connector Barrel (See NOTES column.) | + | + | Measure full depth of bore for lugs and to the center stop for connectors. |
| Growth Allowance (Aluminum Only) for Crimp Type (Compression) Lug / Connector (See NOTES column.) | + | + | See Table 7 for correct growth allowance. This measurement applies only to Aluminum lugs / connectors. |
| TOTAL JACKET REMOVAL LENGTH | = | = | |

Table 9

7.4 If using 3M Mechanical Shearbolt Lugs QL2 Series: Two Hole, or 3M Mechanical Shearbolt Connector QCI Series, refer to the Instructions that are packed with the Shearbolt product for the Insulation Cutback length for the specific Shearbolt Lug or Connector being used. Table 10 can be used to assist in calculating the total Jacket Removal Length when using 3M Shearbolt Lugs QL2 Series: Two Hole, or 3M Shearbolt Connector QCI Series.

| Jacket Removal Calculation Table - Wire Shield Cable - 3M™ Mechanical Shearbolt QL2 Series Lugs / 3M™ Mechanical Shearbolt Connectors QCI Series - 7686-S-8 | | | |
|--|---------------------------------|---------------------------------|---|
| CABLE PREPARATION ITEM | Inches -Add this column- | mm -Add this column- | NOTES |
| Insulation Length | See NOTES Column for this Value | See NOTES Column for this Value | Refer to Table 8; • If using the 13.5" (342,9 mm) Semi-con cutback, enter 16.5" (419,1 mm) in the Insulation Length box. • If using the 13.0" (330,2 mm) Semi-con cutback, enter 16.0" (342,9 mm) in the Insulation Length box. |
| Insulation Removal Length= Depth of 3M™ Mechanical Shearbolt QL2 Series Lugs: Two Hole Barrel or 3M™ Mechanical Shearbolt Connectors QCI Series Barrel (See NOTES column.) | + | + | Obtain Insulation Removal Length: For Mechanical Shearbolt Lugs see 3M™ Mechanical Shearbolt Lugs QL2 Series: Two Hole Instructions. For Mechanical Shearbolt Connectors see 3M™ Mechanical Shearbolt Connectors QCI Series Instructions. |
| TOTAL JACKET REMOVAL LENGTH | = | = | |

Table 10

3M™ Cold Shrink QT-III Silicone Rubber Skirted Termination Kit With High-K Stress Relief

7.5 Bend leading 1-1/2" (38 mm) of exposed shield wires back upon themselves to jacket edge (Figure 9).

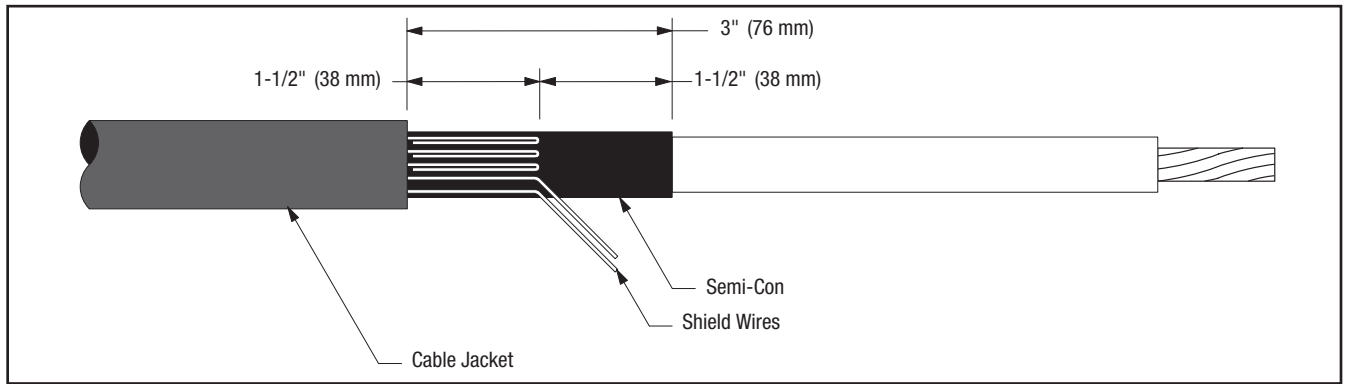

Figure 9

8.0 Install Ground Braid

8.1 Select a Scotch® Mastic Strip 2230 from kit and remove white release liners. Using light tension apply a **SINGLE WRAP** of mastic around the cable jacket 1/4" (6 mm) from cut edge (Figure 10). Cut off excess.

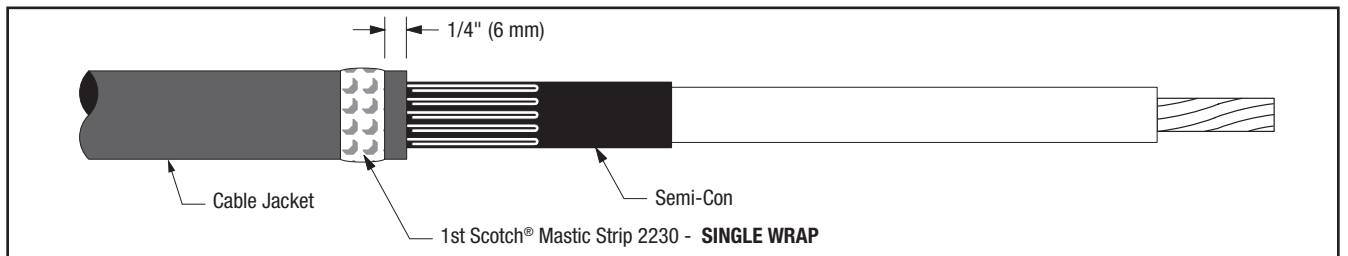

Figure 10

8.2 Position pre-formed ground braid with short tail over wire shield directly adjacent to cable jacket cut edge. PLEASE NOTE: The ground braid needs to make full contact with the shield wires. Position long tail of ground braid, extending over cable jacket with solder block over mastic strip (Figure 11). Secure ground braid to cable jacket 4-1/2" (114 mm) from cable semi-con edge using vinyl tape (see NOTE and Figure 11).

NOTE: Position vinyl tape with care, it also serves as a marker for positioning the termination.

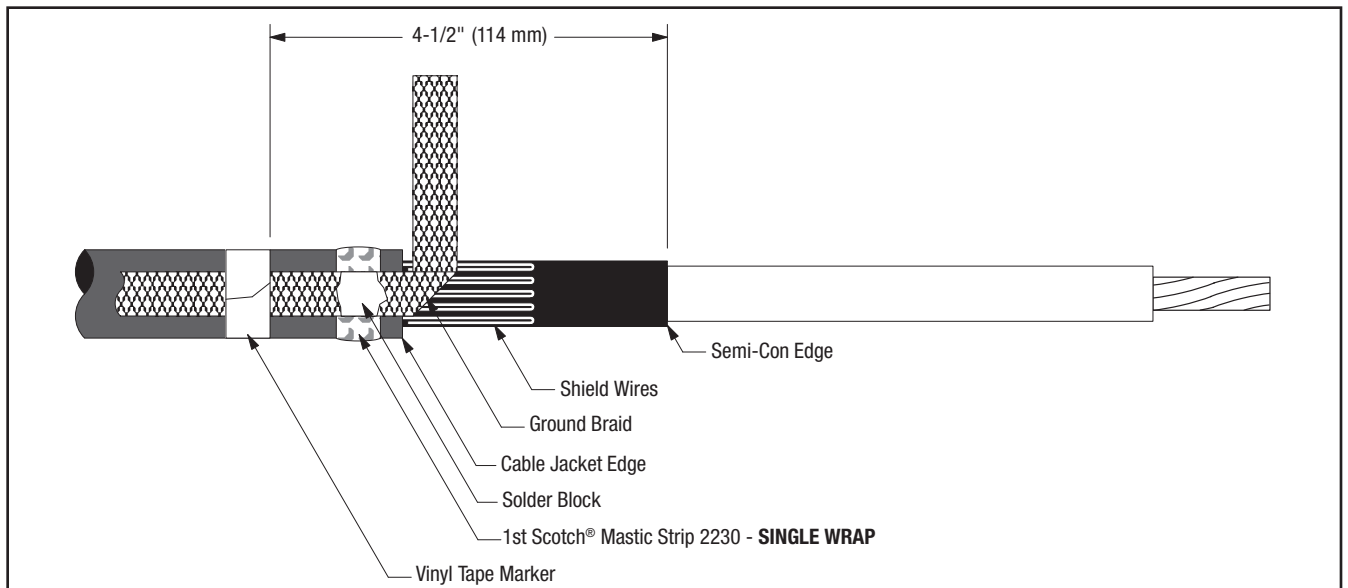

Figure 11

3M™ Cold Shrink QT-III Silicone Rubber Skirted Termination Kit With High-K Stress Relief

- 8.3 Wrap ground braid around cable shield wires one complete wrap, trim excess at approximately a 45 degree angle, and line up with the pre-bent 45 degree angle already on the ground braid, to prevent overlap. Secure in place with constant force spring. Wrap spring in same direction as ground braid (Figure 12). Cinch (tighten) the spring after wrapping the final winding.
- 8.4 Select second Scotch® Mastic Strip 2230 from kit and remove white release liners. Apply a second **SINGLE WRAP** of mastic over solder block on ground braid and previously applied mastic (Figure 12). Cut off excess.

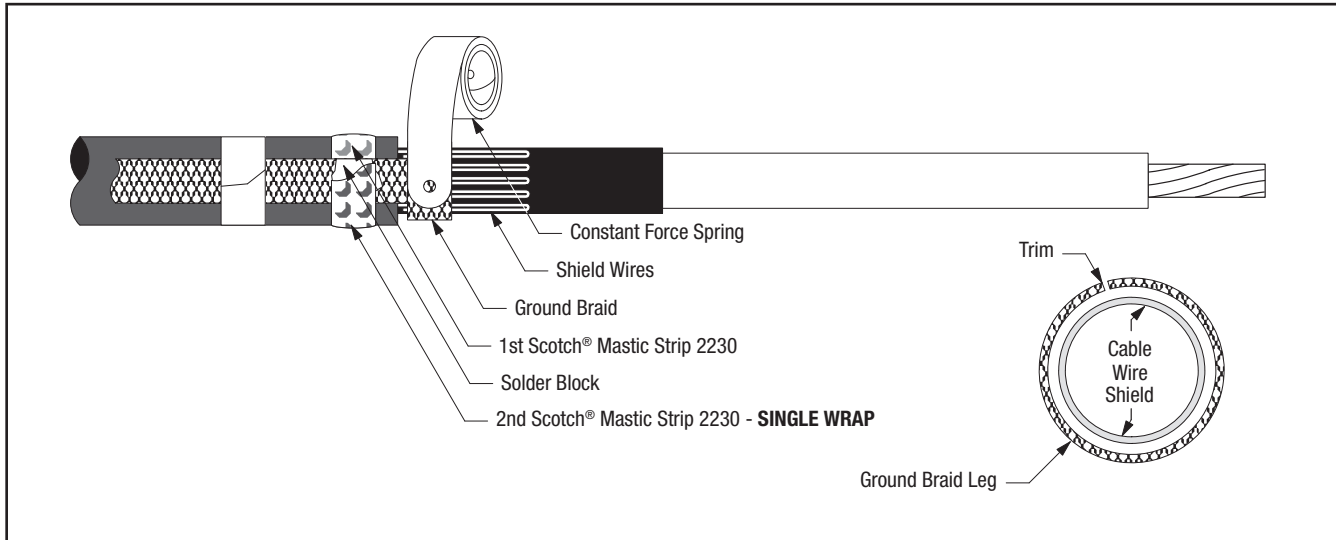

Figure 12

- 8.5 Wrap two highly stretched half-lapped layers of electrical grade vinyl tape around mastic seal, constant force spring and exposed shield wires (Figure 13).

NOTE: Take care not to cover exposed semi-con insulation shield. A minimum of 1" (25 mm) must be exposed.

NOTE: DO NOT completely cover the ground braid with electrical grade vinyl tape when applying over the Scotch® Mastic Strip 2230 per Step 8.5. LEAVE AT LEAST 1" (25 MM) OF EXPOSED GROUND BRAID between the Vinyl Tape Marker applied in step 8.2 and the start of the two half-lapped layers of electrical grade vinyl tape covering the Scotch® Mastic Strip 2230 applied in Step 8.5.

SPECIAL NOTE FOR CLOTH OR PAPER SEMI-CON INSULATION SHIELD

In cables with cloth or paper semi-conductive shields, it is recommended the shield be over-wrapped with one half-lapped layer of highly stretched semi-conductive rubber tape, such as Scotch® Electrical Semi-Conducting Tape 13.

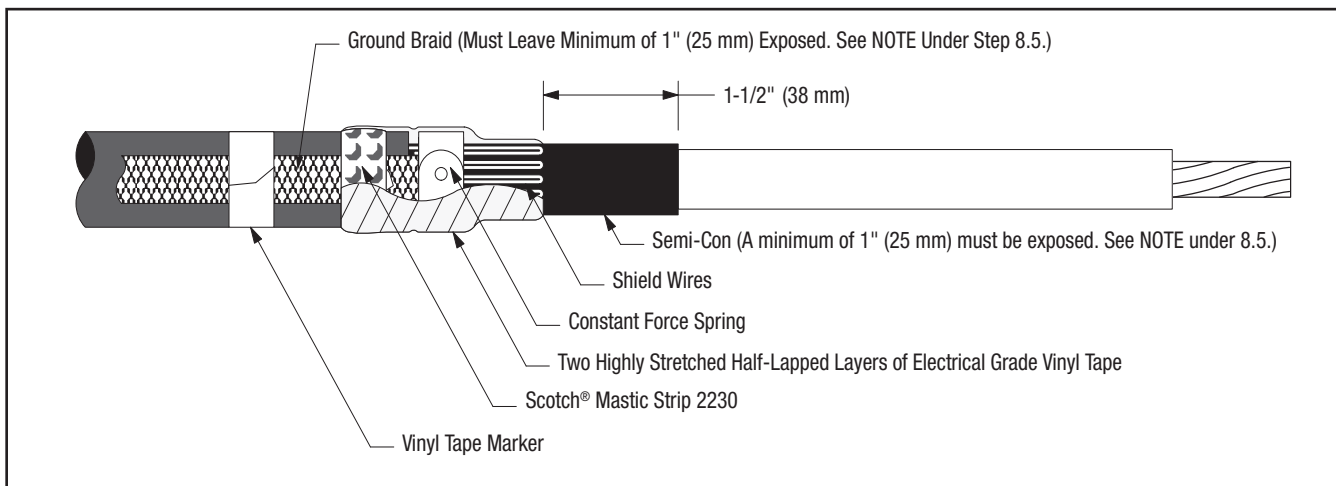

Figure 13

9.0 Install Lug or Connector

Important Packaging Notice

In order to make sure that you receive an undamaged termination, this 3M Cold Shrink QT-III Silicone Rubber Termination is packed with a RED SHIPPING CORE inside of the white core. Please remove the red shipping core BEFORE you install the termination. This shipping core can be recycled with other polypropylene waste.

- 9.1 Check to insure 3M Cold Shrink QT-III Silicone Rubber Termination assembly fits over the selected lug or connector BEFORE installing the lug or connector. If lug or connector (Figure 14) will not fit through the termination core, clean the insulation (per Step 10.0) and slide termination on cable before installing lug. **DO NOT REMOVE CORE AT THIS TIME.**

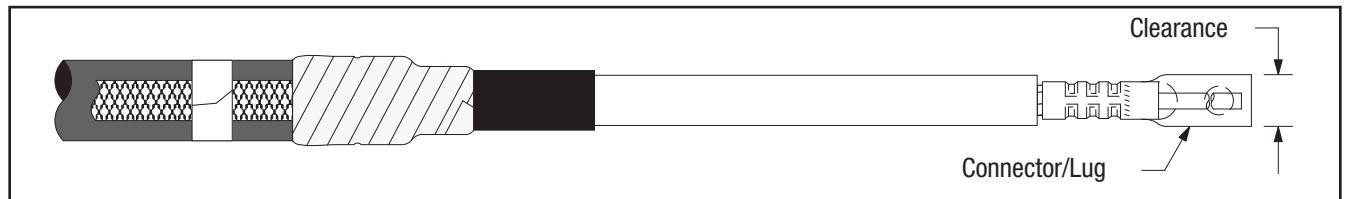

Figure 14

- 9.2 For 3M Compression Lugs and 3M Stem Connectors:
- Refer to pages 22-24 for 3M Connector and Lug crimping information.
 - For Aluminum Conductors - Thoroughly wire brush conductor strands to remove aluminum oxide layer. Insert conductor into lug or connector and then remove conductor. This will transfer some of the antioxidant paste onto the conductor. Wire brush the antioxidant paste into the strands. Immediately insert conductor into lug or connector barrel as far as it will go.

NOTE: Die/crimper head rotation between consecutive crimps is RECOMMENDED.

- Position connector or lug and crimp according to manufacturer's directions. Remove excess oxide inhibitor and sharp crimp flashings following crimping.
- 9.3 For 3M Mechanical Shearbolt Lugs QL2 Series: Two Hole or 3M Mechanical Shearbolt Connector QCI Series:
- Refer to the Instructions that are packed with the Shearbolt product for the installation procedures.

10.0 Clean Cable Insulation and Lug or Connector Barrel Using Standard Practice

- 10.1 If abrasive must be used:
- Use on insulation only. **DO NOT USE ABRASIVE ON SEMI-CON INSULATION SHIELD!**
 - Use only aluminum oxide abrasive; grit 120 or finer, included in the 3M Cable Cleaning Preparation Kit CC-2.
 - Be careful not to reduce the cable insulation diameter below that allowed by the kit.
- 10.2 Wipe the cable insulation with one of the solvent saturated pads from the 3M Cable Cleaning Preparation Kit CC-2 **AND ALLOW IT TO DRY BEFORE INSTALLING TERMINATION. DO NOT ALLOW SOLVENT TO TOUCH SEMI-CON INSULATION SHIELD!**

11.0 Install Termination

11.1 Slide the termination body onto the cable and remove core. Make sure the termination body (not the core) is butted up to the edge of the vinyl tape marker previously applied in Step 8.2 (Figure 15). Pull the core while unwinding, counter-clockwise, starting with the loose end (Figure 15). Be sure to alternate the pulling and unwinding actions (pull-unwind-pull-unwind-etc.) to help prevent the core material from binding up as the core is being removed.

NOTE: Once the termination body makes contact over the mastic seal area, there is no need to continue supporting the assembly. DO NOT PUSH OR PULL ON THE TERMINATION ASSEMBLY WHILE UNWINDING THE CORE.

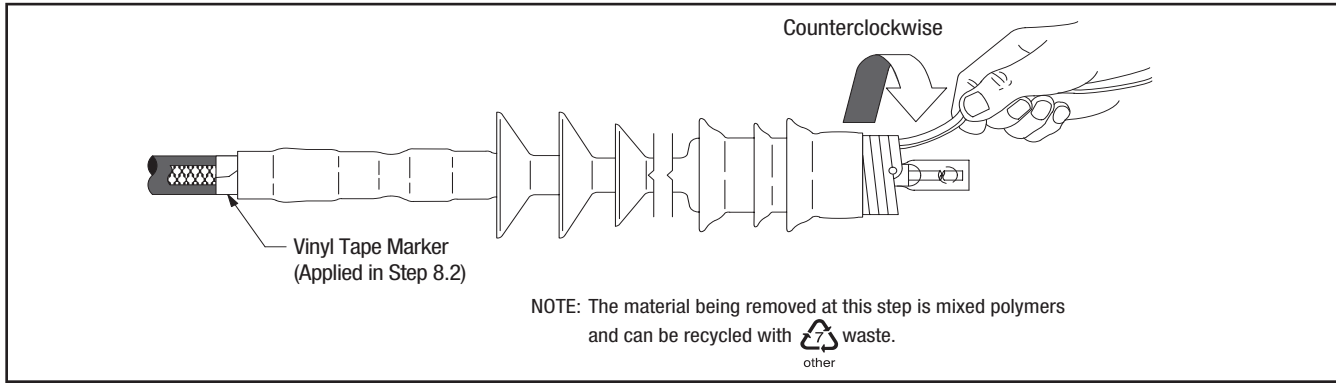
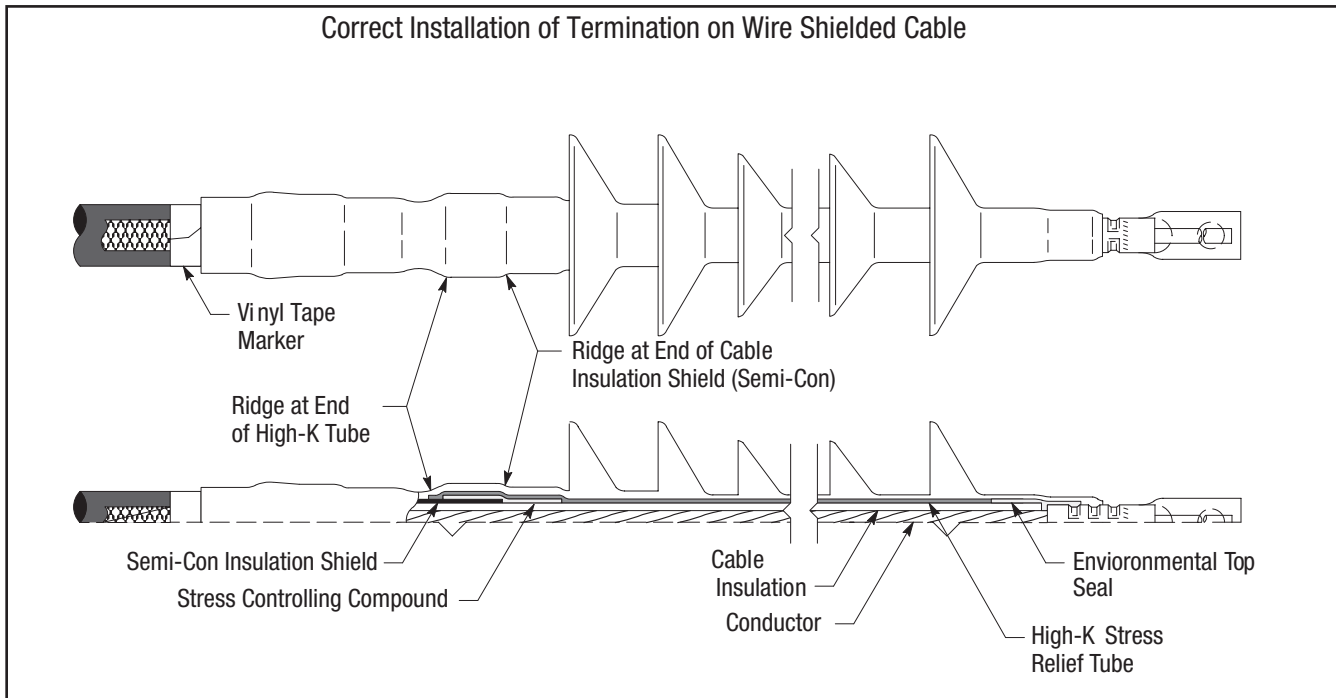

Figure 15

11.2 Connect ground braid to system ground according to standard practice.



Instructions for UniShield® Cable

12.0 Prepare Cable

12.1 Check to be sure cable size fits within kit range as shown in Table 1 (For Use With Compression Lugs or Connectors), or Table 2 (For Use With 3M Mechanical Shearbolt Lugs QL2 Series: Two Hole). Refer to Table 12 for Semi-Conductive Jacket cutback dimension [A].

12.2 Prepare cable using dimensions shown in Figures 16, 17 and 18. **BE SURE TO ALLOW FOR DEPTH OF TERMINAL LUG OR CONNECTOR.**

3M™ Cold Shrink QT-III Silicone Rubber Skirted Termination Kit With High-K Stress Relief

- 12.3 If using 3M Mechanical Shearbolt Lugs QL2 Series: Two Hole, or 3M Mechanical Shearbolt Connector QCI Series, proceed to step 12.5. If using a Crimp Type (Compression) lug, measure the depth of the barrel, or if using a Crimp Type (Compression) connector, measure to the barrel center stop/midpoint, and see the NOTE below in order to calculate the Insulation Removal Length. Table 13 can be used to assist in calculating the total Semi-Conductive Jacket Removal Length when using a compression lug or connector.
- 12.4 Install constant force spring as shown in Figure 16. Pull shield wires through semi-conductive jacket to leading edge of constant force spring (Figure 16).

NOTE: Provide additional exposed conductor distance to account for growth during crimping of ALUMINUM lugs or connectors as follows:

| Aluminum Lug and Connector Growth Allowance | 2 - 350 1/4" (6 mm) | 400 - 650 1/2" (13 mm) | 750-1000 3/4" (19 mm) | 1250 - 2000 Field determined |
|---|------------------------|---------------------------|--------------------------|---------------------------------|
|---|------------------------|---------------------------|--------------------------|---------------------------------|

Table 11

| Kit Numbers | Insulation O.D. | 15 kV AWG / kcmil | 25/28 kV AWG / kcmil | 35 kV AWG / kcmil | Dimension [A] |
|-----------------|-----------------------------------|--|---|---|---------------------|
| 7686-S-8 | 1.53" – 1.85" (38,9 – 47,0 mm) | 1250 (625 mm ²) | 900 – 1000 (500 mm ²) | 700 – 900 (400 mm ²) | 13.5" (342,9 mm) |
| | 1.65" – 2.32" (42,0 – 58,9 mm) | 1500 – 2000 (630 – 1000 mm ²) | 1250 – 1750 (625 – 800 mm ²) | 1000 – 1500 (500 – 725 mm ²) | 13.0" (330,2 mm) |

Table 12

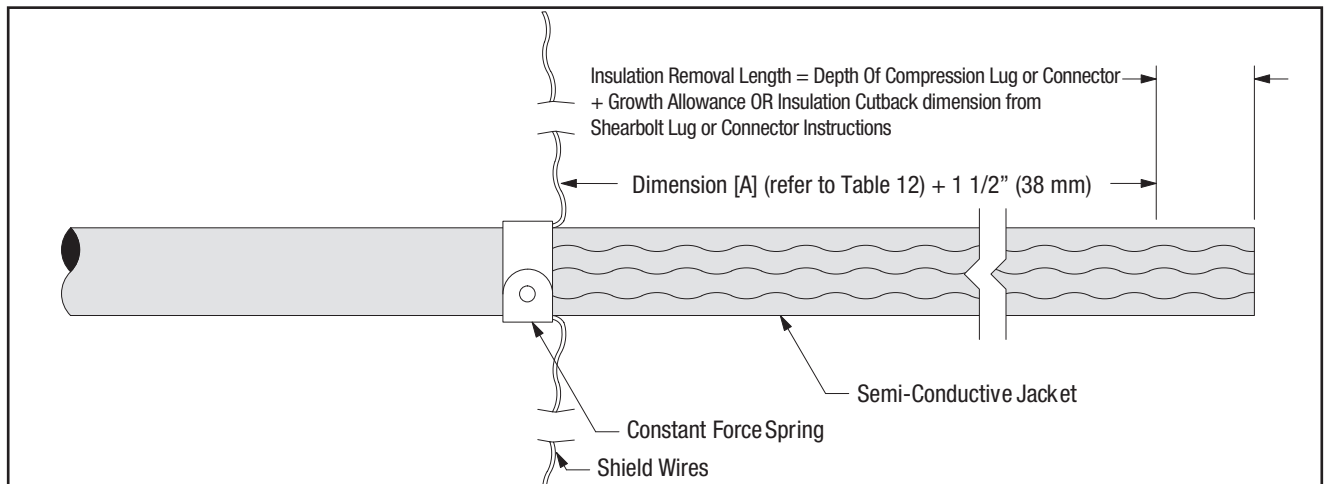

Figure 16

3M™ Cold Shrink QT-III Silicone Rubber Skirted Termination Kit With High-K Stress Relief

| Semi-Conductive Jacket Preparation Calculation Table - UniShield® Cable - Crimp Type (Compression) Lugs / Connectors - 7686-S-8 | | | |
|---|---------------------------------------|---------------------------------------|--|
| CABLE PREPARATION ITEM | Inches -Add this column- | mm -Add this column- | NOTES |
| Semi-Conductive Jacket Length | See NOTES Column for this Value | See NOTES Column for this Value | Refer to Table 12; • If using the 13.5" (342,9 mm) Jacket cutback, enter 16.5" (419,1 mm) in the Jacket Length box. • If using the 13.0" (330,2 mm) Jacket cutback, enter 16.0" (342,9 mm) in the Jacket Length box. |
| Additional Semi-Conductive Jacket Length | + 1.5" | + 38 mm | Value from figure 16 |
| Insulation Removal Length = Depth of Crimp Type (Compression) Terminal Lug or Connector Barrel (See NOTES column.) | + | + | Measure full depth of bore for lugs and to the center stop for connectors. |
| Growth Allowance (Aluminum Only) for Crimp Type (Compression) Lug / Connector (See NOTES column.) | + | + | See Table 11 for correct growth allowance. This measurement applies only to Aluminum lugs / connectors. |
| TOTAL JACKET REMOVAL LENGTH | = | = | |

Table 13

12.5 If using 3M Mechanical Shearbolt Lugs QL2 Series: Two Hole, or 3M Mechanical Shearbolt Connector QCI Series, refer to the Instructions that are packed with the Shearbolt product for the Insulation Cutback length for the specific Shearbolt Lug or Connector being used. Table 14 can be used to assist in calculating the total Semi-Conductive Jacket Removal Length when using 3M Shearbolt Lugs QL2 Series: Two Hole, or 3M Shearbolt Connector QCI Series.

| Semi-Conductive Jacket Preparation Calculation Table - UniShield® Cable- 3M™ Mechanical Shearbolt QL2 Series Lugs / 3M™ Mechanical Shearbolt Connectors QCI Series - 7686-S-8 | | | |
|---|---------------------------------------|---------------------------------------|---|
| CABLE PREPARATION ITEM | Inches -Add this column- | mm -Add this column- | NOTES |
| Semi-Conductive Jacket Length | See NOTES Column for this Value | See NOTES Column for this Value | Refer to Table 12; • If using the 13.5" (342,9 mm) Jacket cutback, enter 16.5" (419,1 mm) in the Jacket Length box. • If using the 13.0" (330,2 mm) Jacket cutback, enter 16.0" (342,9 mm) in the Jacket Length box.. |
| Additional Semi-Conductive Jacket Length | + 1.5" | + 38 mm | Value from figure 16 |
| Insulation Removal Length= Depth of 3M™ Mechanical Shearbolt QL2 Series Lugs: Two Hole Barrel or 3M™ Mechanical Shearbolt Connectors QCI Series Barrel (See NOTES column.) | + | + | Obtain Insulation Removal Length: For Mechanical Shearbolt Lugs see 3M™ Mechanical Shearbolt Lugs QL2 Series: Two Hole Instructions. For Mechanical Shearbolt Connectors see 3M™ Mechanical Shearbolt Connectors QCI Series Instructions. |
| TOTAL JACKET REMOVAL LENGTH | = | = | |

Table 14

3M™ Cold Shrink QT-III Silicone Rubber Skirted Termination Kit With High-K Stress Relief

12.6 Remove constant force spring. Bend shield wires back upon semi-conductive jacket 1-1/2" (38 mm). Cut excess shield wire and discard (Figure 17).

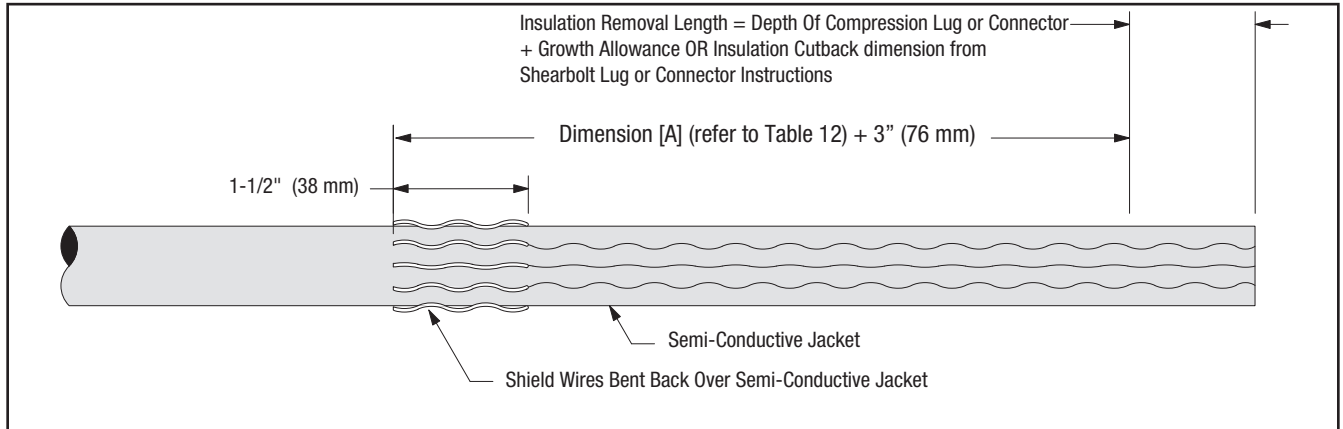

Figure 17

12.7 Remove semi-conductive jacket to dimension shown in Figure 18.

NOTE: To ease jacket removal, install constant force spring as shown in Figure 18 and ring-cut 80% through jacket. Remove jacket sections by pulling against constant force spring. DO NOT BELL SEMI-CON JACKET. Remove constant force spring.

NOTE: It is imperative to remove all remnants of the semi-conductive jacket, even if the semi-conductive jacket comes off as one layer. There should not be any remaining black areas, or particles, on the cable insulation layer.

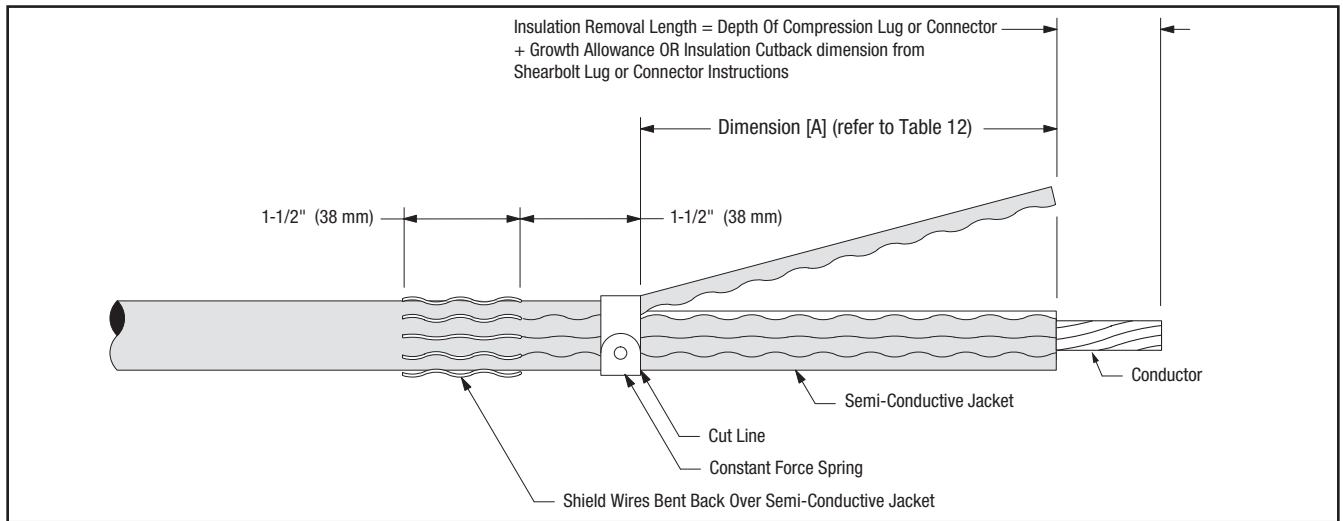

Figure 18

13.0 Install Ground Braid

13.1 Select a Scotch® Mastic Strip 2230 from kit and remove white release liners. Using light tension apply a **SINGLE WRAP** of mastic around the cable semi-conductive jacket 1/4" (6 mm) from shield wires (Figure 19). Cut off excess.

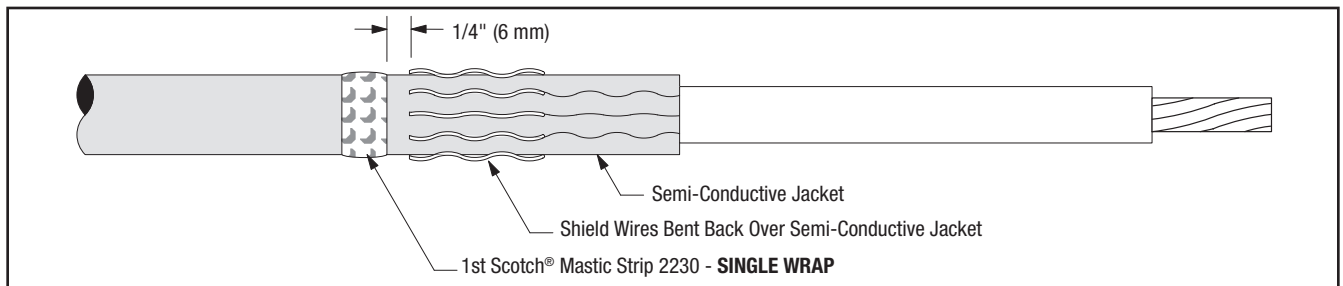

Figure 19

3M™ Cold Shrink QT-III Silicone Rubber Skirted Termination Kit With High-K Stress Relief

13.2 Position pre-formed ground braid with short tail directly over cut edge of folded back shield wires. PLEASE NOTE: The ground braid needs to make full contact with the shield wires. Position long tail of ground braid, extending over cable semi-conductive jacket with solder block over mastic strip (Figure 20). Secure ground braid to cable semi-conductive jacket 4-1/2" (114 mm) from cable Semi-Conductive Jacket edge using vinyl tape (See NOTE and Figure 20).

NOTE: Position vinyl tape with care, it also serves as a marker for positioning the termination.

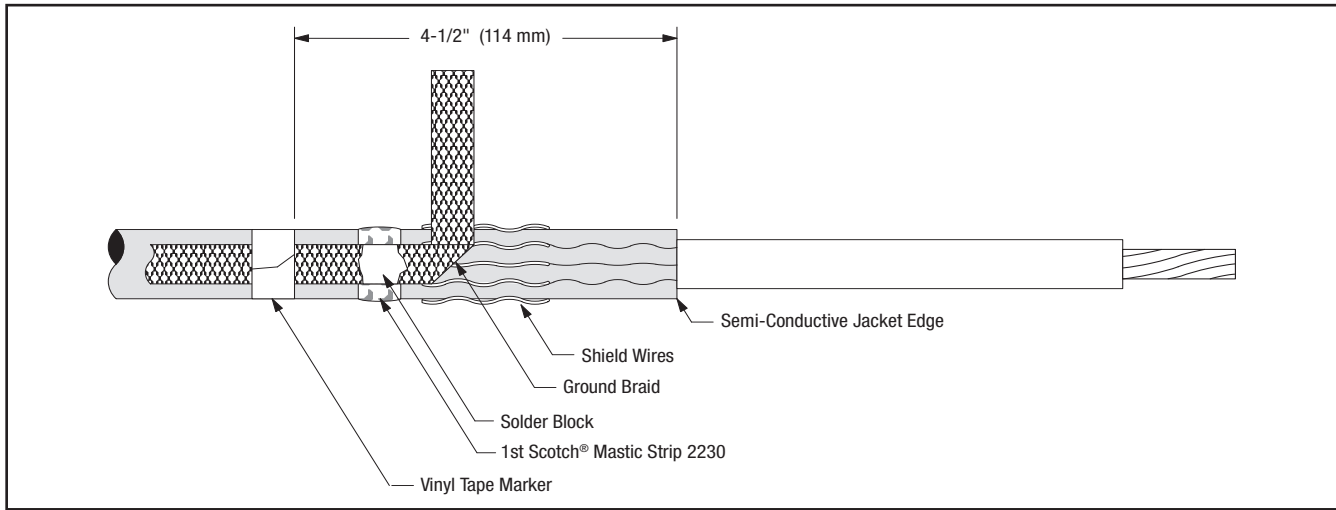

Figure 20

13.3 Wrap ground braid around cable shield wires one complete wrap, trim excess at approximately a 45 degree angle, and line up with the pre-bent 45 degree angle already on the ground braid, to prevent overlap. Secure in place with constant force spring. Wrap spring in same direction as ground braid (Figure 21). Cinch (tighten) the spring after wrapping the final winding.

13.4 Select second Scotch® Mastic Strip 2230 from kit and remove white release liners. Apply a second **SINGLE WRAP** of mastic over solder block on ground braid and previously applied mastic (Figure 21). Cut off excess.

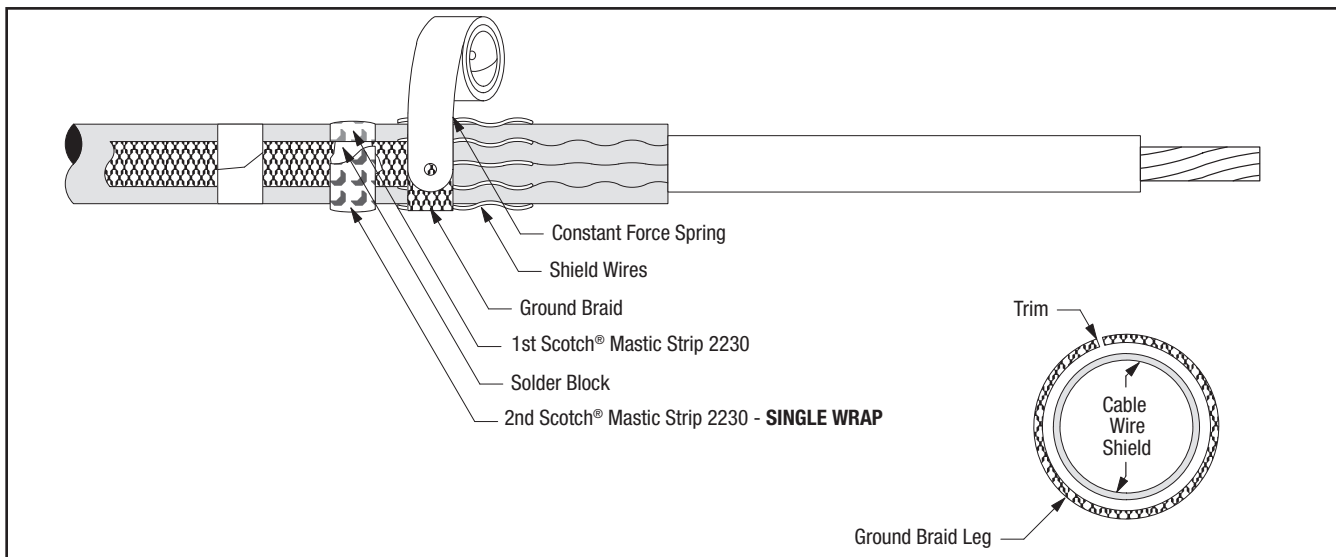

Figure 21

13.5 Wrap two highly stretched half-lapped layers of electrical grade vinyl tape around mastic seal, constant force spring and exposed shield wires (Figure 22).

3M™ Cold Shrink QT-III Silicone Rubber Skirted Termination Kit With High-K Stress Relief

NOTE: Take care not to cover exposed Semi-Conductive Jacket. A minimum of 1" (25 mm) must be exposed.

NOTE: DO NOT completely cover the ground braid with electrical grade vinyl tape when applying over the Scotch® Mastic Strip 2230 per Step 13.5. LEAVE AT LEAST 1" (25 MM) OF EXPOSED GROUND BRAID between the Vinyl Tape Marker applied in step 13.2 and the start of the two half-lapped layers of electrical grade vinyl tape covering the Scotch® Mastic Strip 2230 applied in Step 13.5.

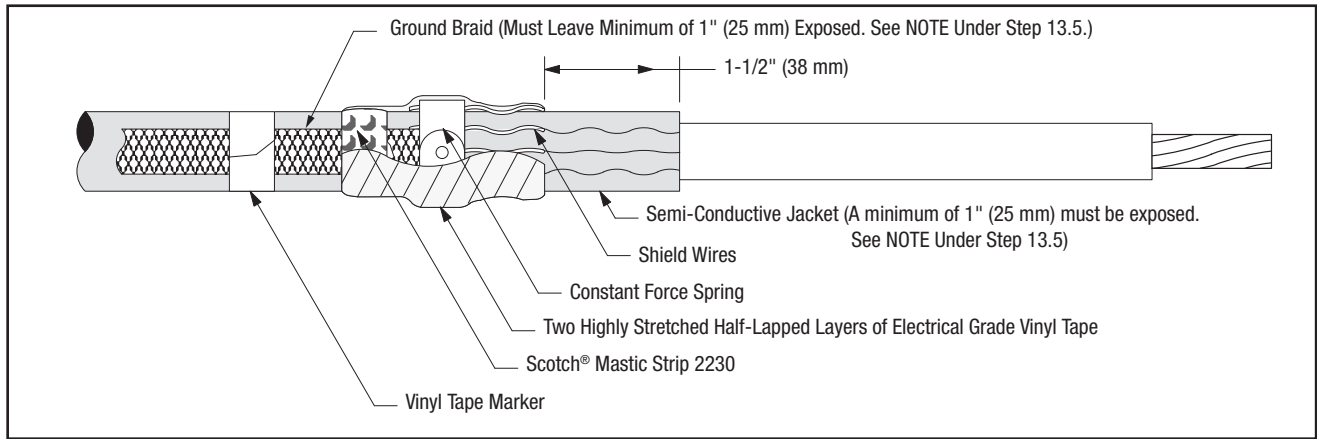

Figure 22

14.0 Install Lug or Connector

Important Packaging Notice

In order to make sure that you receive an undamaged termination, this 3M Cold Shrink QT-III Silicone Rubber Termination is packed with a RED SHIPPING CORE inside of the white core. Please remove the red shipping core BEFORE you install the termination. This shipping core can be recycled with other polypropylene waste.

14.1 Check to insure 3M Cold Shrink QT -III Silicone Rubber Termination fits over the selected lug or connector BEFORE installing the lug or connector. If lug or connector (Figure 23) will not fit through the termination core, clean the insulation (per Step 15.0) and slide termination on cable before installing lug or connector. **DO NOT REMOVE CORE AT THIS TIME.**

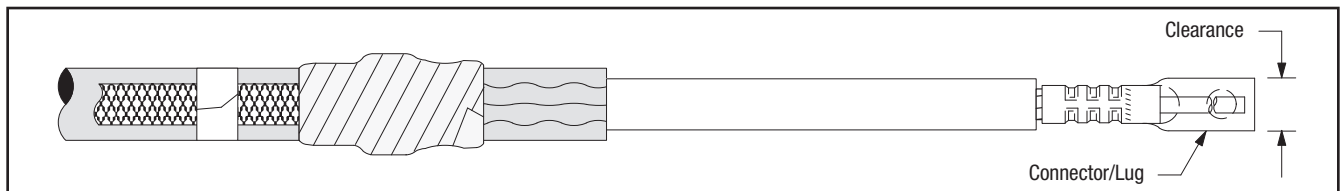

Figure 23

3M™ Cold Shrink QT-III Silicone Rubber Skirted Termination Kit With High-K Stress Relief

- 14.2 For 3M Compression Lugs and 3M Stem Connectors:
- Refer to pages 22-24 for 3M Connector and Lug crimping information.
 - For Aluminum Conductors - Thoroughly wire brush conductor strands to remove aluminum oxide layer. Insert conductor into lug or connector and then remove conductor. This will transfer some of the antioxidant paste onto the conductor. Wire brush the antioxidant paste into the strands. Immediately insert conductor into lug or connector barrel as far as it will go.

NOTE: Die/crimper head rotation between consecutive crimps is Recommended.

- Position connector or lug and crimp according to manufacturer's directions. Remove excess oxide inhibitor and sharp crimp flashings following crimping.
- 14.3 For 3M Mechanical Shearbolt Lugs QL2 Series: Two Hole or 3M Mechanical Shearbolt Connector QCI Series:
- Refer to the Instructions that are packed with the Shearbolt product for the installation procedures.

15.0 Clean Cable Insulation and Lug or Connector Barrel Using Standard Practice

- 15.1 If abrasive must be used:
- Use on insulation only. **DO NOT USE ABRASIVE ON SEMI-CON INSULATION SHIELD!**
 - Use only aluminum oxide abrasive; grit 120 or finer, included in the 3M Cable Cleaning Preparation Kit CC-2.
 - Be careful not to reduce the cable insulation diameter below that allowed by the kit.
- 15.2 Wipe the cable insulation with one of the solvent saturated pads from the 3M Cable Cleaning Preparation Kit CC-2 **AND ALLOW IT TO DRY BEFORE INSTALLING TERMINATION. DO NOT ALLOW SOLVENT TO TOUCH SEMI-CON INSULATION SHIELD!**

16.0 Install Termination

16.1 Slide the termination body onto the cable and remove core. Make sure the termination body (not the core) is butted up to the edge of the vinyl tape marker previously applied in Step 13.2 (Figure 24). Pull the core while unwinding, counter-clockwise, starting with the loose end (Figure 24). Be sure to alternate the pulling and unwinding actions (pull-unwind-pull-unwind-etc.) to help prevent the core material from binding up as the core is being removed.

NOTE: Once the termination body makes contact over the mastic seal area, there is no need to continue supporting the assembly. DO NOT PUSH OR PULL ON THE TERMINATION ASSEMBLY WHILE UNWINDING THE CORE.

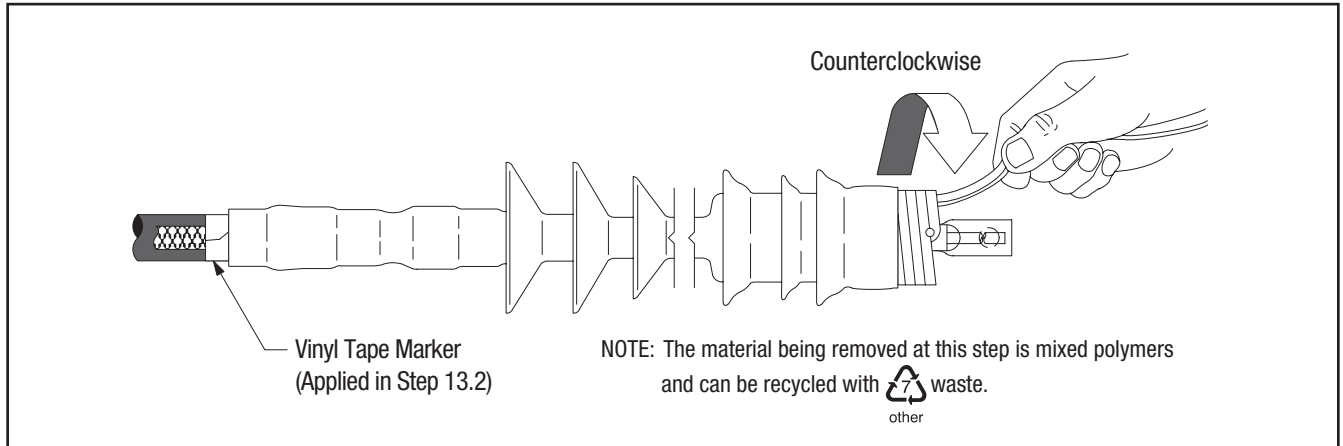
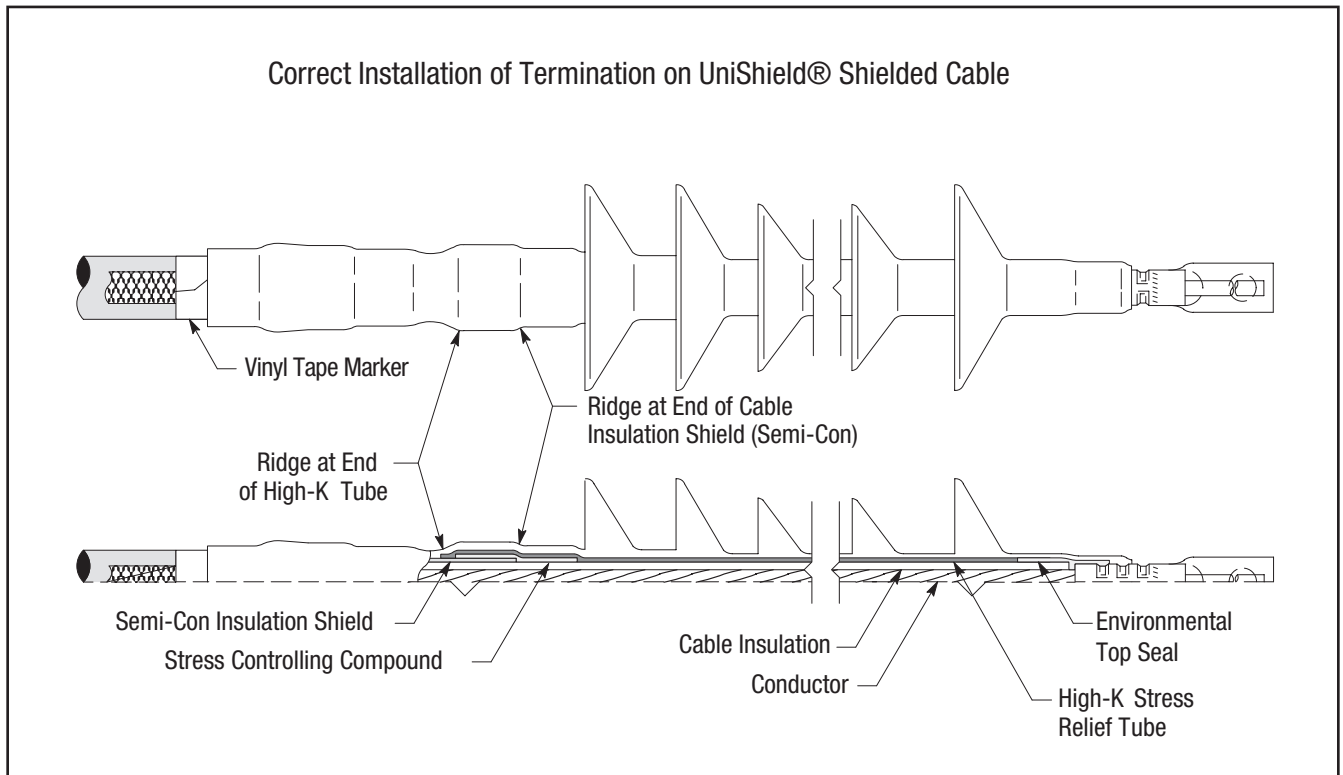
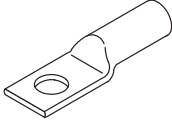
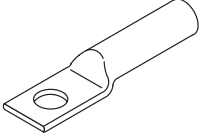
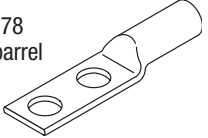

Figure 24

16.2 Connect ground braid to system ground according to standard practice.



Tooling Index

| Lug and Crimping Information for 3M™ Scotchlok™ Copper Lugs | | | | | | | | | | | | | |
|---|--------------------|----------------------------------|---|----------------------------|--------------------|--------------------------------------|--|-------------------------------------|----------------------------|--|--|--|---|
| 30014 thru 30045 One hole | | |  | | | | 31036 thru 31068 One hole-long barrel | | |  | 31145 thru 31178 Two hole-long barrel | |  |
| Crimping Tool-Die Sets (Minimum Number Of Crimps) | | | | | | | | | | | | | |
| Cable Size AWG/ kcmil | Stud Size (in.) | 3M™ Scotchlok™ Copper Lug Number | Burdny Corporation | | | | Thomas & Betts Corporation | | | Square D Co. Anderson Div. | | | |
| | | | MD6 | MY29 | Y34A | Y35, Y39, Y45*, Y46* | TBM 5 | TBM 8 | TBM 15 | VC6-3, VC6-FT** | | | |
| 6 | 10 1/4 5/16 | 30014 30015 30016 | - | 6AWG(1) | - | U5CRT(1) | Blue(1) | Blue(1) | - | (1) | | | |
| 4 | 10 1/4 3/8 | 30018 30019 30021 | W161(1) | 4AWG(1) | A4CR(1) | U4CRT(1) | Grey(1) | Grey(1) | - | (1) | | | |
| 2 | 1/4 5/16 3/8 | 30022 30023 30024 | W162(2) | 2AWG(1) | A2CR(1) | U2CRT(2) | Brown(1) | Brown(1) | 33(1) | (2) | | | |
| 1 | 5/16 3/8 | 30027 30028 | - | 1AWG(1) | A1CR(1) | U1CRT(2) | Green(1) | Green(1) | 37(1) | (2) | | | |
| 1/0 | 5/16 3/8 | 30031 30032 | W163(2) | 1/0(1) | A25R(1) | U25RT(1) | Pink(2) | Pink(2) | 42H(2) | (1) | | | |
| 2/0 | 3/8 3/8 | 30036 31036 | W241(2) W241(3) | 2/0(1) 2/0(2) | A26R(1) A26R(2) | U26RT(2) U26RT(3) | Black(2) Black(3) | Black(2) Black(3) | 45(1) 45(2) | (1) (2) | | | |
| 3/0 | 1/2 1/2 | 30041 31041 | W243(2) W243(3) | 3/0(1) 3/0(2) | A27R(1) A27R(2) | U27RT(2) U27RT(3) | Orange(2) Orange(3) | Orange(2) Orange(3) | 50(1) 50(2) | (2) (3) | | | |
| 4/0 | 1/2 1/2 1/2 | 30045 31045 31145 | BG(3) BG(4) BG(4) | 4/0(1) 4/0(2) 4/0(2) | A28R(2) | U28RT(2) U28RT(3) U28RT(3) | Purple(2) Purple(3) Purple(3) | Purple(2) Purple(3) Purple(3) | 54H(2) 54H(3) 54H(3) | (2) (3) (3) | | | |
| 250 | 1/2 1/2 | 31049 31149 | W166(4) | 250(2) | A29R(2) | U29RT(3) | Yellow(2) | Yellow(2) | 62(2) | (2) | | | |
| 300 | 1/2 1/2 | 31053 31153 | - | - | A30R(2) | U30RT(3) | - | White(3) | 66(3) | (3) | | | |
| 350 | 1/2 1/2 | 31056 31156 | - | - | A31R(2) | U31RT(3) | - | Red(4) | 71H(4) | - | | | |
| 400 | 1/2 1/2 | 31060 31160 | - | - | A32R(2) | U32RT(3) | - | Blue(4) | 76H(4) | - | | | |
| 500 | 1/2 5/8 1/2 | 31066 31067 31166 | - | - | A34R(2) | U34RT(3) | - | Brown(4) | 87H(4) | - | | | |
| 600 | 1/2 1/2 | 31068 31168 | - | - | - | U36RT(3) | - | Green(4) | 94H(4) | - | | | |
| 750 | 1/2 | 31172 | - | - | - | Y39, Y45, Y46 U39RT(5) | - | - | 106H(4) | - | | | |
| 1000 | 1/2 | 31178 | - | - | - | Y45: S44RT(6) Y46: P44RT(6) | - | - | 125H(4) | - | | | |

* Y45 and Y46 accept all Y35 dies ("U" series). For Y45 use PT6515 adapter. For Y46 use PUADP adapter.

** Anderson VC6-3 and VC6-FT require no die set.

Tooling Index

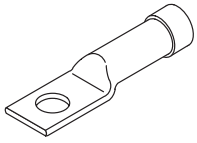
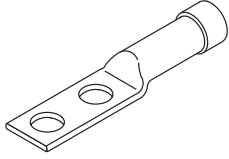
| Lug and Crimping Information for 3M™ Scotchlok™ Copper/Aluminum Lugs | | | | | | | | | | | | | | | |
|--|-----------------|------------------------------|---|---------|----------|-------------------------|---------|------------------------------|----------|---------|---|-------------------------------|--------|-------------------------|-------------------------|
| 40016 thru 40079 One hole | | |  | | | | | 40132 thru 40178 Two hole | | |  | | | | |
| Cable Size AWG/ kcmil | Stud Size (in.) | 3M™ Scotchlok™ Lug Number | Crimping Tool-Die Sets (Minimum Number Of Crimps) | | | | | | | | | | | | |
| | | | Burdny Corporation | | | | | Thomas & Betts Corporation | | | | Square D Co. Anderson Div. | | ITT Blackburn Co. | Kearny Nat'l Div. |
| | | | MD6 | MY29 | Y34A | Y35, Y39, Y45*, Y46* | Y1000** | TBM 5 | TBM 8 | TBM 12 | TBM 15 | VC6-3** VC6-FT** | VC8C** | OD58 | TYPE 0 |
| 6 | 5/16 | 40016 | W161(1) | 6AWG(1) | A6CAB(1) | U6CABT(1) | (1) | Grey(1) | Grey(1) | - | 29(1) | (1) | - | BY19(3) | J(3) |
| 4 | 5/16 | 40020 | W162(3) | 4AWG(1) | A4CAB(1) | U4CABT(1) | (1) | Green(2) | Green(2) | - | 37(1) | (1) | - | BY53(3) | P(3) |
| 2 | 3/8 | 40024 | W163(3) | 2AWG(1) | A2CAB(1) | U2CABT(1) | (1) | Pink(2) | Pink(2) | - | 42H(2) | (1) | - | BY23(3) | 1/2(3) |
| | 1/2 | 40025 | W163(3) | 2AWG(1) | A2CAB(1) | U2CABT(1) | (1) | Pink(2) | Pink(2) | - | 42H(2) | (1) | - | BY23(3) | 1/2(3) |
| 1 | 3/8 | 40028 | W163(3) | 1AWG(1) | A1CAR(1) | U1CART(1) | (1) | Gold(2) | Gold(2) | - | 45(1) | (1) | - | BY23(3) | 1/2(3) |
| | 1/2 | 40029 | W163(3) | 1AWG(1) | A1CAR(1) | U1CART(1) | (1) | Gold(2) | Gold(2) | - | 45(1) | (1) | - | BY23(3) | 1/2(3) |
| 1/0 | 3/8 | 40032 | W241(3) | 1/0(1) | A25AR(1) | U25ART(1) | (1) | Tan(2) | Tan(2) | - | 50(1) | (1) | - | BY25(3) | 5/8-1(3) |
| | 1/2 | 40033 | W241(3) | 1/0(1) | A25AR(1) | U25ART(1) | (1) | Tan(2) | Tan(2) | - | 50(1) | (1) | - | BY25(3) | 5/8-1(3) |
| | 3/8 | 40132 | W241(3) | 1/0(1) | A25AR(1) | U25ART(1) | (1) | Tan(2) | Tan(2) | - | 50(1) | (1) | - | BY25(3) | 5/8-1(3) |
| 2/0 | 1/2 | 40037 | BG(4) | 2/0(1) | A26AR(2) | U26ART(2) | (1) | Olive(2) | Olive(2) | - | 54H(2) | (2) | - | BY31C(3) | 5/8-1(3) |
| | 1/2 | 40137 | BG(4) | 2/0(1) | A26AR(2) | U26ART(2) | (1) | Olive(2) | Olive(2) | - | 54H(2) | (2) | - | BY31C(3) | 5/8-1(3) |
| 3/0 | 1/2 | 40041 | W166(4) | 3/0(1) | A27AR(2) | U27ART(2) | (1) | Ruby(2) | Ruby(2) | - | 60(2) | (2) | - | - | 737(3) |
| | 1/2 | 40141 | W166(4) | 3/0(1) | A27AR(2) | U27ART(2) | (1) | Ruby(2) | Ruby(2) | - | 60(2) | (2) | - | - | 737(3) |
| 4/0 | 1/2 | 40045 | W660(4) | 4/0 (2) | A28AR(2) | U28ART(2) | (1) | - | White(4) | - | 66(4) | (2) | - | BY35C(4) | 840(4) |
| | 5/8 | 40046 | W660(4) | 4/0 (2) | A28AR(2) | U28ART(2) | (1) | - | White(4) | - | 66(4) | (2) | - | BY35C(4) | 840(4) |
| | 1/2 | 40145 | W660(4) | 4/0 (2) | A28AR(2) | U28ART(2) | (1) | - | White(4) | - | 66(4) | (2) | - | BY35C(4) | 840(4) |
| 250 | 1/2 | 40049 | W249(3) | - | A29AR(2) | U29ART(2) | (1) | - | - | 71H(4) | 71H(2) | (3) | - | - | - |
| | 5/8 | 40050 | W249(3) | - | A29AR(2) | U29ART(2) | (1) | - | - | 71H(4) | 71H(2) | (3) | - | - | - |
| | 1/2 | 40149 | W249(3) | - | A29AR(2) | U29ART(2) | (1) | - | - | 71H(4) | 71H(2) | (3) | - | - | - |
| 300 | 1/2 | 40053 | - | - | A30AR(2) | U30ART(2) | (1) | - | - | 76H(4) | 76H(2) | (3) | - | - | - |
| | 1/2 | 40153 | - | - | A30AR(2) | U30ART(2) | (1) | - | - | 76H(4) | 76H(2) | (3) | - | - | - |
| 350 | 1/2 | 40056 | - | - | - | U31ART(2) | (1) | - | - | 87H(4) | 87H(3) | (3) | - | - | - |
| | 5/8 | 40057 | - | - | - | U31ART(2) | (1) | - | - | 87H(4) | 87H(3) | (3) | - | - | - |
| | 1/2 | 40156 | - | - | - | U31ART(2) | (1) | - | - | 87H(4) | 87H(3) | (3) | - | - | - |
| 400 | 1/2 | 40160 | - | - | - | U32ART(4) | (1) | - | - | 94H(4) | 94H(4) | - | (2) | - | - |
| 500 | 5/8 | 40067 | - | - | - | U34ART(4) | (1) | - | - | 106H(4) | 106H(3) | - | (2) | - | - |
| | 1/2 | 40166 | - | - | - | U34ART(4) | (1) | - | - | 106H(4) | 106H(3) | - | (2) | - | - |
| 600 | 1/2 | 40170 | - | - | - | U36ART(4) | (1) | - | - | - | 115H(3) | - | (3) | - | - |
| 750 | 5/8 | 40073 | - | - | - | U39ART(4) | (1) | - | - | - | 125H(4) | - | (3) | - | - |
| | 1/2 | 40172 | - | - | - | U39ART(4) | (1) | - | - | - | 125H(4) | - | (3) | - | - |
| 1000 | 5/8 | 40079 | - | - | - | S44ART(4) | (1) | - | - | - | 140H(4) | - | (3) | - | - |
| | 1/2 | 40178 | - | - | - | S44ART(4) | (1) | - | - | - | 140H(4) | - | (3) | - | - |

* Y45 and Y46 accept all Y35 dies ("U" series). For Y45 use PT6515 adapter. For Y46 use PUADP adapter.

** Anderson VC6-3, VC6-FT, VC8C and Burndy Y1000 require no die set.

Tooling Index

| Conductor Size AWG & kcmil | | 3M™ Connector Number | Crimping Table For 3M™ Stem Type Connector | | | | |
|-------------------------------|--------------------|----------------------------|--|------------|--------------------------|----------------------|--------------------------|
| Stranded | Solid | | Recommended Crimping Tools | | | | |
| | | | Manufacturer | Mech. Tool | Die (Minimum No. Crimps) | Hydraulic | Die (Minimum No. Crimps) |
| 2, 1 4 1/0 | 1, 1/0 2 2/0 | SC0001 SC0002 SC0010 | Burndy | MD6 | BG(4), W241(3) | Y35, Y39, Y45*, Y46* | U25ART(2), U243(2) |
| | | | Kearny | 0-51, 0-52 | 5/8-1 (4) | WH-1, WH-2 | 5/8-1(4) |
| | | | T & B | TBM 5 | Tan(2) | - | - |
| | | | T & B | TBM 8 | Olive(2), Tan(2) | TBM 15 | 50(2) |
| | | | Anderson | - | - | VC6** | (2) |
| 2/0 3/0 4/0 | 3/0 4/0 - | SC0020 SC0030 SC0040 | Burndy | MD6 | W249(3) | Y35, Y39, Y45*, Y46* | U28ART(2) |
| | | | Kearny | 0-51, 0-52 | 840(5) | WH-1, WH-2 | 840(2) |
| | | | T & B | TBM 8 | Red(4) | TBM 15 | 71H(3) |
| | | | Anderson | - | - | VC6** | (2) |

* Y45 and Y46 accept all Y35 dies ("U" series). For Y45 use PT6515 adapter. For Y46 use PUADP adapter.

** Anderson VC6 is dieless and does not require a die set.

3M, Scotch and Scotchlok are trademarks of 3M Company.

UniShield is a trademark of General Cable Technologies Corporation.

All other trademarks herein are the property of their respective owners.

Important Notice

All statements, technical information, and recommendations related to 3M's products are based on information believed to be reliable, but the accuracy or completeness is not guaranteed. Before using this product, you must evaluate it and determine if it is suitable for your intended application. You assume all risks and liability associated with such use. Any statements related to the product which are not contained in 3M's current publications, or any contrary statements contained on your purchase order shall have no force or effect unless expressly agreed upon, in writing, by an authorized officer of 3M.

Warranty; Limited Remedy; Limited Liability.

This product will be free from defects in material and manufacture at the time of purchase. **3M MAKES NO OTHER WARRANTIES INCLUDING, BUT NOT LIMITED TO, ANY IMPLIED WARRANTY OF MERCHANTABILITY OR FITNESS FOR A PARTICULAR PURPOSE.** If this product is defective within the warranty period stated above, your exclusive remedy shall be, at 3M's option, to replace or repair the 3M product or refund the purchase price of the 3M product. **Except where prohibited by law, 3M will not be liable for any direct, indirect, special, incidental or consequential loss or damage arising from this 3M product, regardless of the legal theory asserted.**



Electrical Markets Division

6801 River Place Blvd.
Austin, TX 78726-9000
800.245.3573
Fax 800.245.0329
www.3M.com/electrical

Please Recycle. Printed in USA.
© 3M 2015. All Rights Reserved.
78-8119-6019-0 Rev E