

Service Entrance Cable Fittings

Suggested Specifications for Service Entrance Fittings

- All service fittings shall be approved for the purpose by a nationally recognized testing laboratory, inspection agency, or product evaluation organization.
- Where service raceway consists of a rigid metal conduit, intermediate metal conduit, electrical metallic tubing or where service entrance cable is used as service conductors a suitable raintight service head conforming to Federal Standard W-C-586 shall be provided.
- Service raceway shall be securely fastened in place to the supporting surface at intervals as specified by the Code using suitable straps and spacers; straps and spacers shall be of malleable

iron or steel construction, hot dipped galvanized or electro zinc plated conforming to Canadian Standards Association Standard C22.2 No. 18.4 and as manufactured by Thomas & Betts: Series 1275 or 4175 straps and Series 1350 spacers; aluminum straps or spacers such as Series 1275AL and Series 1350AL may be substituted when installed in environmental conditions that are more than normally corrosive.

- For grounding and bonding of service raceway, end of raceway or the terminating fitting shall be equipped with bonding locknuts and insulated metallic grounding and bonding bushing as required.

Bonding locknuts shall be of hardened steel or malleable iron construction, electro zinc plated, and provided with hardened bonding screws as manufactured by Thomas & Betts, Series 106 bonding locknuts.

Insulated metallic grounding and bonding bushing shall be of malleable iron/steel construction, electro zinc plated and assembled with an insulator listed or certified for 150°C/302°F service as manufactured by Thomas & Betts, Series 3870.



**Series 4175
Pipe Strap (EMT)**



**Series 1275/1275AL Pipe Strap
(Rigid Metal Conduit & I.M.C.)**



**Series 1350/1350AL Pipe Spacer
(Rigid Metal Conduit I.M.C. & EMT)**



**Series 3870
Bonding & Grounding Bushing—
Insulated**



**Series 106
Bonding Locknut**

Service Entrance Cable Fittings

Suggested Specifications for Service Entrance Fittings (cont'd)

- Where service entrance cable is used as overhead service conductors and code requires use of a service head, entrance caps shall be installed; caps shall be cast metal type of suitable ferrous or non ferrous metal equipped with thermoset insulators and proper knockout openings; when installed with proper drip loop, caps must assure raintight conditions.
- Terminating fittings for service entrance cable (Type SE or USE) or underground feeder and branch — circuit cable (Type UF) in locations where exposed to intermittent or constant moisture or in dry locations and subjected to mechanical strain shall be of watertight strain relief type as manufactured by Thomas & Betts, Series 2111 or 2116-TB; fittings shall be constructed of ferrous or non ferrous metal and

equipped with taper-threaded hub, beveled moisture resistant/ oil resistant synthetic rubber bushing. In dry locations, nylon insulated two screw type fittings of malleable iron/steel construction, electro zinc plated inside and outside including threads, such as Series 3302M manufactured by Thomas & Betts may be substituted.

- Where service entrance cable is terminated into a threadless opening using hub type fittings, a gasket shall be provided between the outside of box or enclosure and fitting shoulder; gasket shall be of moisture resistant/oil resistant synthetic rubber type adequately protected by and permanently retained to a metallic retainer as manufactured by Thomas & Betts, Series 5262 or 5302.
- Service entrance cable shall be adequately supported at intervals enumerated in code using cable straps conforming to requirements of CSA Standard C22.2 No.18.4; cable straps shall be of malleable iron/steel construction, hot dipped galvanized or electro zinc plated as manufactured by Thomas & Betts, Series 1341.
- At the point where the service cable enters the building, a suitable sill plate shall be provided; sill/wall plate shall be sealed to assure raintight conditions.



Series 2111
Service Entrance Cable Fitting



Series 2116-TB
Underground Feeder Cable Fitting



Series 3302M
Two Screw Fitting (Insulated)



Series 5262, 5302
Sealing Gasket



Series 1341
Cable Strap

Service Entrance Cable Fittings

Application

- To connect service entrance cables to a meter box or an enclosure

Features

- Neoprene bushing, resists oil and water; grips cable the full length of the bushing providing adequate strain relief without damaging outer jacket (A)
- Taper-threaded body (B)
- Stainless steel retaining ring protects cable jacket against abrasion; reduces installing torque effort (C)
- Rugged ribbed steel gland construction (D)
- Suitable for Type USE I75, USE I90 and USE B90 (CEC Table 19) Service Entrance Cable

Standard Material/Finish

Body	Zinc Die Cast/As cast
Gland	Steel/Electro Zinc Plated & Chromate Coated
Retaining Ring	Stainless Steel/Passivated
Bushing	Neoprene/As molded

Range

- Oval (Flat) Cable Size 0.260 x 0.500 thru 1.062 x 1.765
- Type USE Cable Size 3 #12 thru 3-4/0 AWG Conductors
- Hub Size 1/2 in. thru 2 in. NPT (taper pipe threads)

Listing/Certification

CEC Rule 6-300 (1) add (b) use underground service entrance with mechanical protection as per CEC Rule 12-012

Conformity

UL514B, NEMA FB-1, Federal Standard H-28 (Threads), NFPA70-2009 (ANSI) CSA C22.2 No. 18.3

(Type SE/Type USE)

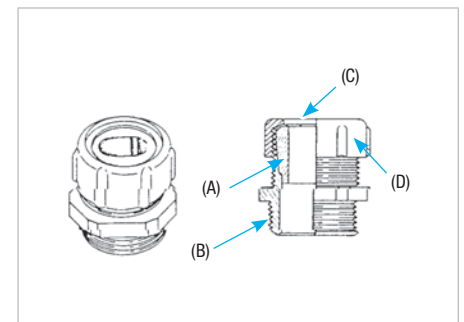

2111 Series

Underground Feeder Cable Fittings

Application

- To connect underground feeder cables to a box or an enclosure

Features

- Neoprene bushing resists oil and water; grips cable the full length of the bushing providing adequate strain relief without damaging outer jacket (A)
- Taper-threaded body (B)
- Stainless steel retaining ring protects cable jacket against abrasion; reduces installing torque effort (C)
- Rugged ribbed steel gland construction (D)

Standard Material/Finish

Body	Zinc Die Cast/As cast
Gland	Steel/Electro Zinc Plated & Chromate Coated
Retaining Ring	Stainless Steel/Passivated
Bushing	Neoprene/As molded

Range

- Oval (Flat) Cable Size 0.235 x 0.500 thru 0.260 x 0.740
- Hub Size 1/2 in. thru 1 in. NPT (tapered pipe threads)

Listing/Certification

CEC Rule 30-1004 (d) Wiring method, underground, where deviation has been allowed for permanent outdoor floodlighting installation.

Conformity

UL514B, NEMA FB-1, Federal Standard H-28 (Threads), NFPA70-2009 (ANSI) CSA C22.2 No. 18.3

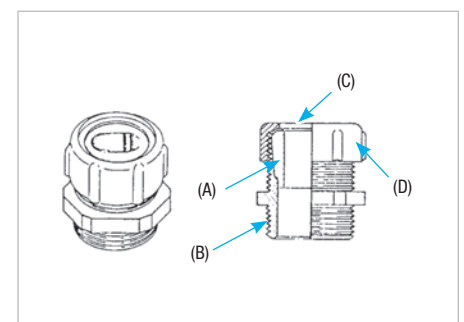

2116-TB Series

Service Entrance Cable Fittings

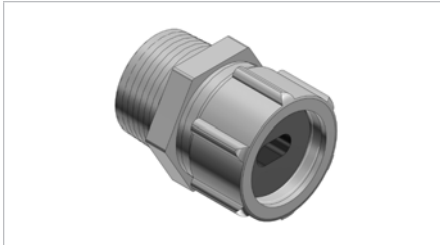

Oil and water resistant neoprene bushing is especially designed for sealing around underground feeder cable. Stainless steel retaining ring provides a bearing surface for the glandnut and eliminates cable twist. Ribbed gland nut is strong and easily tightened with a wrench to make a connection of high strength.

Underground Liquidtight Feeder Cable Fittings



Cat. No.	Hub Size (in.)	Cable Opening (in.)	Dimensions (in.)									
			A	B	C	D		E		F	G	H
						min.	max.	min.	max.			
2116-TB*	1/2	0.235 x 0.500	1-11/16	5/8	1	0.060	0.235	0.350	0.500	9/16	1-1/8	1-1/8
2237	3/4	0.230 x 0.430	1-9/16	9/16	1-7/32	0.080	0.230	0.320	0.430	13/16	1-3/8	1-3/8
2238	3/4	0.235 x 0.465	1-9/16	9/16	1-7/32	0.050	0.235	0.340	0.465	13/16	1-3/8	1-3/8
2239	3/4	0.240 x 0.685	1-9/16	9/16	1-7/32	0.060	0.240	0.500	0.685	13/16	1-3/8	1-3/8

* Not CSA Certified

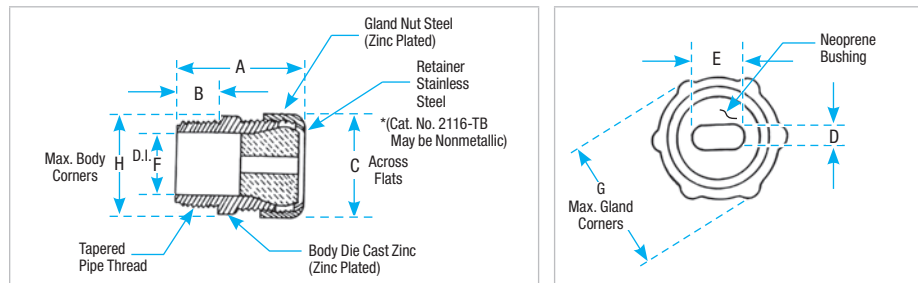

A design with two tapers inside the body — a slow one and a fast one — permits the stocking of fewer fittings for varied cable sizes and allows maximum take-up. The tapered neoprene bushings are resistant to oil, sunlight, and water. Hex gland and body take the same wrench opening and a stainless steel slip ring prevents cable from twisting as gland ring is being tightened. Threads on the body are tapered for water sealing.

Watertight Fittings for Oval Cables



Cat. No.	Hub Size (in.)	Dimensions (in.)					Overall Cable Range	
		A	B	C	D	E	min. (in.)	max. (in.)
2111	1/2	1-3/4	1-1/4	5/8	1-3/8	1-3/8	0.380 x 0.520	0.420 x 0.560
2232	3/4						0.260 x 0.500	0.385 x 0.600
2233		1-11/16	1-1/4	9/16	1-3/8	1-3/8	0.375 x 0.625	0.500 x 0.750
2234							0.490 x 0.675	0.555 x 0.800
2432	1						0.260 x 0.500	0.385 x 0.600
2433		1-11/16	1-1/4	9/16	1-3/8	1-3/4	0.375 x 0.625	0.500 x 0.750
2434							0.430 x 0.675	0.555 x 0.800
2438	1	1-3/4	1-1/2	25/32	1-11/16	1-3/4	0.440 x 0.730	0.565 x 0.855
2439							0.510 x 0.850	0.635 x 0.975
2442	1-1/4						0.510 x 0.850	0.635 x 0.975
2443		2-1/16	1-15/16	5/8	2-1/16	2-1/8	0.490 x 0.900	0.640 x 1.050
2446							0.565 x 0.965	0.750 x 1.150
2454	1-1/2	2-1/4	2-1/8	11/16	2-5/16	2-5/16	0.655 x 1.090	0.840 x 1.275
2447							0.695 x 1.240	0.880 x 1.425
2448	2						0.790 x 1.390	0.968 x 1.500
2449		2-3/8	2-5/8	11/16	2-3/4	2-13/32	0.850 x 1.550	1.062 x 1.765
2450							1.700 x 1.050	1.820 x 1.190

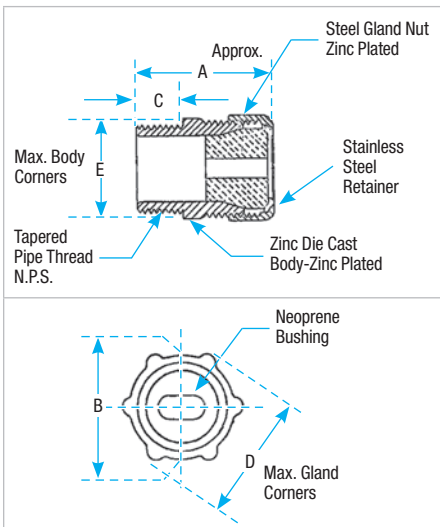

Service Entrance Cable Fittings



Each strap takes a wide range of sizes because of the rocking action of the foot. Hole is for 1/4 in. screw. Malleable iron, hot dipped galvanized construction.

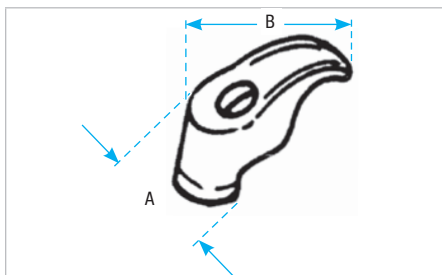

Cable Straps



Cat. No.	Wire Size	Dimensions (in.)	
		A	B
1341-TB	2-#10	5/8	1-1/8
1344	3-#6 or 3-#8	5/8	1-15/16
1345*	3-#4 or 3-#2	13/16	1-59/64
1346	3-1/0	3/4	2-7/16
1347	3-4/0	3/4	2-25/32

* Steel, hot dipped galvanized



Nylon UF Cable Fittings for Corrosive Environments



Cat. No.	Hub Size (in.)	UF Cable Range (in.)		Dimensions (in.)		
		min.	max.	A max.	B ± .060	C ± .060
2827	1/2	0.550 x 0.280	0.400 x 0.190	2.60	1.270	0.600
2828	3/4	0.675 x 0.280	0.525 x 0.190	3.00	1.570	0.620
2829	3/4	0.775 x 0.280	0.625 x 0.190	3.00	1.570	0.620

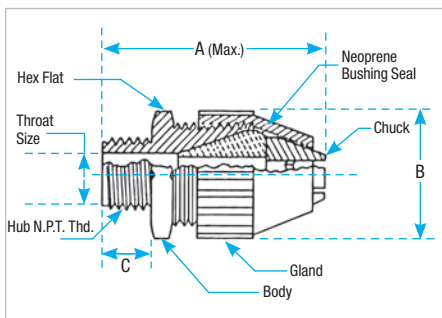

- Tapered threaded hub
- Liquidtight and dust-tight; hand tightens — no tools required
- Corrosion and weather resistant nylon for outdoor and indoor applications