

Submitted by: \_\_\_\_\_

Date: \_\_\_\_\_

Stamped Face Supply

Side Wall / Ceiling

Model:

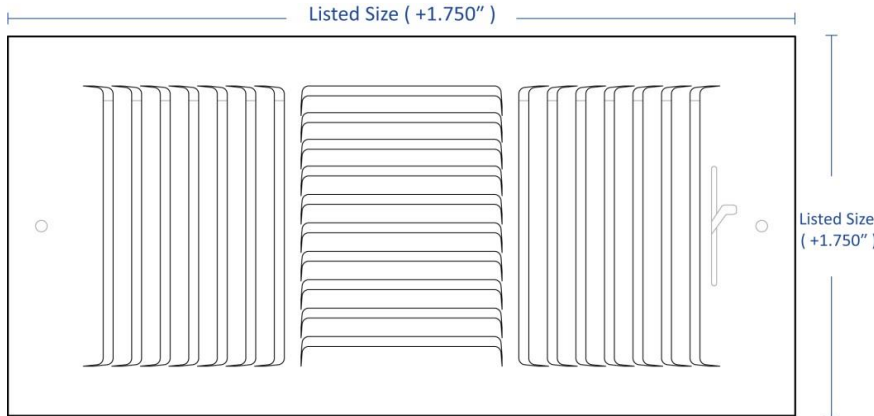

- Multi-shutter Damper
- Opposed Blade Damper

### Multi-Shutter Damper

±1 7/16"

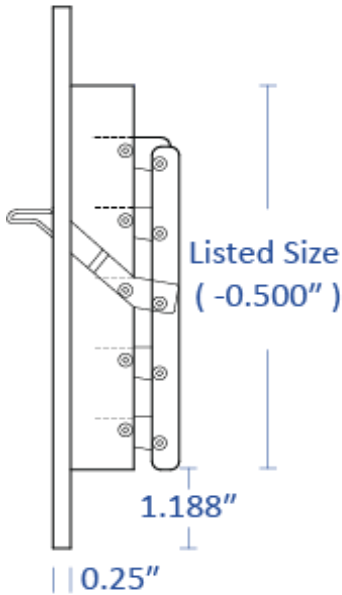

### Opposed Blade Damper

±1 11/16"

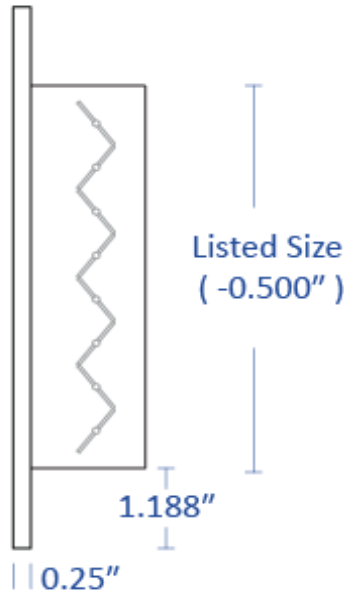

### Model Features

- Stamped 3 way pattern
- 1/2" fin spacing with 45° blade angle
- Durable white powder coat finish

**Material:** Steel

**Face:** Stamped

**Model Size:**

Project Name: \_\_\_\_\_

Architect: \_\_\_\_\_

Project Location: \_\_\_\_\_

Engineer: \_\_\_\_\_

Contractor: \_\_\_\_\_