

PeakFlow® A System Installation Instructions

PeakFlow® A Installation Instructions



Navien PeakFlow A is certified by IAPMO R&T to NSF/ANSI/CAN 61 Standard

WARNING

- To ensure maximum installation and functionality, please read this manual carefully BEFORE installing the equipment.
- Please follow the instructions carefully to avoid potential property damage or equipment damage that may result in personal injury. Installation must comply with state or municipal plumbing codes and regulations.
- Please keep this manual after installation. This manual contains important information on parts, maintenance, or troubleshooting including operational, maintenance, precautionary, and future references.
- The facility's personnel are strongly encouraged to read the Warnings, Operation and Maintenance sections of the manual

Introduction

The PeakFlow A System prevents scale build-up on the inner pipe surfaces of the heat exchanger inside the tankless water heater. When installing or using the filter, or when replacing the filter, be sure to refer to the manual.

Feed Water Chemistry Requirements

- pH: 6.5 to 8.5
- Hardness (maximum): 75 grains (1282 ppm CaCO₃)
- Water Pressure: 15 psi to 90 psi (1.03 bar to 6.2 bar)
- Temperature: 40°F to 100°F (5°C to 38°C)
- Chlorine (maximum): 2 ppm
- Iron (maximum): 0.3 mg/l
- Manganese (maximum): 0.05 mg/l
- Copper (maximum): 1.3 ppm
- Oil & H₂S: Must be removed before PeakFlow A



Model #GPWC310001AC001

System Specifications

- Maximum Pressure: 90psi / 6.2 bar
- Maximum Temperature: 100°F / 38°C
- Minimum Temperature: 40°F / 5°C
- Service Flow Rate: Up to 10 gpm (23 lpm)
- Continuous Flow Rate: Up to 6 gpm (15 lpm)
- Inlet/Outlet Connections: 1 " FNPT
- Capacity: Media cartridge does not have a grain removal capacity. However, other contaminants present in the water will gradually degrade the effectiveness of this cartridge (see Operation and Maintenance below).
- Polyphosphate: Must be removed before PeakFlow A
- Silica (maximum): 20 ppm
PeakFlow A + media does not reduce silica scaling. While silica tends to have a less significant effect on scale formation than other minerals, it can act as a binder that makes water spots and scale residue outside the plumbing system difficult to remove.

PeakFlow® A System Installation Instructions

NOTICE

To use the PeakFlow A System safely and effectively:

- The System cannot be used in conjunction with polyphosphate or any other scale inhibitor.
- The System cannot be used with microbiologically unsafe quality water.
- Confirm the direction of the water flow.
- The filter housing will be damaged by high temperatures.
- Be careful not to expose the system to freezing temperatures. When the temperature drops below 40°F, shut off the water supply to the housing and drain the housing.
- Avoid direct sunlight and do not install the system where it can be exposed to strong chemicals or bumped into equipment, carts, mops, or other items that could cause damage.
- If there is a water hammer, install a water hammer arrestor in front of the PeakFlow A System.

PeakFlow® A System Installation Instructions

NOTE: Please check the system package for any damaged or missing parts before proceeding with the installation.

Installation

1. Locate and turn off the water shut-off valve before installing the PeakFlow A System.
2. Inspect the water line for the use of polyphosphate or other scale inhibitors and remove if any. The PeakFlow A System cannot be used with other scale inhibitors.
3. Secure the PeakFlow A System mounting to a wall stud or an appropriate area spanning the wall stud and install the system to the mount. The System must be installed in vertical, upright, and level position.
4. Install the PeakFlow A system by checking if the direction of water flow is correct (following the arrow on the head).
5. When connecting the water supply line to the housing, apply about 2-3 Teflon® tape wraps to the threaded connections.
NOTE: Do NOT use liquid pipe compounds to connect fittings. Do not overtighten the housing entry and exit fitting connections.
6. Select tubing of the appropriate size for the equipment being supplied and connect it to the outlet of the PeakFlow A system.
7. If a drain valve is not installed on the outlet side of the System, hold the tube that will connect to the equipment over a clean bucket or sink or drain. Let the water flow through the System for two minutes at the specified system flow rate to allow air bubbles to escape.

Installation Drawings & Dimensions

Model		
PeakFlow A		
Dimensions		
	in.	mm
A	22.5	572
B	5.5	140
C	4	102
D	3.5	90
E	12	300

Due to variations and tolerances, please allow clearance above the filter for making connections.

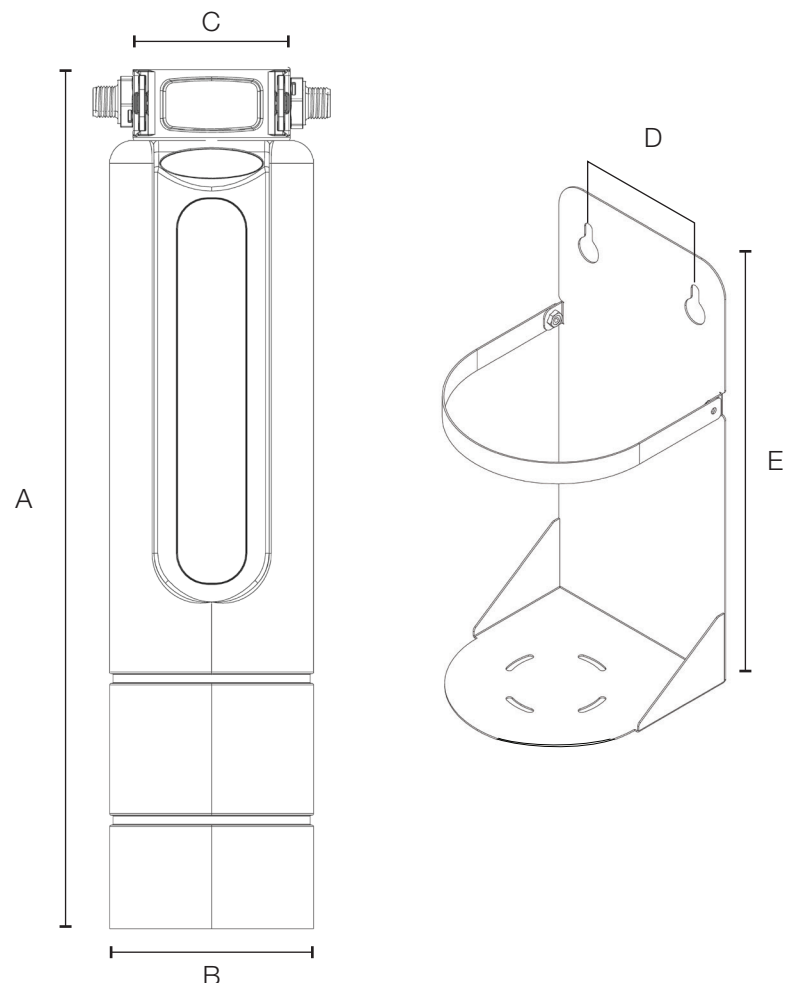

PeakFlow® A System Installation Instructions

System Mounting

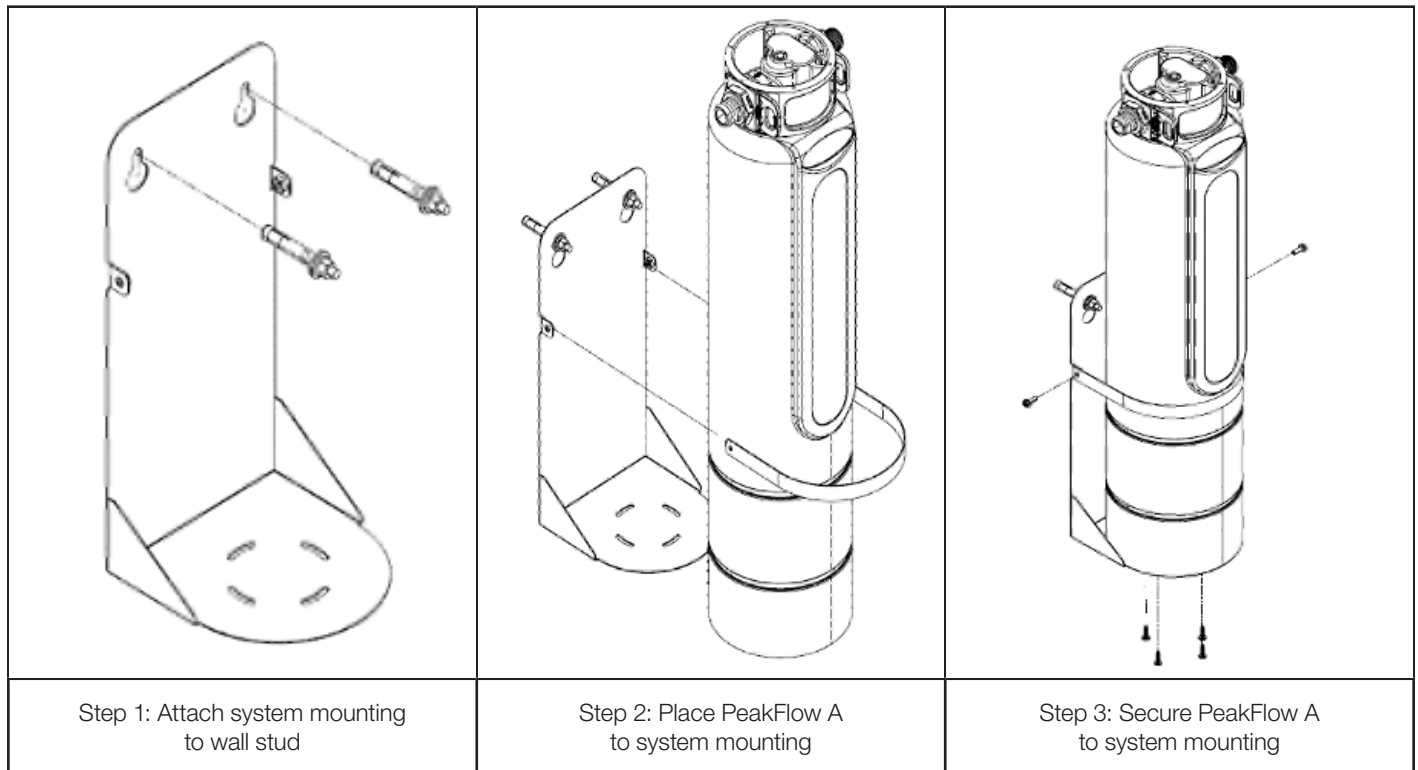

Operation and Maintenance

- The PeakFlow A system is a completely salt-free system.
- Scale prevention media needs to be replaced every 3 years.
- If the System sizing recommendations have been followed, the PeakFlow A media should last two years.
- Only PeakFlow A System media can be used.
- The use of any other replacement media will void the warranties and may compromise equipment protection, water quality, and equipment life.
- The filters should be changed 36 months after installation and at least 36 months after the last filter change. The frequency of cartridge replacement will depend on volume of system usage.

Media Replacement Procedure

1. Turn off all of the equipment connected to the PeakFlow A System before shutting off the water supply from the filters.
2. Shut off the water supply at the front end of the system.
3. Disconnect the plumbing line from the inlet and outlet.
4. Unscrew the head from the fiber glass tank. Then remove the distributor tube.
5. Remove the filter media by tipping the tank upside down into a large drum or pail.

PeakFlow® A System Installation Instructions

Media Bed Loading Procedure

1. Place the distributor tube back down the center of the tank. Plug top of the distributor tube with a rag or cork or tape to prevent media from entering.
2. Then pour the bag of media into the tank.

Note: it is important that the distributor tube is not moved or pulled during this process, as it is not possible to put it down the bottom of the tank once gravel and media are in the tank.

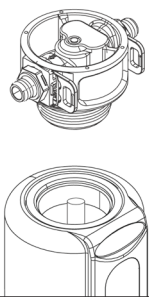
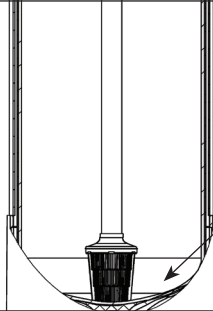
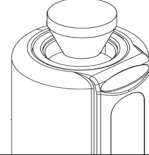
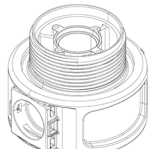
	 <p>The riser (distributor) remains inside the tank seated in the depression at the bottom</p>	 <p>Pour gravel, then media</p>
<p>Remove the adapter from the mineral tank</p> 	<p>Temporary plug the open end of the rise. The rise (distributor) remain inside the tank, seated in the depression at the bottom.</p>	<p>Fill the gravel (support bed) first. The media will not always spill down inside the tank and may need to be swept inside. The use of a funnel may make the filling of the tank easier and neater.</p>

Parts

Description	Quantity
20 inch glass fiber tank with a black jacket	1 EA
IN/OUT HEAD C/W 3/4" FITTINGS	1 EA
STD 1.05 OD DISTRIBTUION TUBE	1 EA
WALL BRACKET	1 EA
SCREWS FOR BRACKET	4 EA
CARTON, BROWN, TANK	1 EA
Resin, "AraGone" TM	1 LT

PeakFlow® A System Installation Instructions

Limited Warranty

Navien, Inc. warrants the PeakFlow A Scale Prevention System as follows:

- Navien warrants that the system is free of defects in material and workmanship for one year from the date of installation if the System is correctly installed according to the manual.

Conditions

1. The PeakFlow A Scale Prevention System works only when the incoming water complies with EPA regulations. Grease, copper, phosphate, silica, chlorine, and copper levels of the incoming water should meet the EPA drinking water standard.
2. The concentration of chlorine of incoming water should not exceed 2.0 ppm. If water supply exceeds 2.0 ppm of chlorine, a pretreatment system must be used to reduce chlorine levels under 2.0 ppm.
3. Abuse of the product, improper installation, or damage caused by the installer or user's mistake shall void this warranty.
4. The equipment must comply with local piping regulations and be installed and operated in a water supply system that complies with EPA drinking water standards.
5. The equipment is restricted to use at the water pressure and temperature that does not exceed the specifications suggested by Navien, Inc.
6. Information including the model number, serial number, and installation date must be provided for all claims related to the device warranty.
7. Either Navien, Inc. or an authorized Navien representation shall inspect any allegedly defective parts. Navien, Inc. shall adjust the coverage.
8. Navien, Inc. reserves the right to change or replace parts or equipment with materials of the same quality or value.

How do I get service?

- 0-30 days after purchase: Any accessory furnished by Navien Inc., installed and determined to be defective for up to 30 days must be returned to the wholesaler where purchased. Wholesaler shall handle the return through Sales Orders at orders@navien.com. A sales return authorization (SRA), purchase order copy and proper documentation will be required in order to receive a refund. Only approved credit will be issued.
- 31-365 days after purchase: Accessories installed for 31 days up to one year will require a Returned Goods Authorization (RGA) obtained by Navien's technical support team at 800-519-8794, option 2. An RGA number will be issued for shipping a replacement part or wholesaler pick up. Proof of purchase may be required based on product part value.

Limitations

Our obligation under this warranty is limited to providing a replacement or repairing at our option regarding the media cartridge. Parts that have been proven to be defective within the warranty period specified above will have replacement parts will be delivered to the owner of the PeakFlow scale prevention system. Labor costs are not included in the warranty.

Our warranty must satisfy the conditions under which the consumer provides media replacement within two years. Media is limited to products provided by Navien, Inc. This warranty does not include media damage due to chlorine or other oxidizing agents, contamination caused by local water quality conditions, or other conditions when used outside the limits indicated in the specifications and specifications.

NAVIEN, INC. MAKES NO OTHER WARRANTY, WHETHER EXPRESS OR IMPLIED. NAVIEN, INC. HEREBY SPECIFICALLY DENIES ALL OTHER EXPRESS OR IMPLIED WARRANTIES, INCLUDING, BUT NOT LIMITED TO, THE IMPLIED WARRANTIES OF MERCHANTABILITY AND FITNESS FOR PARTICULAR PURPOSE.

THE REMEDIES DESCRIBED IN THIS WARRANTY ARE THE ONLY AND EXCLUSIVE REMEDIES FOR VIOLATION OF THE WARRANTY. NAVIEN, INC. IS NOT RESPONSIBLE FOR INCIDENTAL, SPECIAL, OR CONSEQUENTIAL DAMAGES, INCLUDING, BUT NOT LIMITED TO, FREIGHT, HANDLING, LOSS OF PROFITS, EXPENSES, OR THE COST OF REPAIRING OR REPLACING OTHER PROPERTY THAT IS DAMAGED IF THIS PRODUCT DOES NOT WORK CORRECTLY, OTHER COSTS RESULTING FROM LABOR CHARGES, DELAYS, VANDALISM, NEGLIGENCE, FOULING CAUSED BY FOREIGN MATERIAL, DAMAGE FROM ADVERSE WATER CONDITIONS, CHEMICALS, OR ANY OTHER CIRCUMSTANCES OVER WHICH NAVIEN, INC. HAS NO CONTROL. THIS WARRANTY SHALL BE INVALIDATED BY ANY ABUSE, MISUSE, MISAPPLICATION, OR IMPROPER INSTALLATION OF THE PRODUCT.

This warranty gives you specific legal rights, and each state has different rights. To determine your rights, you must refer to your applicable state laws. All implied warranties are limited to the specified warranty period of the express warranties provided herein.

Some states do not allow restrictions on implied warranties or the exclusion or limitation of ancillary warranties or consequential damages. Those restrictions in this warranty may not apply to you.

CALIFORNIA PROPOSITION 65 WARNING
WARNING: This product contains chemicals known to the State of California to cause cancer and birth defects or other reproductive harm
(California law requires this warning to be given to customers in the State of California.)

Navien Inc., 20 Goodyear, Irvine, CA 92618 800-519-8794 Navieninc.com

