

Submittal Data: UTR-H0908L

Separation Tube

Header Total Capacity Less than 96.5 MBH

Job Name: _____

Date: _____

Location: _____

Approval: _____

Engineer: _____

Construction: _____

Submitted to: _____

Unit #: _____

Submitted by: _____

Drawing #: _____

Reference: _____

	Gas Pipe	Liquid Pipe	Closed Pipe
UTR-H0908L			
	Insulation	Closed Pipe Insulation	Binder
	Large 1 pcs Small 1 pcs	8 pcs	10 pcs
			ø6.35 (1/4) 6 pcs ø9.52 (3/8) 4 pcs ø12.7 (1/2) 2 pcs

UTR-H0908L

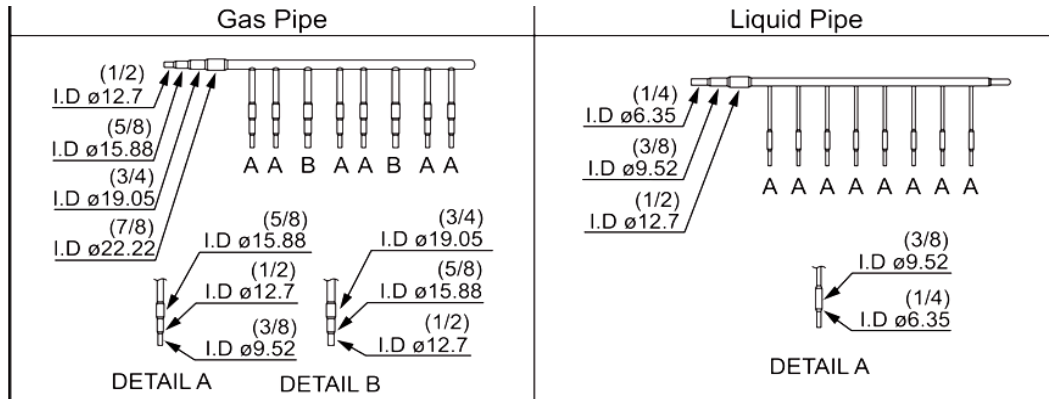

Note: Specifications are based on the following conditions:
 Cooling: Indoor temperature of 80°F (26.7°C) DB/67°F (19.4°C) WB, and outdoor temperature of 95°F (35°C) DB/75°F (23.9°C) WB.
 Heating: Indoor temperature of 70°F (21.1°C) DB/60°F (15.6°C) WB, and outdoor temperature of 47°F (8.3°C) DB/43°F (6.1°C) WB.
 Pipe length: 25ft.(7.5 m), Height difference: 0ft. (0m) (Outdoor unit - Indoor unit). Built-in protective functions may limit capacity or shut off unit if unit is operated outside of unit design operating temperature ratings.