

INSTALLATION MANUAL

THERMOSTAT CONVERTOR

For authorized service personnel only.

English

MANUEL D'INSTALLATION

CONVERTISSEUR DE THERMOSTAT

Pour le personnel agréé uniquement.

Français

MANUAL DE INSTALACIÓN

CONVERTIDOR DE TERMOSTATO

Únicamente para personal de servicio autorizado.

Español

UTY-TTRX
UTY-TTRXZ1

FUJITSU GENERAL LIMITED



[Original instructions]

PART NO. 9374707270-01

INSTALLATION MANUAL

PART NO. 9374707270-01
THERMOSTAT CONVERTOR

Contents

1. SAFETY PRECAUTIONS	1
2. MAIN UNIT AND ACCESSORIES	1
3. ELECTRICAL REQUIREMENT	1
4. SELECTING AN INSTALLATION LOCATION	2
4. 1. Dimensions	2
4. 2. Specifications	2
5. WIRING	2
5. 1. Wiring method	3
5. 2. Unit wiring	4
6. INSTALLING THE THERMOSTAT CONVERTOR	4
6. 1. Connecting the cables	4
7. CONNECTION OF REMOTE CONTROLLER CABLE	5
8. CIRCUIT BOARD SETTING	6
9. TURNING ON THE POWER	7
10. LED DISPLAY	7
10. 1. Normal code	7
10. 2. Error code	7
11. USAGE	7

1. SAFETY PRECAUTIONS

- The "SAFETY PRECAUTIONS" indicated in this manual contain important information pertaining to your safety. Be sure to observe them.
- Request the user to keep this manual on hand for future use, such as for relocating or repairing the unit.

 WARNING	This mark indicates procedures which, if improperly performed, might lead to the death or serious injury of the user.
Perform electrical work by an authorized service personnel in accordance with this manual and the electrical wiring regulations or implementation regulations of the country. Also do not install this product by yourself. Improper electric work will cause electric shock or a fire.	
Perform installation work in accordance with this manual. Request an authorized service personnel to perform installation work. Do not install this product by yourself. Improper installation will cause injury, electric shock, fire, etc.	
In the event of a malfunction (burning smell, etc.), immediately stop operation, turn off the electrical breaker, and consult authorized service personnel.	
Do not install the unit in the following areas: <ul style="list-style-type: none"> • Do not install the unit near a source of heat, steam or flammable gas. • Area filled with mineral oil or containing a large amount of splashed oil or steam, such as a kitchen. It will deteriorate plastic parts, causing the parts to fail or the unit to leak water. • Area that generates substances that adversely affect the equipment, such as sulfuric gas, chlorine gas, acid or alkali. It will cause the copper pipes and brazed joints to corrode, which can cause refrigerant leakage. • Area containing equipment that generates electromagnetic interference. It will cause the control system to malfunction, preventing the unit from operating normally. • Area that can cause combustible gas to leak, contains suspended carbon fibers or flammable dust, or volatile inflammables such as paint thinner or gasoline. If gas leaks and settles around the unit, it can cause a fire. • Install the unit in a well-ventilated place avoiding rains and direct sunlight. 	
Do not operate this product when your hands are wet. Touching the unit with wet hands will cause an electric shock.	
If children may approach the unit, take preventive measures so that they cannot reach the unit.	



 CAUTION	This mark indicates procedures which, if improperly performed, might possibly result in personal harm to the user or damage to property.
Pay abundant care when transporting this product because it is a precision device. Improper transportation will cause trouble.	
Do not touch the switches with sharp objects. Doing so will cause injury, trouble, or electric shock.	
Do not expose this product directly to water. Doing so will cause trouble, electric shock, or heating.	
Do not set vessels containing a liquid on this product. Doing so will cause heating, fire, or electric shock.	
Dispose of the packing materials safely. Tear and dispose of the plastic packing bags so that children cannot play with them. There is the danger of suffocation if children play with the original plastic bags.	

NOTES:

This product is manufactured to metric units and tolerances. United States customary units are provided for reference only. In cases where exact dimensions and tolerances are required, always refer to metric units.

2. MAIN UNIT AND ACCESSORIES

The following installation parts are supplied. Use them as required.

Name and Shape	Q'ty	Application
Thermostat convertor 	1	This product
Installation manual 	1	This manual
Screw (M4 x 16 mm) 	2	For mounting this product

3. ELECTRICAL REQUIREMENT

Use	Size	Cable type	Remarks
Remote controller cable (2-wire type)	16~22AWG (0.33 to 1.25 mm ²)	Sheathed PVC cable*	Non-polar 2 core, twisted pair Maximum cable length: 1,640 ft (500m)
Remote controller cable (3-wire type)	22AWG (0.33 mm ²)	Sheathed PVC cable*	Polar 3core Maximum cable length: 82 ft (25m)
Thermostat wires	18AWG (0.82 mm ²)	Sheathed PVC cable*	Maximum cable length: 164 ft (50m)

*: Use shielded cable in accordance with local rules for remote controller cable.

4. SELECTING AN INSTALLATION LOCATION

4.1. Dimensions

This product is comprised of a body and cover.

Unit : in (mm)

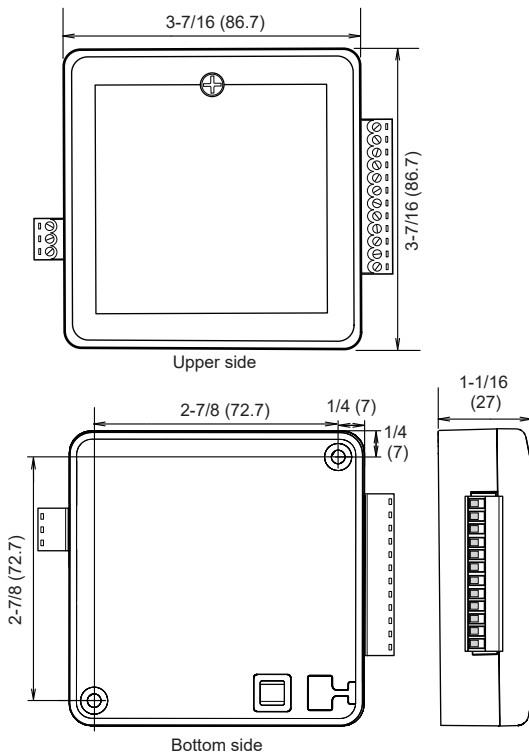

Set the bottom side to a flat place.

4.2. Specifications

Power consumption (W)		0.6
Temperature °F (°C)	Operating	32–114 (0–46)
	Packaged	14–140 (-10–60)
Humidity (%)	Packaged	0–95 (RH); No condensation
	Dimensions H x W x D in (mm)	1-1/16 x 3-7/16 x 3-7/16 (27 x 86.7 x 86.7)
Weight oz. (g)		4 (100)

5. WIRING

⚠ WARNING

Before starting installation work, turn off the power of this product and the connection destination. Do not turn on the power again until installation is completed. Otherwise, it will cause electric shock or fire.

Use the accessories or specified connection cable. Do not modify power supply cable and connection cables other than those specified, do not use extension cables, and do not use independent branch wiring. It may cause electric shock or fire.

Install the connection cables securely to the terminal block. Confirm that external force of the cable is not applied to the terminal block. Use the specified cables. If intermediate connection or insertion fixing are imperfect, it will cause electric shock, fire, etc.

When connecting the connection cable, route the cables so that the cover of this product is securely fixed. If the cover is imperfectly fixed, it may cause fire or overheating of the terminals.

Perform earth (ground) work positively. Do not connect the earth (ground) cable to a telephone cable, water pipe, or conductor rod.

Perform all wiring works so that the user does not touch the wiring. Otherwise it will cause injury or electric shock.

If any cable is damaged, do not repair or modify it yourself. Improper work will cause electric shock or fire.

⚠ CAUTION

Do not bind the remote controller cable and the external input cable together with or parallel to the power supply cable of the indoor and outdoor units. It may cause erroneous operation.

When performing wiring work, be careful not to damage the cable or injure yourself. Also, connect the connectors securely. Loose connectors will cause trouble, heating, fire, or electric shock.

Install the indoor unit, outdoor unit, power supply cable, transmission cable and remote control cable at least 40 in (1 m) away from a television or radio.

The purpose of this is to prevent TV reception interference or radio noise. (Even if they are installed more than 40 in (1 m) apart, you could still receive noise under some signal conditions.)

Perform wiring so that water does not enter this product along the external wiring. Always install a trap to the wiring or take other countermeasures. Otherwise it will cause trouble or electric shock or fire.

Confirm the name of each unit and name of each terminal block of the unit and connect the wiring in accordance with the directions given in the manual so that there is no incorrect wiring. Incorrect wiring will damage the electric parts and cause smoke and fire.

When installing the connection cables near a source of electromagnetic waves, use shielded cable. Otherwise, a breakdown or malfunction could result.

The terminal screws and earth (ground) screws have different shapes. Be sure to install the screws in the correct locations. If the screws are installed in the wrong locations, the circuit board could be damaged.

5.1. Wiring method

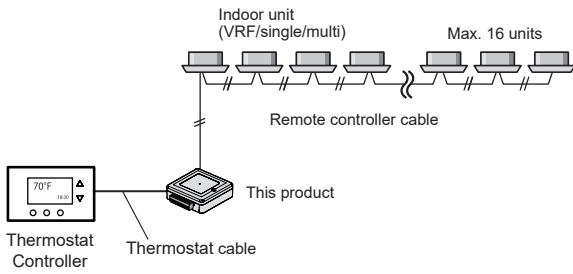

The connection example of thermostat converter and thermostat controller is shown below.

The connection method is different depending on the type of thermostat controller. Connect them according to the following Cases.

For remote controller cable, 2 kinds of type, which are 2-wire type and 3-wire type are available depending on the device to be connected.

- (1) All wiring shown should be performed with 18 AWG thermostat wire.
- (2) Terminals to thermostat controller on this product support 20-30VAC.
- (3) High/medium/low fan signals are optional, and may not be available on all thermostat models.
- (4) W2 and Y2 signals are optional, and may be omitted for single-stage thermostats. In addition, if Y2 and W2 are used, turn ON the DIP switches SET3-1.

Case 1: Two-stage Cooling and Heating (Example: Remote controller for 3-wire type)

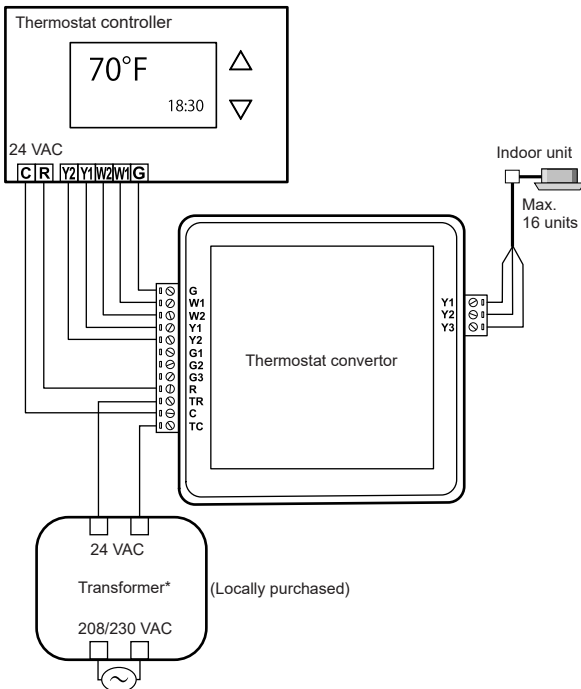

* Install the transformer, as necessary, per building code and manufacturer's installation instructions. Maximum Power: 5.0VA

Case 2: Single-stage Cooling and Heating (Example: Remote controller for 2-wire type)

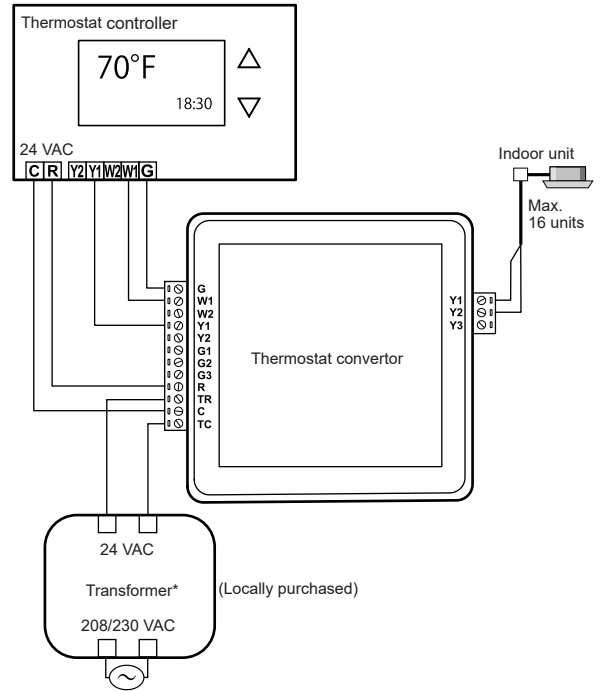

Case 3: Single-stage Cooling and Heating with Dedicated Fan Speed Relays (Example: Remote controller for 2-wire type)

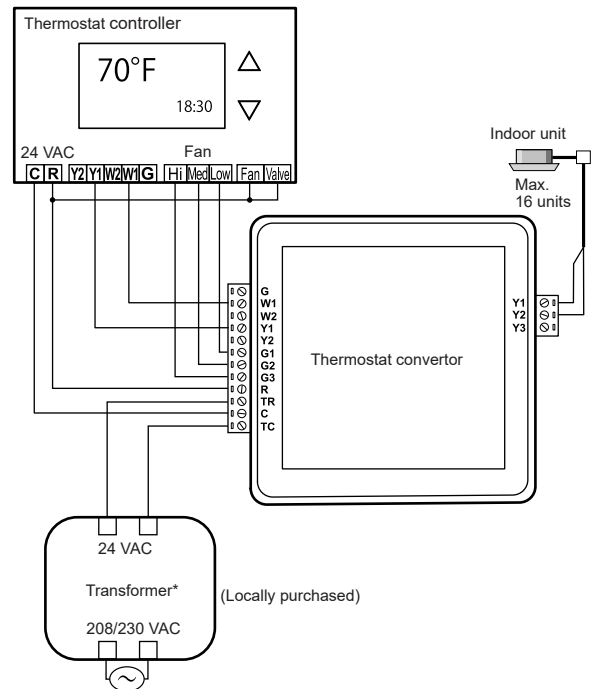

The names of terminal connected to thermostat have the following meanings.

TC	Common (In) from transformer
C	Common to thermostat controller
TR	Power supply from transformer
R	Power supply to thermostat controller
G3	Airflow High
G2	Airflow Medium
G1	Airflow Low
Y2	Cooling Stage 2
Y1	Cooling Stage 1
W2	Heating Stage 2
W1	Heating Stage 1
G	Fan

NOTES:

- Up to 16 indoor units may be controlled with a single thermostat controller. Multiple indoor units connected to convertor operate by the same operating setting.
- Two or more types of VRF1 system, VRF2 system, single model or multi split systems cannot be mixed together.

5.2. Unit wiring

5.2.1 Thermostat cable and Remote controller cable

Thermostat cable

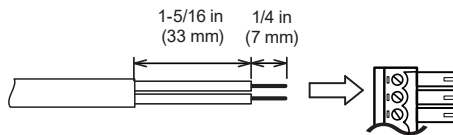

Remote controller cable

For 2-wire type

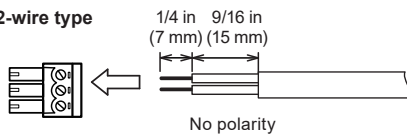

For 3-wire type

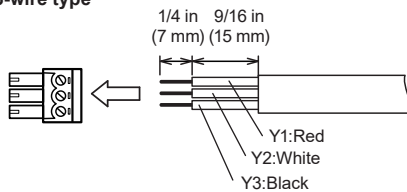

⚠ WARNING

Tighten the terminal screws to the specified torques, otherwise, abnormal overheating may be occurred and possibly cause heavy damage inside the unit.

Tightening torque

M2 screw	1.9 to 2.2 lbf-in (0.22 to 0.25 N·m)
Remote controller / Y1, Y2, Y3	2.2 to 2.5 kgf-cm
Thermostat input / G, W1, W2, Y1, Y2, G1, G2, G3, R, TR, C, TC	

⚠ CAUTION

To peel the sheath from the cables, use a dedicated tool that will not damage the conductor of the cable.

When installing a screw on the terminal block, do not cut the cable by overtightening the screw. On the other hand, a loosen screw can cause faulty contact, which will lead to a communication failure.

6. INSTALLING THE THERMOSTAT CONVERTOR

⚠ WARNING

Always use the accessories and specified installation work parts. Check the state of the installation parts. Not using the specified parts will cause units to fall off, electric shock, fire, etc.

Install at a place that can withstand the weight of the unit and install positively so that the unit will not topple or fall.

When installing this product, make sure that there are no children nearby. Otherwise, injury or electric shock could result.

⚠ CAUTION

Do not set the DIP switch of this product except as specified in this installation manual or the instruction manual supplied with the air conditioner. Setting the switches other than specified will cause an accident or trouble.

Use an insulated screwdriver to set the DIP switches.

Before opening the cover of this product, completely discharge static electricity charged on your body. Otherwise, failure or malfunction could result.

Do not touch the circuit board and circuit board parts directly with your hands. Otherwise, injury or electric shock could result.

Tightening the mounting screws too tight will damage the body of this product.

- When connecting this product to an indoor unit that does not support Fan mode, do not connect any G (Fan), G1, G2, and G3 signals. Otherwise air conditioner might operate incorrectly.
- If connecting this product to a heat pump system of VRF, please select " Priority on Administrative Indoor Unit" in the setting of priority mode by PUSH SWITCH of outdoor unit (refer to installation manual of outdoor unit). Furthermore, please complete "Administrative Indoor Unit Setting" for indoor unit which is connected to this Thermostat Converter by using the wired remote controller (refer to installation manual of remote controller.) This setting is not required for signal zone and multi zone systems.

NOTES:

When this product is used, do not use any other controllers because the indoor units are controlled centrally by the thermostat controller.

However, the remote controller connecting is temporarily required for the initial setting. During the initial setting by remote controller do not connect Thermostat Converter to indoor unit.

After when all initial setting is completed, disconnect the wired remote controller. Then connect Thermostat Converter to indoor unit at first time.

6.1. Connecting the cables

- (1) For thermostat cable, use the single wire of 18AWG thermostat wire.
- (2) Power-supply voltage of thermostat (TC, TR) is 20 to 30VAC.
- (3) Insert the cable to the connected terminal and fix with screw using screw driver.
- (4) For remote controller cable, 2 kinds of 2 kinds of type, which are 2-wire type and 3-wire type are available depending on the device to be connected.
- (5) The number of connected thermostat cable is different the type of thermostat controller.
- (6) For details of connection method, refer to Case 1 to Case 3 of "5. Wiring".

7. CONNECTION OF REMOTE CONTROLLER CABLE

⚠ CAUTION

When connecting the remote controller cable to the indoor unit, do not connect it to the outdoor unit or the power terminal block. It may cause a failure.

When connecting Indoor unit and thermostat converter with the Remote controller cable, the following items should be considered.

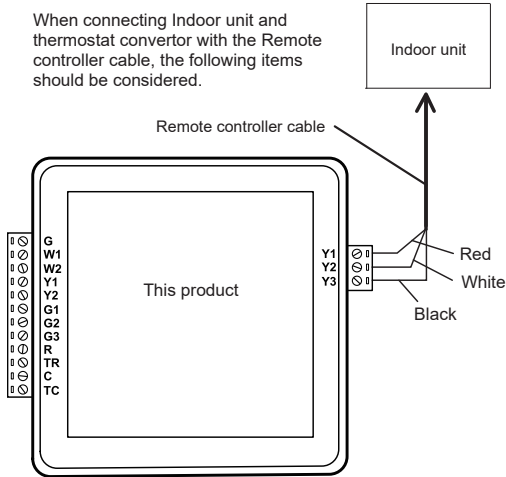

There are 2 methods to connect the remote controller cable to the indoor unit. One is the connection using connecting cable contained by indoor unit, and the other is the connection the remote controller cable is connected to the exclusive terminal block of the indoor unit.

Exclusive terminal block for remote controller connection method is different depending on each model. Modify the remote controller cable as per below description and connect it.

(For the details, refer to the installation manual of the indoor unit to be used.)

(1) When connecting to the connector

Case 1: For non-polar 2-wire

Use a tool to cut off the terminal on the end of the remote controller cable, and then remove the insulation from the cut end of the cable as shown in Fig. 1. Connect the remote controller cable and connecting cable as shown in Fig. 2. Be sure to insulate between the cables.

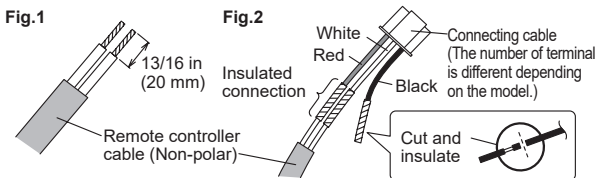

Insert it to the connector. Set to "2WIRE" the DIP switch (SW1) on the PC board of the indoor unit.

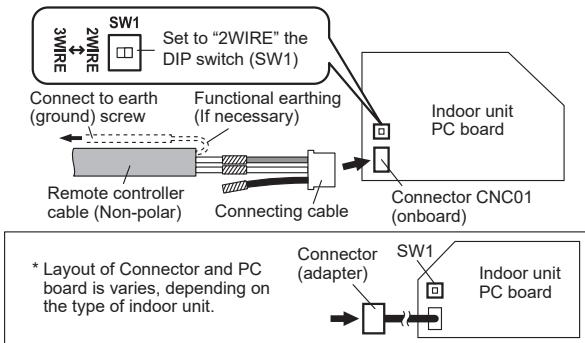

Case 2: For polar 3-wire

Modify the cable as per below methods.

Use a tool to cut off the terminal on the end of the remote controller cable, and then remove the insulation from the cut end of the cable as shown in Fig. 1.

Connect the remote controller cable and connecting cable as shown in Fig. 2.

Be sure to insulate between the cables.

Fig. 1

Fig. 2

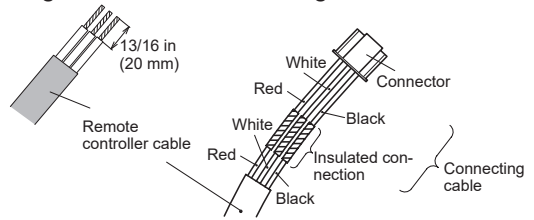

Insert it to the connector.

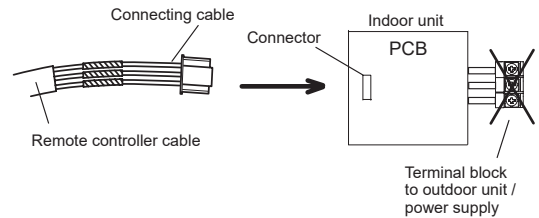

When the board has the 2WIRE/3WIRE DIP switch on it, set it to 3WIRE.

For how to set, see "Case 1: For non-polar 2-wire".

(2) When connecting to the exclusive terminal block

Connect the end of remote controller cable directly to the exclusive terminal block.

If there is the 2WIRE/3WIRE switch on the PC board of the indoor unit, set it to match the connection method of the connected remote controller cable.

Example) Connection of non-polar 2-wire

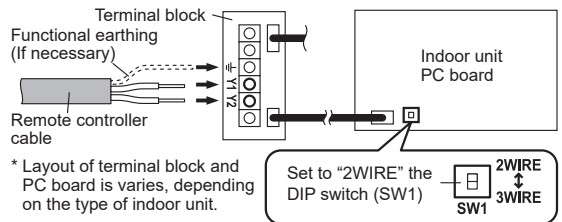

8. CIRCUIT BOARD SETTING

Remove the cover of main unit by the following procedure to perform the initial setting.

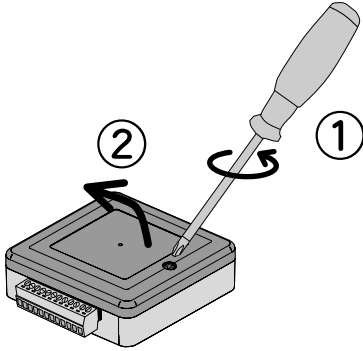

Tightening torque	
M3 screw	4.4 to 5.3 lbf-in (0.5 to 0.6 N·m) (5 to 6 kgf·cm)

When the cover is removed, the circuit board appears.

The circuit board has DIP switches and LEDs as shown below.

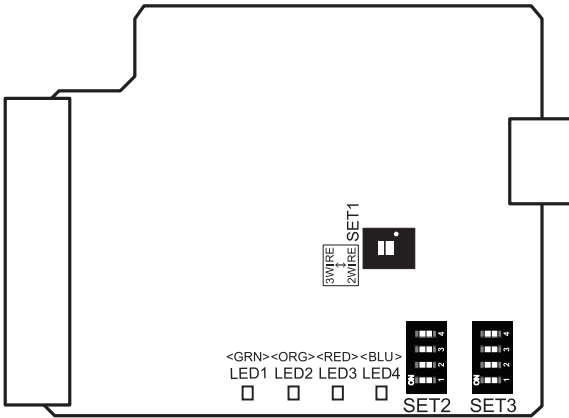

Perform the initial setting using 3 DIP switches (SET 1 to 3) on the circuit board.

(1) 2WIRE/3WIRE setting (SET1)

Remote controller 2WIRE/3WIRE switching SW

"Factory setting : 2WIRE"

Set matched with the connection method of the remote controller cable to be connected.

(2) Single-stage or Two-stage setting

SW SET3-1	Contents
OFF★	Temperature setting: Single-stage
ON	Temperature setting: Two-stage

(★: Factory setting)

(3) Temperature setting

(3)-1 Single-stage setting

Cooling setting temperature

SW SET3-2	Cooling Stage 1 setting temperature °F (°C)	Remarks
OFF★	64 (18)	Pattern1
ON	68 (20)	Pattern2

(★: Factory setting)

Heating setting temperature

SW SET3-3	SW SET3-4	Heating Stage 1 setting temperature °F (°C)	Remarks
OFF★	OFF★	86 (30)	Pattern1
OFF	ON	81 (27)	Pattern2
ON	OFF	75 (24)	Pattern3
ON	ON	70 (21)	Pattern4

(★: Factory setting)

(3)-2 Two-stage setting

Cooling setting temperature

SW SET3-2	Cooling Stage 1 setting temperature °F (°C)	Cooling Stage 2 setting temperature °F (°C)	Remarks
OFF★	68 (20)	64 (18)	Pattern1
ON	72 (22)	68 (20)	Pattern2

(★: Factory setting)

Heating setting temperature

SW SET3-3	SW SET3-4	Heating Stage 1 setting temperature °F (°C)	Heating Stage 2 setting temperature °F (°C)	Remarks
OFF★	OFF★	81 (27)	86 (30)	Pattern1
OFF	ON	77 (25)	82 (28)	Pattern2
ON	OFF	75 (23)	79 (26)	Pattern3
ON	ON	70 (21)	75 (24)	Pattern4

(★: Factory setting)

NOTES:

These are the limit temperature for cooling and heating.

Energy saving performance is improved in the order from Cooling Pattern 1 to 2 and Heating Pattern 1 to 4.

(4) Delay off setting

SW SET2-3	SW SET2-4	Delay off time
OFF★	OFF★	0 minutes
OFF	ON	5 minutes
ON	OFF	10 minutes
ON	ON	20 minutes

(★: Factory setting)

Delay OFF:

Delay OFF is the function to operate continuously after reaching to the setting temperature of thermostat.

This function may make the air conditioning efficient.

Set the Delay OFF time by SW SET 2-3 and SW SET 2-4.

(5) Fan setting (G signal)

SW SET2-1	SW SET2-2	Indoor unit airflow
OFF★	OFF★	Auto
OFF	ON	High
ON	OFF	Med.
ON	ON	Low

(★: Factory setting)

9. TURNING ON THE POWER

- (1) Check this product wiring and switch settings on the circuit board.
- (2) Check the wiring and switch settings for the VRF system or multi system or single model. For the wiring and switch settings method, refer to the installation instruction sheet of each unit.
- (3) Turn on the power for the VRF system etc.
- (4) Power will be supplied from the indoor unit to this product.
 - This product will be initialized and the power turned on. LED1 (green) and LED2 (orange) will flashing.
 - After initial setting is completed, operation will be restarted automatically. LED1 (green) lights.
 - This product does not operate during initialization.
 - * An error code will appear on LED in the event of a malfunction.

10. LED DISPLAY

10. 1. Normal code

Normal indications				Normal contents
LED1 (green)	LED2 (orange)	LED3 (red)	LED4 (blue)	
●	●	□	□	During initialization (during initialization sequence)
■	□	□	□	Normally operating

Display mode ■ : On
 □ : Off
 ● : 1s ON / 1s OFF

10. 2. Error code

Error indications				Error contents
LED1 (green)	LED2 (orange)	LED3 (red)	LED4 (blue)	
● (n)	● (n)	◇	□	Thermostat convertor error
● (n)	● (n)	◇	■	Indoor unit error

Display mode ■ : On
 □ : Off
 ● : 0.5s ON / 0.5s OFF
 ◇ : 0.1s ON / 0.1s OFF
 () : Number of flashing

11. USAGE

- For the usage and installation of thermostat controller, refer to the operating manual and installation manual of thermostat controller.