

Series 007

Double Check Valve Assembly

Sizes: 1/2" – 3"

- Installation
- Service
- Repair Kits
- Maintenance

For field testing procedure, send for IS-TK-DP/DL, IS-TK-9A, IS-TK-99E and IS-TK-99D.

For other repair kits and service parts, send for PL-RP-BPD and F-RK-DC.

For technical assistance, contact your local Watts representative on back page.

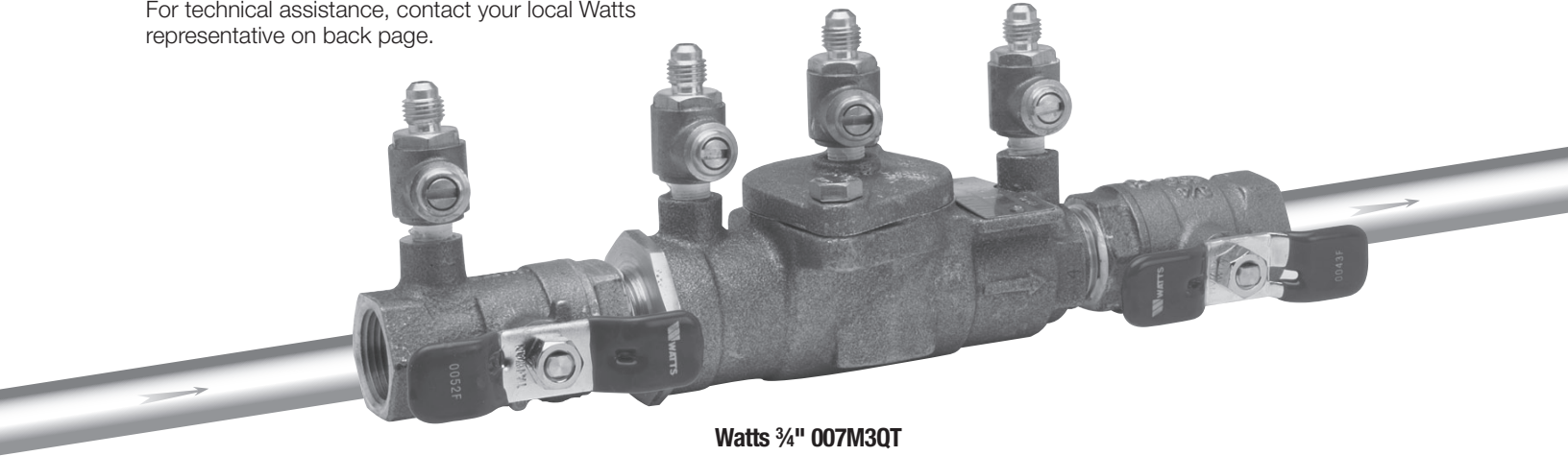

Watts 3/4" 007M3QT

IMPORTANT: Inquire with governing authorities for local installation requirements.

NOTE: For Australia and New Zealand: Pipeline strainers should be installed between the upstream shutoff valve and the inlet of the backflow preventer.

Watts product specifications in U.S. customary units and metric are approximate and are provided for reference only. For precise measurements, please contact Watts Technical Service. Watts reserves the right to change or modify product design, construction, specifications, or materials without prior notice and without incurring any obligation to make such changes and modifications on Watts products previously or subsequently sold.

CALIFORNIA PROPOSITION 65 WARNING
WARNING: This product contains chemicals known to the State of California to cause cancer and birth defects or other reproductive harm. (California law requires this warning to be given to customers in the State of California.)
 For more information: www.watts.com/prop65

Limited Warranty: Watts Regulator Co. (the "Company") warrants each product to be free from defects in material and workmanship under normal usage for a period of one year from the date of original shipment. In the event of such defects within the warranty period, the Company will, at its option, replace or recondition the product without charge.

THE WARRANTY SET FORTH HEREIN IS GIVEN EXPRESSLY AND IS THE ONLY WARRANTY GIVEN BY THE COMPANY WITH RESPECT TO THE PRODUCT. THE COMPANY MAKES NO OTHER WARRANTIES, EXPRESS OR IMPLIED. THE COMPANY HEREBY SPECIFICALLY DISCLAIMS ALL OTHER WARRANTIES, EXPRESS OR IMPLIED, INCLUDING BUT NOT LIMITED TO THE IMPLIED WARRANTIES OF MERCHANTABILITY AND FITNESS FOR A PARTICULAR PURPOSE.

The remedy described in the first paragraph of this warranty shall constitute the sole and exclusive remedy for breach of warranty, and the Company shall not be responsible for any incidental, special or consequential damages, including without limitation, lost profits or the cost of repairing or replacing other property which is damaged if this product does not work properly, other costs resulting from labor charges, delays, vandalism, negligence, fouling caused by foreign material, damage from adverse water conditions, chemical, or any other circumstances over which the Company has no control. This warranty shall be invalidated by any abuse, misuse, misapplication, improper installation or improper maintenance or alteration of the product.

Some States do not allow limitations on how long an implied warranty lasts, and some States do not allow the exclusion or limitation of incidental or consequential damages. Therefore the above limitations may not apply to you. This Limited Warranty gives you specific legal rights, and you may have other rights that vary from State to State. You should consult applicable state laws to determine your rights. **SO FAR AS IS CONSISTENT WITH APPLICABLE STATE LAW, ANY IMPLIED WARRANTIES THAT MAY NOT BE DISCLAIMED, INCLUDING THE IMPLIED WARRANTIES OF MERCHANTABILITY AND FITNESS FOR A PARTICULAR PURPOSE, ARE LIMITED IN DURATION TO ONE YEAR FROM THE DATE OF ORIGINAL SHIPMENT.**



Installation Instructions

Series 007 Double Check Valve Assemblies

Indoors - Figure 1

Check local codes for installation requirements. Pipe lines should be thoroughly flushed to remove foreign material before installing the unit. A strainer should be installed as shown, ahead of backflow preventer to prevent disc from unnecessary fouling. Install valve in the line with arrow on valve body pointing in the direction of flow.

For indoor installations, it is important that the valve be easily accessible to facilitate testing and servicing. Do not install in a concealed location.

CAUTION: Do not install with strainer when backflow preventer is used on seldom-used water lines which are called upon during emergencies, such as fire sprinkler lines, etc.

It is important that Series 007 be tested periodically in compliance with local codes, but at least once a year or more often depending upon system conditions. Regular inspection, testing and cleaning assures maximum life and proper product function.

NOTE: Fire Protection System Installations

The National Fire Protection Agency (NFPA) Guidelines require a confirming flow test to be conducted whenever a "main line" valve such as the shutoff valves or a backflow assembly have been operated. Certified testers of backflow assemblies must conduct this test. The trim valves of the confirming flow test. When the test is completed the trim valves must be returned to a fully open position.

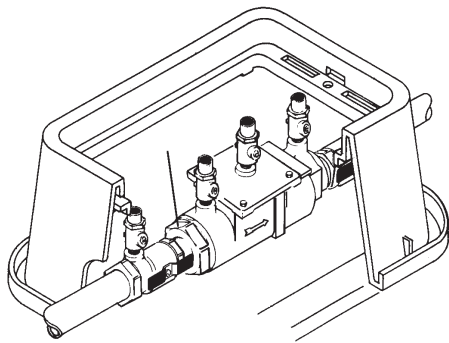

Meter Box Installation

Parallel - Figure 3

Two or more Series 007 smaller size valves may be piped in parallel (where approved) to serve a larger supply pipe main. This type of installation is employed whenever it is vital to maintain a continuous supply of water/where interruptions for testing and servicing would be unacceptable. It also has the advantage of providing increased capacity where needed beyond that provided by a single valve and permits testing or servicing of an individual valve without shutting down the complete line.

For two valve installations the total capacity of the devices should equal or exceed that required by the system.

The quantity of valves used in parallel should be determined by the engineers judgement based on the operating conditions of a specific installation.

Figure 1

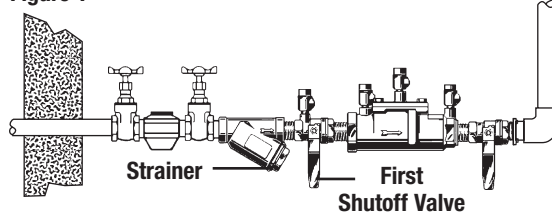

007QT-S

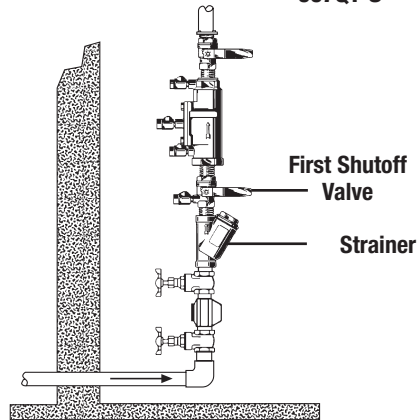

007QT-S Vertical flow-up or vertical flow-down installation (flow-up shown)

Figure 2

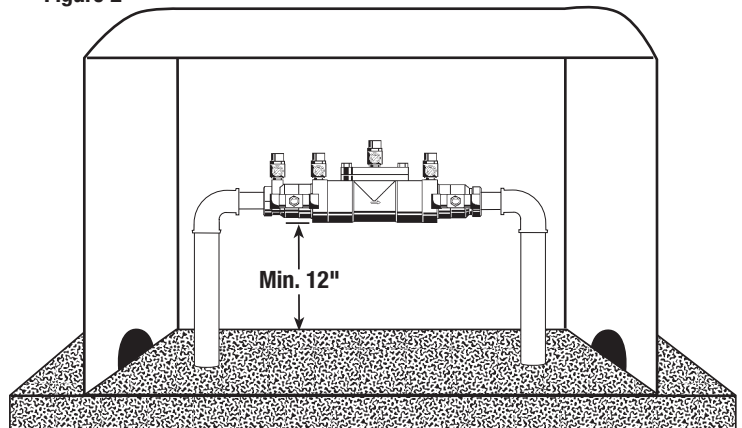

Fiberglass WattsBox
Now Available, WattsBox Insulated Enclosures.
For more information, send for ES-WB or ES-WB-T.

Figure 3

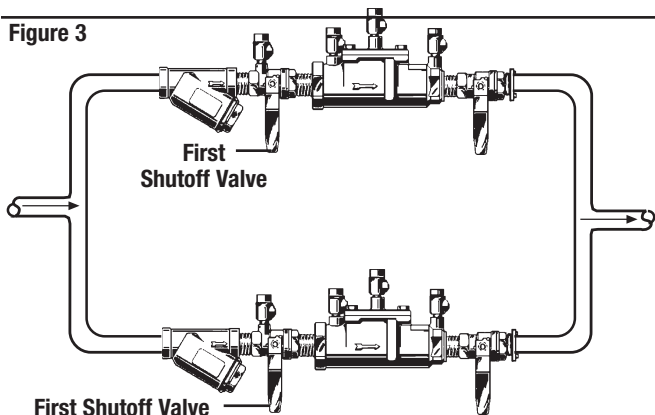

007QT-S

Service, Replacement Parts and Maintenance

Servicing the First and Second Check Valves

NOTE: Before servicing be certain water is turned off or shutoff valves are closed

1. After removing the cover, remove the retainer for the body bore. The check valve modules can now be removed from the valve by hand or with a screwdriver.

Note: For Series 007 sizes 1/2" - 2" (15-50mm), the seats and springs of the first and second check modules are not interchangeable. The heavier spring and smaller diameter seat belong with the first check module. Series 007M1 sizes 3/4" - 1" (20-25mm) and Series 007M2 3/4" (20mm) have interchangeable seats and springs.

2. The check seats are attached to the cage with a bayonet type locking arrangement. Holding the cage in one hand, push the seat inward and rotate clockwise against the cage, for 3/4" (20mm) Series 007M2 pull apart seat and cage. The seat, cage, spring and disc assembly are now individual components.

3. The disc assembly may now be cleaned and reassembled or, depending on its condition, it may be discarded and replaced with a new assembly from the repair kit. O-rings should be cleaned or replaced as necessary.

4. Reassemble the check valve module in the reverse order. Check modules are installed in the valve body with the seats facing the valve inlet. The modules must be securely in place before the retainer can be replaced. On the 3/4" - 1" (20-25mm) size, this retainer may have to be tilted slightly into place. Replace cover.

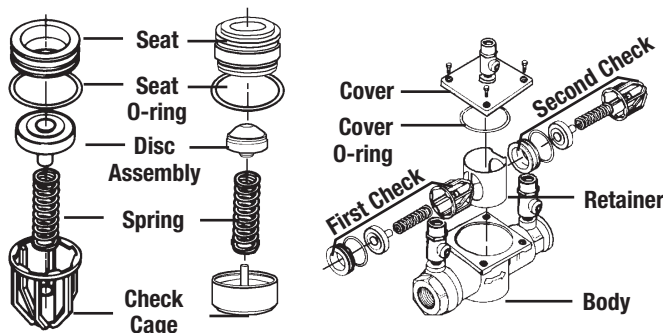
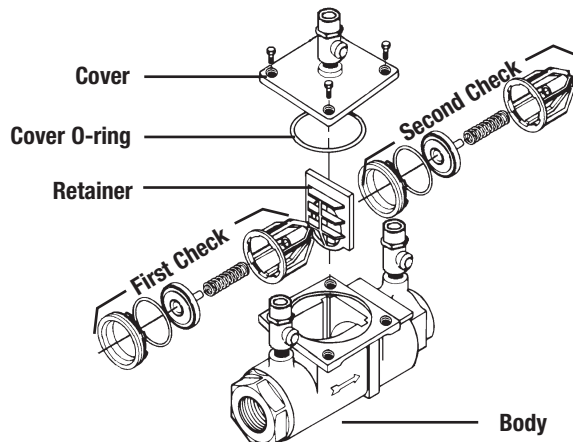
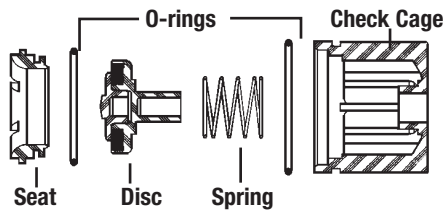

1/2" - 2" Replacement Parts

When ordering, specify ordering code number, kit number and valve size

Check Kits: 1st or 2nd Check

ORDERING CODE	KIT NO.	SIZE	
		in.	mm
0887193	RK 007 CK4	1/2	15
0887026	RK 007M1 CK4	3/4 - 1	20-25
0887377	*RK SS007 CK4	1/2	15
0888070	*RK SS007M3 CK1	1/2 - 3/4	15-20
0888071	*RK SS007M3 CK2	1/2 - 3/4	15-20
0887393	*RK SS007M2 CK1	3/4	20
0887397	*RK SS007M2 CK2	3/4	20
0887373	*RK SS007M1 CK4	1	25

1st Check

0887023	RK 007 CK1	3/4 - 1	20-25
0887045	RK 007M2 CK1	3/4	20
0888550	RK 007M3 CK1	3/4	20
0887025	RK 007 CK1	1 1/2 - 2	40-50
0887186	RK 007M1 CK1	1 1/2 - 2	40-50
0887719	RK 007M2 CK1	1 1/4 - 1 1/2	32-40

2nd Check

0887024	RK 007 CK2	3/4 - 1	20-25
0887046	RK 007M2 CK2	3/4	20
0888551	RK 007M3 CK2	3/4	20
0887028	RK 007 CK2	1 1/2 - 2	32-50
0887187	RK 007M1 CK2	1 1/2 - 2	32-50
0887720	RK 007M2 CK2	1 1/4 - 1 1/2	32-40

Stainless Steel 1st or 2nd Check

0887022	RK 007 CK1 SS	3/4 - 1	20-25
0887030	RK 007 CK2 SS	3/4 - 1	20-25
0887032	RK 007M1 CK4 SS	3/4 - 1	20-25
0887031	RK 007 CK1 SS	1 1/2 - 2	40-50
0887035	RK 007 CK2 SS	1 1/2 - 2	40-50
0887189	RK 007M1 CK1 SS	1 1/2 - 2	40-50
0887190	RK 007M1 CK2 SS	1 1/2 - 2	40-50

Kit includes: Seat, seat o-ring, disc assembly, spring, check cage, cover o-ring.

Cover Kit

0887195	RK 007 C	1/2	15
0887036	RK 007 C	3/4 - 1	20-25
0887038	RK 007M1 C	3/4 - 1	20-25
0887039	RK 007M2 C	3/4	20
0888553	RK 007M3 C	3/4	20
0887037	RK 007 C	1 1/2 - 2	40-50
0887191	RK 007M1 C	1 1/2 - 2	40-50
0887722	RK 007M2 C	1 1/4 - 1 1/2	32-40
0887379	*RK SS007 C	1/2	15
0887380	*RK SS007M2 C	3/4	20
0888073	*RK SS007M3 C	1/2 - 3/4	15-20
0887381	*RK SS007M1 C	1	25

Kit includes: Cover and cover o-ring

Complete Rubber Parts

0887194	RK 007 RT	1/2	15
0887040	RK 007 RT	3/4 - 1	20-25
0887042	RK 007M1 RT	3/4 - 1	20-25
0887043	RK 007M2 RT	3/4	20
0888552	RK 007M3 RT	3/4	20
0887041	RK 007 RT	1 1/2 - 2	40-50
0887188	RK 007M1 RT	1 1/2 - 2	40-50
0887721	RK 007M2 RT	1 1/4 - 1 1/2	32-40
0887378	*RK SS007 RT	1/2	15
0887394	*RK SS007M2 RT	3/4	20
0888072	*RK SS007M3 RT	1/2 - 3/4	15-20
0887374	*RK SS007M1 RT	1	25

Kit includes: Cover o-ring, two seat discs and two seat o-rings.

*SS prefix denotes stainless steel body.

Installation Instructions

2½" and 3" 007

Indoors - Figure 1

Series 007 may be installed in either a vertical or horizontal position. Pipe lines should be thoroughly flushed to remove foreign material before installing the unit. A strainer should be installed as shown, ahead of backflow preventer to prevent disc from unnecessary fouling. Install valve in the line with arrow on valve body pointing in the direction of flow. For indoor installations, it is important that the valve be easily accessible to facilitate testing and servicing. Do not install in a concealed location.

CAUTION: Do not install with strainer when backflow preventer is used on seldom-used water lines which are called upon during emergencies, such as fire sprinkler lines, etc. It is important that Series 007 be tested periodically in compliance with local codes, but at least once a year or more often depending upon system conditions.

NOTE: Fire Protection System Installations

The National Fire Protection Agency (NFPA) Guidelines require a confirming flow test to be conducted whenever a "main line" valve such as the shutoff valves or a backflow assembly have been operated. Certified testers of backflow assemblies must conduct this test. The trim valves of the detector meter bypass line, on assemblies so equipped, should be shutoff during the confirming flow test. When the test is completed the trim valves must be returned to a fully open position.

Outside Building Above Ground -

Figure 2

In an area where freezing conditions do not occur, Series 007 can be installed outside of a building. The most satisfactory installation is above ground and should be installed in this manner whenever possible. In an area where freezing conditions can occur, Series 007 should be installed above ground in an insulated enclosure.

Annual inspection of all water system safety and control valves is required and necessary. Regular inspection, testing and cleaning assures maximum life and proper product function.

Parallel - Figure 3

Consult Local codes for Approval

Two or more Series 007 smaller size valves may be piped in parallel (where approved) to serve a larger supply pipe main. This type of installation is employed whenever it is vital to maintain a continuous supply of water/where interruptions for testing and servicing would be unacceptable. It also has the advantage of providing increase capacity where needed beyond that provided by a single valve and permits testing or servicing of an individual valve without shutting down the complete line. For two valve installations the total capacity should equal or exceed that required by the system.

The quantity of valves used in parallel should be determined by the engineers judgement based on the operating conditions of a specific installation. (See F-FC regarding flow curves)

INSTALLATION NOTE: The flange gasket bolts for the gate valves should be retightened during installation as the bolts may have loosened due to storage and shipping.

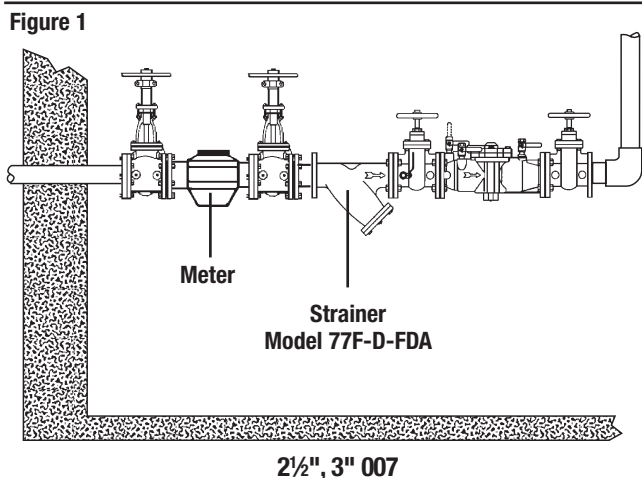
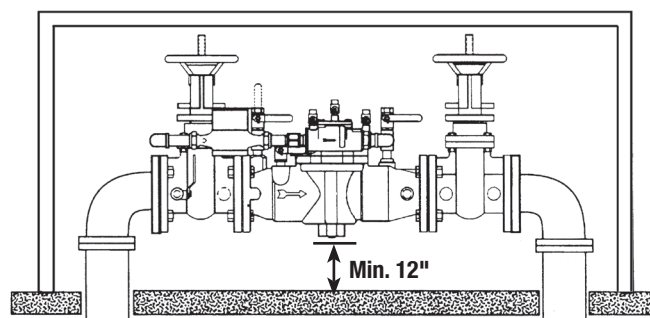
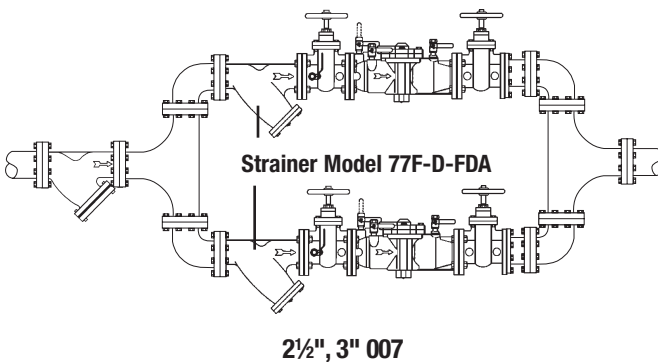

Figure 2



Now Available, WattsBox Insulated Enclosures.
For more information, send for ES-WB or ES-WB-T.

Figure 3



Servicing First and Second Check Valves

2½" and 3" 007

1. Remove cover bolts and cover.
2. Remove the retainer from the body bore. The check valve modules can now be removed from the valve by hand or with a screwdriver.
3. The check seats are attached to the cage with a bayonet type locking arrangement. Holding the cage in one hand, push the seat inward and rotate counterclock-wise against the cage. The seat, spring cage, spring and disc assembly are now individual components.
4. The disc assembly may now be cleaned and reassemble or depending on its condition, may be discarded and replaced with a new assembly from the repair kit. O-rings should be cleaned or replaced as necessary. For more information, refer to repair parts price list PL-RP-BPD.
5. Reassemble the Check valve modules. Check modules are installed in the valve body with the seats facing the valve inlet. The modules must be securely in place before the retainer can be replace.

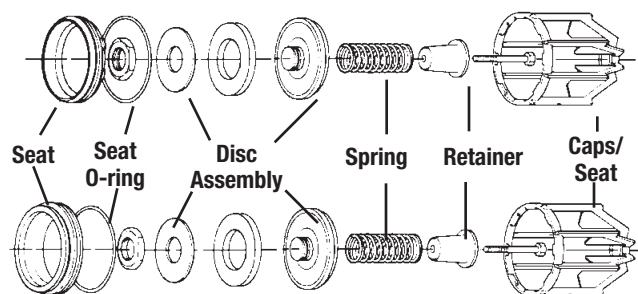

Check Assemblies

NOTE: No special tools required to service Series 007.

Replacement Parts

2½" and 3" 007

When ordering, specify ordering code number, kit number and valve size.

First Check Kit

ORDERING CODE	KIT NO.	SIZE	
		in.	mm
0887285	RK 007 CK1	2½, 3	65, 80

Kit Includes: Seat, seat o-ring, disc assembly, spring, spring retainer, check cage and cover o-ring.

Second Check Kit

0887286	RK 007 CK2	2½, 3	65, 80
---------	------------	-------	--------

Kit Includes: Seat, seat o-ring, disc assembly, spring, spring retainer, check cage and cover o-ring.

First and Second Check Rubber Parts

0887287	RK 007 RT	2½, 3	65, 80
---------	-----------	-------	--------

Kit Includes: Two seat discs, two seat o-rings, two cover o-rings.

Cover Kit

0887288	RK 007 C	2½, 3	65, 80
---------	----------	-------	--------

Kit includes: Cover and cover o-ring.

Seat Kit

0887289	RK 007 S	2½, 3	65, 80
---------	----------	-------	--------

Kit Includes: Seat and seat o-ring.

"Use only original equipment manufactured parts to protect the validated warranty."

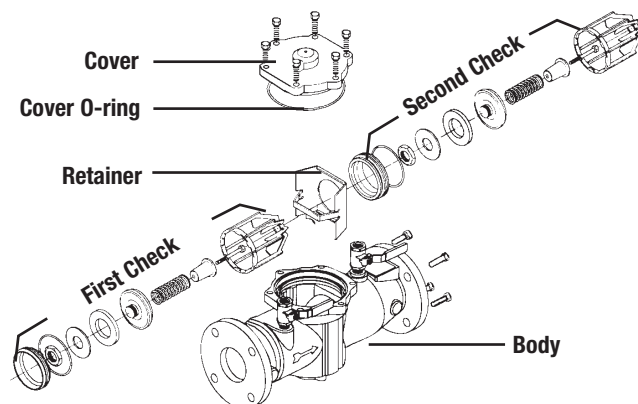

Test Procedure for Double Check Valve Assembly

- A. Before starting test, all needle valves and bleed valves on test kit must be closed.
- B. Flush test cocks before test.

NOTE: Supply pressure gauge reading will decrease when performing this test procedure.

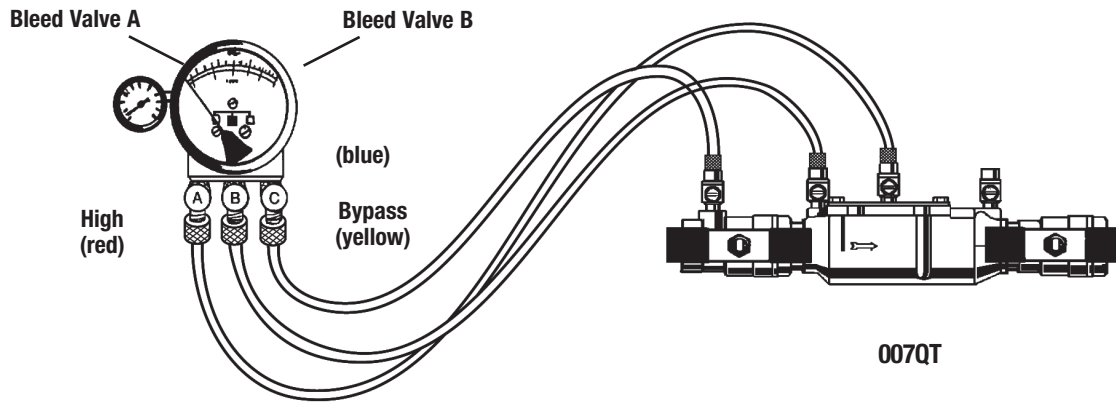

Test No. 1 - Check Valve No. 1

NOTE: Close all needle valve "A", "B" and "C" and bleed valve "A" and "B" on test kit.

- Step 1** Insure shutoff No. 1 is open, shutoff No. 2 is closed.
- Step 2** Install high side hose between connection "A" high-side and test cock No. 3, low side hose between "B" low side and test cock No. 2 and open both test cock No. 2 and 3.
- Step 3** Open bleed valve "A" to bleed air from the high side. Close "A" then open bleed valve "B" to bleed low side. Close "B."
- Step 4** Connect bypass hose between connection "C" bypass and loosely to test cock No. 1. Open needle valves "A" high side and "C" bypass to vent air from bypass hose. Tighten bypass hose at test cock No. 1, open test cock No. 1.
- Step 5** Close shutoff No. 1. Slowly open bleed "B" until differential gauge rises to 2psi and close. If the differential reading does not decrease, record check valve as "tight."
- Step 6** Close all test cocks and open bleed valves "A" and "B." Then close needle valves "A," "B" and "C" and bleed valves "A" and "B." Remove hoses from test cocks.

Test No. 2 - Check Valve No. 2

- Step 7** Move the high side hose to test cock No. 4, low side hose to test cock No. 3 and open both test cock No. 3 and 4. Remove bypass hose from test cock No. 1, open shutoff valve No. 1.

- Step 8** Open bleed valve "A" to bleed air from the high side. Close bleed "A" then open bleed "B" to bleed low side. Close bleed "B."
- Step 9** Connect bypass hose loosely to test cock No. 1. Open needle valves "A" high side and "C" bypass to vent air from the bypass hose. Tighten bypass hose at test cock No. 1, open test cock No. 1.
- Step 10** Close shutoff No. 1, then slowly open bleed "B" until differential gauge rises to 2psi and close. If the differential reading does not decrease, record check as tight. Close all test cocks and remove hoses. Open bleed valves "A" and "B." Restore valve to original working condition.

NOTE: The assembly will fail both the first and second check valve tests above, if shutoff No. 2 leaks excessively. To test for a leaky No. 2 shutoff, use the following procedure.

Test for Leaky No. 2 Shutoff

- Step 11** Connect the high side hose to test cock No. 1, low side hose to test cock No. 4. Open test cocks No. 1 and 4. Close shutoffs No.1 and 2.
- Step 12** Close needle valve "C" bypass. Open needle valve "A" high side, then open needle valve "B" low side one turn, loosen hose at test cock No. 4 to remove air. Retighten hose.
- Step 13** If the differential gauge rises above 0 there is excessive leakage at shutoff No. 2 and it must be replaced to test the assembly.

Watts Backflow Preventer Test Kits

Model TK-DL

Backflow Preventer Test Kit

TK-DL has Digital Print-Out and Computer Download
An advanced piece of test equipment designed to make pressure and differential gauges obsolete in the testing of backflow preventers.

- Accuracy
- Versatility
- Readability
- Portability
- Documentation

Test kit contains hoses, adapters, digital printout unit with complete instructions in rugged case.

For additional information, send for PG-TK.

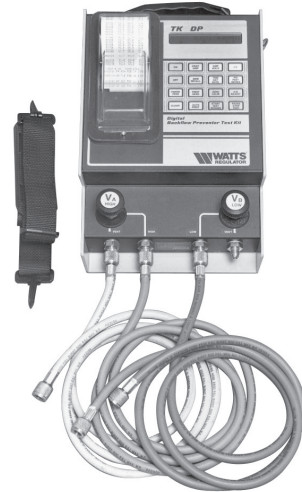

Model TK-99E

Backflow Preventer Test Kit

TK-99E has been designed for simplified operator operation and rugged reliability in a compact package. Offering the latest in gauge technology, the Watts TK-99E provides dependable accuracy when testing pressure vacuum breakers, reduced pressure backflow preventers or double check assemblies.

- A large 4.5" anti-parallax dial which indicates descending measurement, accurate to $\pm 1\%$ of full scale.
- Complete kit contains gauge with color-coded valves and hoses, hose adapters, shock cord for easy mounting, supply pressure gauge. All contained in a durable carrying case with room for tools.

For additional information, send for PG-TK.



Model TK-9A

Backflow Preventer Test Kit

Entry level test kit designed to test pressure vacuum breakers, reduced pressure backflow preventers, or double check assemblies. Accuracy to $\pm 2\%$ of full scale.

- Max. pressure 175psi.
- Max. temperature 210°F.

Test kit contains: gauge, test valves, hoses, adapters, securing strap, instruction guide and lightweight case.

For additional information, send for PG-TK.



Model TK-99D

Backflow Preventer Test Kit

Hand held digital test kit designed to test PVB's, SVB's, DCVA's, DCDA's, RP's and RPDA's

For additional information, send for PG-TK.



Model TK-7

Backflow Preventer Test Kit

Tests the individual check modules of the Watts No. 7 Residential Dual Check. Also used to test Series 709, 770 and 007 Double Check Valve Assemblies.

For additional information, send for PG-TK.



For additional information, visit our web site at: www.watts.com



A Watts Water Technologies Company



USA: 815 Chestnut St., No. Andover, MA 01845-6098; www.watts.com

Canada: 5435 North Service Rd., Burlington, ONT. L7L 5H7; www.wattscanada.ca