

Installation Instructions and Owner's Manual

FBW, FEBW, FBW-HMX & FEBW-HMX Series **Backwashing Filter Systems**



Franklin Electric Co., Inc.
Water Treatment Division

12630 US Highway 33 N
Churubusco, IN 46723
Phone (260) 693-1972 Fax (260) 693-0602

Table of Contents

Pre-installation Instructions	Page 2
Media Types	Page 2
Installation Instructions	Page 5
FBW Timer Operation	Page 9
FEBW Timer Operation	Page 11
Maintenance	Page 14
Specifications	Page 16
Component Parts Breakdown	Page 17
Component Parts List	Page 18
FBW Control Valve Breakdown	Page 19
FBW Control Valve Parts List	Page 20
FEBW Control Valve Breakdown	Page 21
FBW Control Valve Parts List	Page 22
Troubleshooting	Page 23
FBW Control Valve Wiring Diagram	Page 25
Ten Year Limited Warranty	Page 26

Pre-installation Instructions

Description of the backwashing filter

The FBW & FEBW systems include a filtration tank (with gravel and distributor) and a backwashing control valve with bypass. Filtration media for use with the FBW & FEBW systems are purchased separately and selected from the following types:

PART	MEDIA	VOLUME	PACKAGE	SHIP. WT.
NUMBER	TYPE / APPLICATION	(CU. FT.)		(LBS.)
A10	ACTIVATED CARBON TASTE & ODOR REDUCTION	1.00	BAG	29
A05P		0.50	PAIL	14
ACC10	CATALYTIC CARBON CHLORAMINE REDUCTION	1.00	BAG	29
ACC05P		0.50	PAIL	14
B10	BIRM REDUCTION OF IRON AND MANGANESE	1.00	BAG	41
B05P		0.50	PAIL	20
C05P	CALCITE SELF LIMITING ACID NEUTRALIZER	0.50	PAIL	45
FA10	FILTER – AG SUSPENDED SOLIDS REDUCTION	1.00	BAG	24
FA05P		0.50	PAIL	12
ZEO10	ZEOLITE SUSPENDED SOLIDS/ SEDIMENT REDUCTION	1.00	BAG	25
Z05P		0.50	PAIL	50
N05	NEUTRALIZER ACID NEUTRALIZER	0.50	PAIL	43
HMX10	HEAVY METALS REDUCTION REPLACEMENT MEDIA	1	BAG	50
QFS05P	QUARTZ FILTER SAND (.45mm x .55mm) SEDIMENT REDUCTION	0.50	PAIL	51

The FBW-HMX & FEBW-HMX systems include a filtration tank (with gravel and distributor), HMX10 heavy metals reduction media (shipped separately) and a backwashing control valve with bypass. The media is included with the unit for FBW-HMX & FEBW-HMX units only.

Pre-installation Instructions (cont.)

Successful Application

Any filter media may have specific limitations and/or requirements for successful application. A water sample should be submitted to Franklin Electric Co., Inc. Water Treatment Division for analysis and recommendation by Customer Service.

FBW-HMX & FEBW-HMX IMPORTANT: Contact Franklin Electric, Water Treatment Division technical services to assist with proper sizing based on the level of heavy metals in the water and the flow rate requirement. The heavy metals test results must be from a certified laboratory to ensure accuracy. Other water quality information is required as well, and will determine if pre-treatment equipment is required to meet the influent water quality pre-requisites for the FBW-HMX and FEBW-HMX systems: Iron < 0.1 ppm, Manganese < 0.01 ppm, pH < 8.0, Silica < 30 ppm, Hardness > 5 gpg is preferred but not required unless silica is present.

Once the system has been installed, a heavy metals test should be done to determine if the level(s) is(are) being reduced sufficiently (IE 10 ppb or less arsenic, 15 ppb or less lead, etc., per the EPA MCL) and should be tested regularly (every 6 months recommended) to ensure the system is functioning properly and to indicate when the media has become exhausted.

Time of Backwash

Periodically the control valve will go through a backwash cycle. This cycle is factory preset to 12:00 A.M. flushing the accumulated sediment and/or precipitant to the drain. After the backwashing process the unit is now prepared for the next period of service.

Water Supply

This filter will function properly when the water supply is furnished by a jet pump, submersible pump, variable speed (constant pressure) pump or community water supply. As with all other filter systems, however, it is imperative that the well pump provides enough flow rate for the filter to adequately backwash. In order to ensure sufficient backwash flow rate the following pumping rate test should be performed prior to installing the backwashing filter.

1. Make certain no water is being drawn in the house.
2. Open spigot nearest pressure tank.
3. When well pump starts, close spigot and measure time (in seconds) to refill pressure tank (well pump turns back off). This is **Cycle Time**.
4. Using a container of known volume, draw water from pressure tank and measure how many gallons until the pump turns back on again. This is **Draw Down**.
5. Calculate pumping rate by dividing draw down by cycle time and multiplying by 60.

$$\frac{\text{Draw Down (gallons)}}{\text{Cycle Time (seconds)}} \times 60 = \text{Pumping Rate (gallons per minute)}$$

Example: Draw down is 8 gallons
Cycle time is 65 seconds

$$\frac{8 \text{ gallons}}{65 \text{ seconds}} \times 60 = 7.4 \text{ gpm (gallons per minute)}$$

Pre-installation Instructions (cont.)

Location Considerations

The proper location to install the backwashing filter will ensure optimum filter performance and satisfactory water quality. The following factors should be considered in selecting the location of this system.

1. The backwashing filter must be installed after the pressure tank (private well system only).
2. The system should be installed as close as possible (preferably within 15') to an adequate floor or laundry drain capable of handling the backwash cycle volume and flow rate (refer to unit specifications). An air gap should be provided between the backwashing filter drain line and plumbing drain.
3. All water conditioning equipment should be installed at least 10' prior to the water heater. Water temperatures exceeding 100°F can damage the internal components of the control valve and filter tank. An expansion tank may need to be installed in the line to the water heater in order to allow for thermal expansion and comply with local plumbing codes.
4. Water pressure must not exceed the range of 25 - 100 psi.
5. The system must not be subject to freezing temperatures.
6. The control valve requires 115/120 V, 60 Hz electricity from a three prong outlet that is not wired to a switch.
7. Never install a cartridge type filter prior to the backwashing filter. Any cartridge or in-line filter (if desired) may be installed after the backwashing filter. This will prevent restricting the water flow and pressure available for backwash.
8. Appliances requiring extended periods of continuous or high flow water use (i.e. geothermal heat pumps, swimming pools, lawn irrigation, outside hose bibs, etc.) should bypass the filter.

Typical Installation

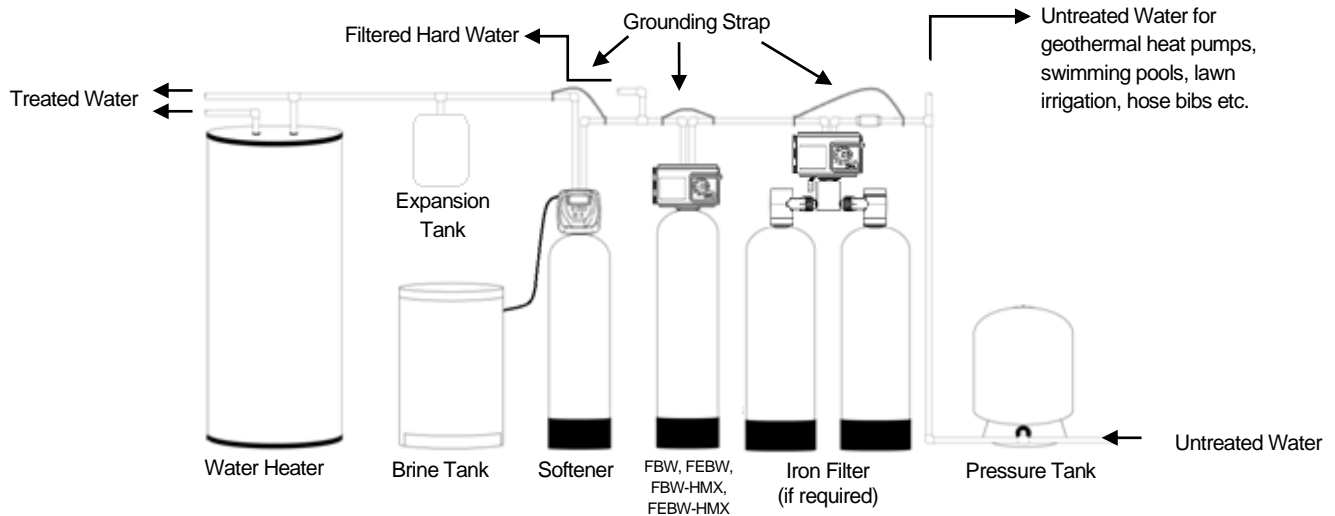

FIGURE 1: Typical Installation

Installation Instructions

- STEP 1:** Unpack the backwashing filter unit, making sure to remove entire contents of the shipping container prior to disposal.
- STEP 2:** With the backwashing filter unit in the upright position, **unscrew** the control valve from the mineral tank being **careful to not pull the distributor out of the gravel at the bottom of the tank. DO NOT REMOVE the clamp that holds the valve body to the adapter base.**
- STEP 3:** Cover the top of the distributor tube with the included red cap and, using the included blue media funnel, pour filter media(s) into the mineral tank. If using multiple filter media types, load in the order of heaviest (most dense) to lightest (least dense). 12" – 14" of space **MUST** be left empty at the top of the mineral tank to allow for media bed expansion during backwash and to prevent filter media from being discharged through the drain line.
- STEP 4:** Use a garden hose or bucket to fill the media tank with water.
- STEP 5:** Clean mineral tank threads to remove any filter media. Remove red cap from distributor tube and reinstall control valve by threading it securely onto the mineral tank. (O-ring seal; **HAND TIGHTEN ONLY!**).
- STEP 6:** Use clips and screws provided and attach bypass valve to the inlet/outlet of the control valve. See Figure 2 below.

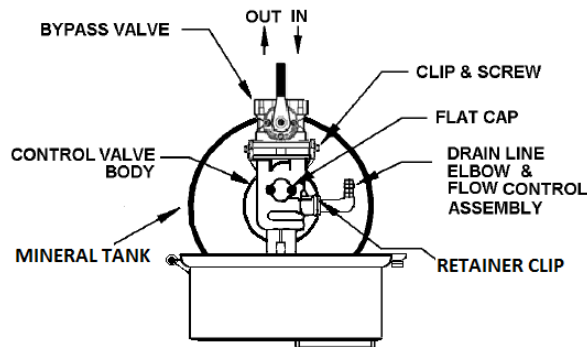

FIGURE 2: Top View of Control Valve

- STEP 7:** Shut off all water at main supply. On private well system, turn off power to pump and drain pressure tank. Make certain pressure is relieved from complete system by opening nearest faucet to drain system. **SHUT OFF FUEL / ELECTRICAL SUPPLY TO WATER HEATER.**
- STEP 8:** Cut main supply line as required to fit plumbing to inlet and outlet of bypass valve. **DO NOT PLUMB INLET AND OUTLET BACKWARDS.** Piping should be supported. Do not apply heat to any fitting attached to the bypass or control valve. Perform all plumbing according to local plumbing codes.
- STEP 9:** Attach plumbing. **DO NOT** apply heat to any fitting connected to bypass valve or control valve, as damage may result to internal parts or connecting adapters. **MAKE CERTAIN WATER ENTERS THROUGH INLET AND DISCHARGES THROUGH OUTLET.**

Installation Instructions (cont.)

- STEP 10:** Use polyethylene drain line tubing provided (**NO VINYL TUBING**) to run drain line from control valve discharge fitting to floor drain or sump pit capable of handling the backwash rate of the filter (refer to specifications and flow rate on page 12). **DISCHARGE END OF THE DRAIN LINE MUST BE FIRMLY SECURED!** There must be an air gap at the end of the drain line to prevent siphoning of waste water and meet plumbing code. Total length of drain line should be 15' or less. **AVOID OVERHEAD DRAINS.**
- STEP 11:** Place bypass in the "Bypass" position (refer to Figure 3 below). Open main supply valve or turn on power to pump on private well systems.

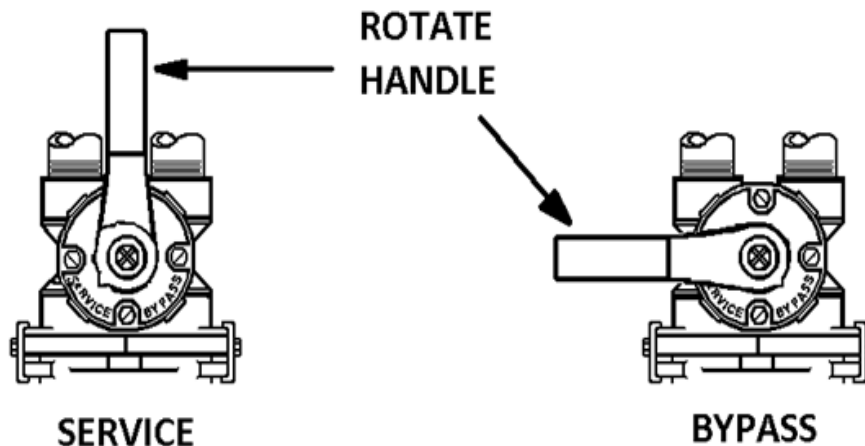

FIGURE 3: Stainless Steel Bypass Valve Operation

- STEP 12:** Plug the power cord (FBW) or transformer (FEBW) into an un-switched electrical outlet.
- STEP 13:** **FBW & FBW-HMX ONLY:** Initiate a manual regeneration by turning the Manual Backwash Knob clockwise until the knob engages the program wheel. You should hear one click and the piston should move. This is the "Backwash" position. Unplug the control valve from the electrical outlet.
- FEBW & FEBW-HMX ONLY:** Initiate a manual regeneration by holding down the middle button (ADVANCE) until the screen shows "GO TO BW". Wait for the backwash countdown timer to display on the screen and then unplug the transformer from the electrical outlet.
- STEP 14:** Refer to Figure 3 (above) for appropriate bypass valve operation. Rotate bypass lever of stainless steel bypass $\frac{1}{4}$ of the way to Service or until air and/or water begins to flow slowly to drain.
- STEP 15:** **IMPORTANT: Activated Carbon, Filter Ag and Birm must be soaked for at least 2 hours prior to submitting it to full backwash flow rate to prevent loss of media to drain.** Once the air is purged, fully open the bypass valve to the "Service" position (Figure 3 above) and leave the control valve in backwash position for at least 10 minutes or until water flowing from the drain line runs clear; whichever is longer.

Installation Instructions (cont.)

STEP 16: Plug the power cord (FBW) or transformer (FEBW) back into an un-switched electrical outlet.

FBW ONLY: advance the control valve to the “Service” position (Figure 4a, Page 9) by turning the Manual Backwash Knob clockwise.

FEBW ONLY: advance the control valve to the “Service” position (Figure 8, Page 11) by briefly pressing the middle button (ADVANCE) briefly and then repeating as each countdown timer begins, until the time of day is displayed.

ALL UNITS: Check for and resolve any leaks in the unit or connected plumbing.

STEP 17: All backwashing filters are set to backwash every 3 days. Refer to the timer operation section for your particular control valve to verify or to adjust if necessary.

IMPORTANT: Raw water quality and media type determines the frequency of backwashing required. It is recommended that the unit be backwashed **NO LESS THAN** every 6 days. If pressure drop increases or contaminants are detected in the filtered water, backwashing frequency **MUST** be increased. Filters with Calcite or Neutralizer media should be set to backwash **AT LEAST EVERY OTHER DAY** to prevent the media particles from “cementing” together.

STEP 18: **FBW ONLY:** Set the current time of day by depressing the red Time Set Button and turning the 24 Hour Gear to the desired time (note AM and PM). Refer to Figure 4a, Page 9.

FEBW ONLY: Set the current time of day by pressing the far left button (SET) and using the far right button (UP) to set the time and the middle button (ADVANCE) to move between hour, minutes and AM/PM. Refer to Figure 8, Page 11.

STEP 19: Time of Regeneration is factory set to 12:00 A.M. Refer to the timer operation section for your particular control valve to verify or to adjust if necessary

STEP 20: Turn on fuel/electrical supply to water heater.

RECOMMENDED: Retain the red distributor cap and blue media funnel for future replenishment of filter media.

NOTE: If the FBW or FEBW filter is loaded with any self-sacrificing media like Calcite or Neutralizer, mark the media level on the side of the tank by shining a bright light through the tank to see its level. Replenish the media in the mineral tank when the level drops by more than three inches.

This page intentionally left blank.

FBW Timer Operation

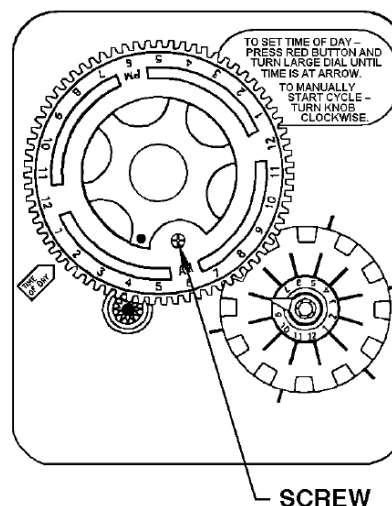
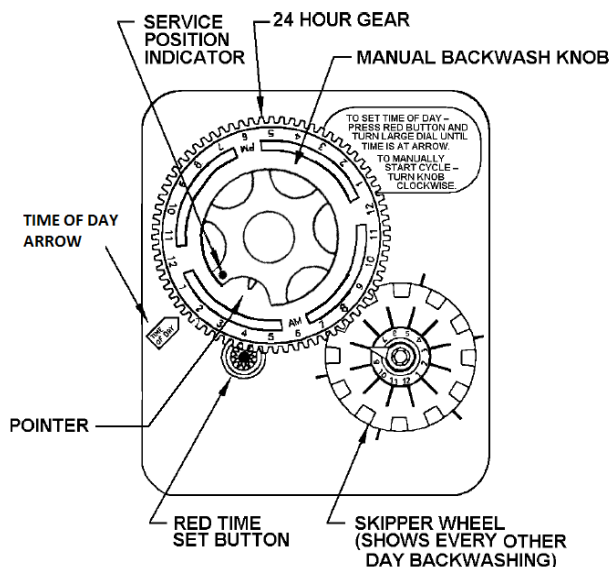

FIGURE 4a: Timer in Service Position

FIGURE 4b: Adjusting Time of Regeneration

Figure 4: Front of FBW Timer Assembly

How to set Time of Day:

1. Press and hold the red button to disengage the drive gear.
2. Turn the large 24 hour gear until the actual time of day is at the time of day pointer.
3. Release the red button to again engage the drive gear.

How to set the Days of Backwash:

1. Rotate the skipper wheel until the number 1 is at the red pointer.
2. Each number represents a day. The number by the red pointer is tonight.
3. Slide the metal tabs outward on the desired days of regeneration.

How to Manually Initiate a Backwash Cycle:

1. Grab the manual regeneration knob and turn clockwise.
2. The drive gear will engage the program wheel and make a complete revolution through the backwash cycle.
3. The backwash knob will make a complete revolution and return to the home position after the backwash cycle.

How to Set the Time of Regeneration:

1. Unplug control valve from electrical outlet.
2. Locate three screws (Fig. 4b) behind the Manual Backwash Knob by pushing the red Time Set Button (Fig. 4a) and rotating the 24 Hour Gear (Fig. 4a) until each screw appears in the cut out of the Manual Backwash Knob.
3. Loosen each screw slightly to release pressure on the time plate of the 24 Hour Gear.
4. Continue depressing the red Time Set Button and rotate the 24 Hour Gear to expose the Regeneration Time Pointer (Fig. 4a) in the cut out of the Manual Backwash Knob. Keep the Regeneration Time Pointer visible in the cut out while rotating only the time plate until the desired time (note AM or PM) is aligned with the Regeneration Time Pointer.
5. Continue depressing the red Time Set Button while rotating the 24 Hour Gear and Time Plate together to re-expose the screws in the cut out and re-tighten them. DO NOT OVERTIGHTEN. DO NOT OVERLAP REGENERATION TIME WITH ANY OTHER WATER TREATMENT EQUIPMENT.

FBW Timer Operation (cont.)

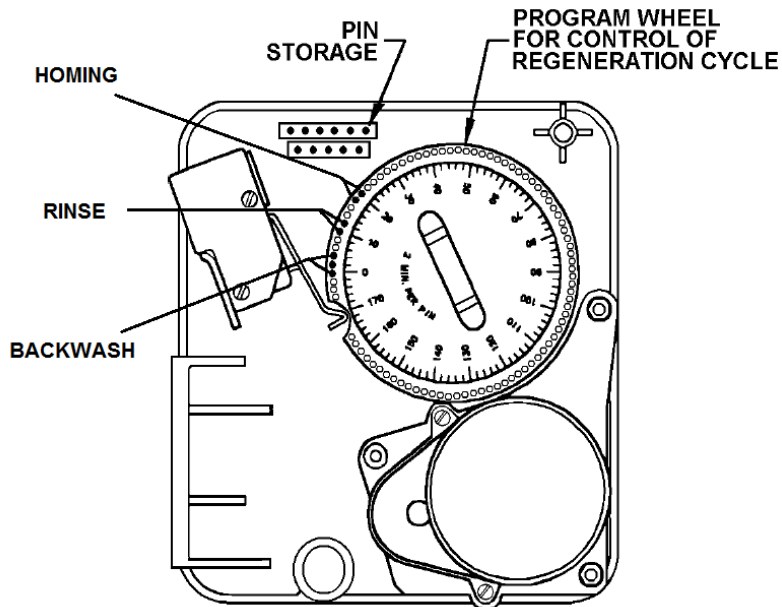

ALWAYS LEAVE 2 HOLES BETWEEN SETS OF PINS!

FIGURE 7: Back of Timer Assembly

How to Change the Length of Backwash Cycles:

All cycles have been factory set and should not need adjustment. If local conditions require different cycle lengths, however, the following procedures should be followed.

1. Grasp top left corner of timer assembly and pull to swing timer open and expose the program wheel.
2. Remove program wheel from timer by squeezing retaining lugs in center of program wheel. Maneuver program wheel away from micro switch arms and timer assembly.
3. BACKWASH cycle may be lengthened by adding pins to 1st set of pins on program wheel. Each pin will equal 2 minutes of backwash time. **The remaining two sets of pins MUST also be shifted clockwise to ensure 2 holes separate each cycle.**
4. RAPID RINSE cycle may be lengthened by adding pins to the 2nd set of pins on the program wheel. Each pin represents 2 minutes of rapid rinse time. **The last set of pins MUST also be shifted clockwise to ensure 2 holes separate each cycle.**
5. Reinstall the program wheel on the retaining lugs by maneuvering past the micro switch arms.
6. Close and latch the timer assembly. Ensure that the retainer snaps into the hole in the back plate and all electrical wiring is ABOVE the timer post.

FEBW Display and Operation

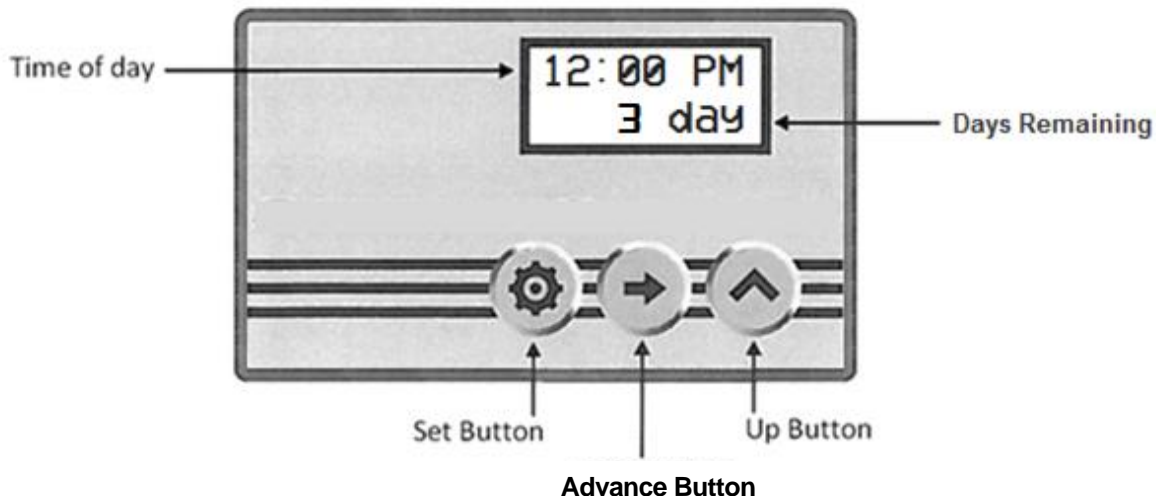

FIGURE 8: FEBW Display Panel



SET BUTTON

1. Press and hold "Set Button" for 5 seconds to enter Programming Mode.
2. When valve is in Programming Mode, press "Set Button" to confirm setting and advance to next menu option.



ADVANCE BUTTON

1. Press and hold "Advance Button" for 5 seconds to initiate an immediate regeneration cycle.
2. Press and release "Advance Button" during a regeneration cycle to immediately advance the valve to the next step in the regeneration process.
3. When the valve is in Programming Mode, press the "Advance Button" to move the cursor.



UP BUTTON

1. When the valve is in the Programming Mode, press "Up Button" to adjust setting.

FEBW Setting Time of Day

Enter Programming Mode:

Press and Hold the SET Button for 5 seconds.

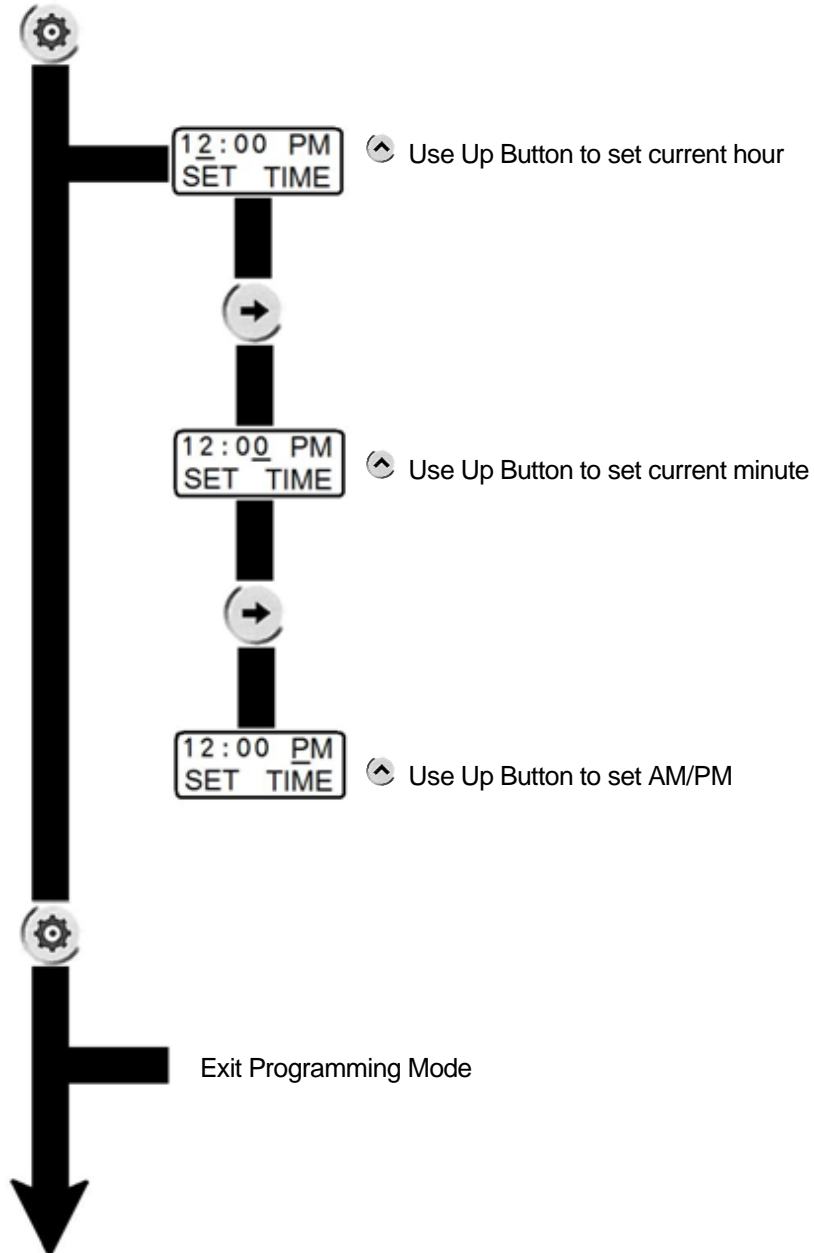

FEBW Programming

Press and HOLD the UP button for 5 seconds to enter the programming mode.

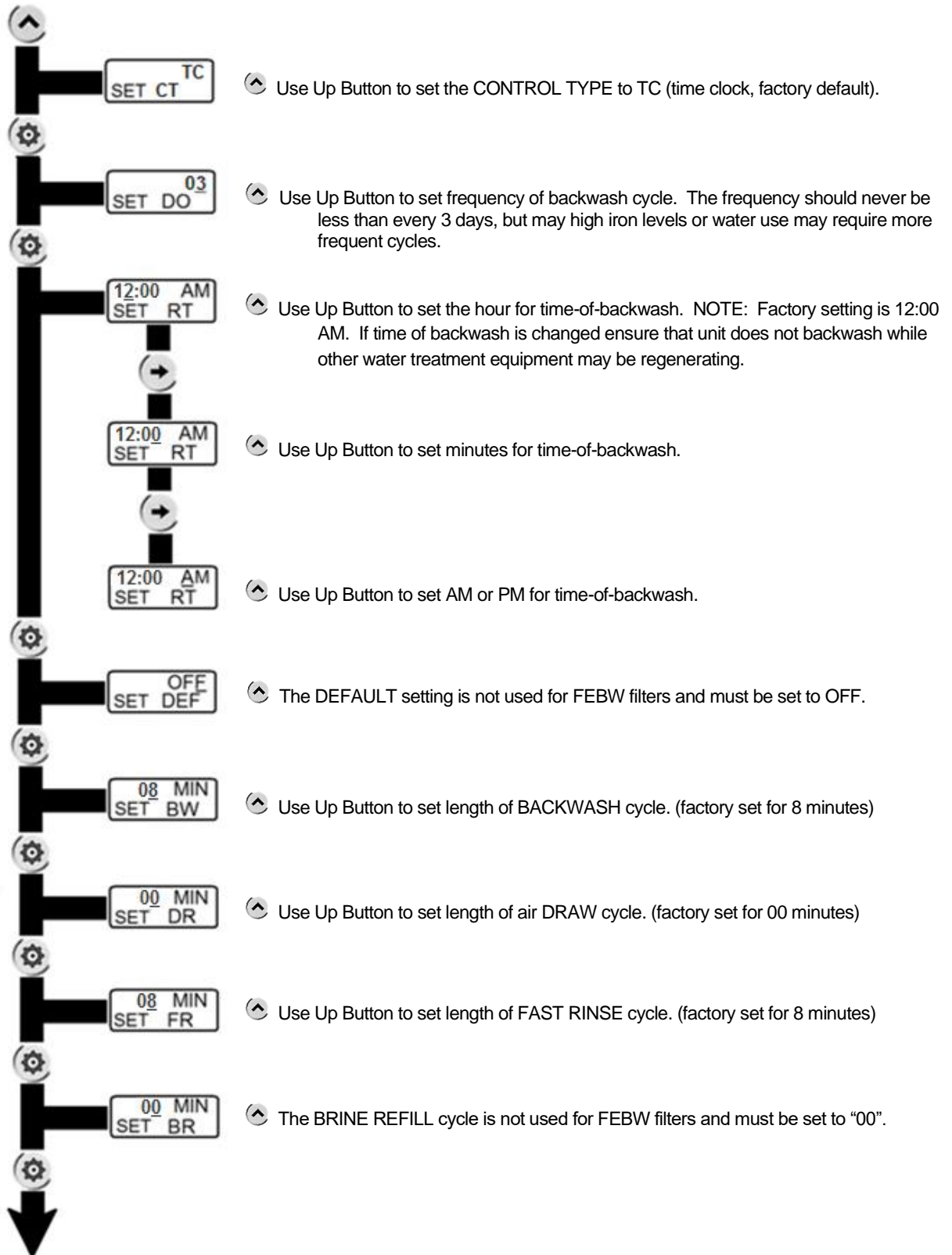

Maintenance

- 1) **FBW:** At least every six months you should check the time of day setting. Power outages will cause the units time clock to be inaccurate and backwashing will not occur at the planned time.
- 2) If your unit contains activated carbon, you must replace the carbon and gravel underbed at least every three years. Replacement may be required sooner if the taste and odor being removed begins to reappear in the treated water or you experience increasing pressure drop that is not resolved by increasing the frequency of backwashing.
- 3) Filter Ag and Filter Sand will last indefinitely. It may be necessary to replace them if you experience increasing pressure drop that is not resolved by increasing the frequency of backwashing or if water quality diminishes due to contaminant bleed through.
- 4) Neutralizer media or calcite must be replenished at least annually. Mark the side of the mineral tank at installation so the drop in media level may be monitored by shining a bright light behind the mineral tank. Add media if the level has dropped by more than three inches.
- 5) Birm should be replaced when iron reappears in the treated water and backwashing does not improve the water quality.
- 6) For the FBW-HMX or FEBW-HMX test the treated water for heavy metals every 6 months to ensure the system is functioning properly and to identify when the heavy metals reduction media has become exhausted. Satisfactory test results will be the EPA MCL or less (IE 10 ppb arsenic, 15 ppb lead, etc.). If unsatisfactory the filter will need to be re-bedded.

TO REPLENISH OR REBED MEDIA:

- 1) Pressure must be relieved on the system by placing the bypass valve in the "Bypass" position (Figure 3, Page 6) and initiating a manual regeneration and advancing to the "Backwash" position to relieve pressure. Once water has stopped flowing to drain move on to next step.
- 2) Unplug the control valve from the electrical outlet to prevent it from advancing automatically.
- 3) Disconnect the control Valve from the bypass valve
- 4) Disconnect the drain line from the control valve
- 5) Unscrew control valve from mineral tank **(IF REBEDDING ONLY - remove the distributor).**
- 6) Siphon water from mineral tank **(IF REBEDDING ONLY - Remove existing media and gravel).**
- 7) **IF REBEDDING ONLY - Rinse mineral tank and replace distributor, making certain that the distributor basket sits in the center of the tank bottom.**
- 8) Cover the top of the distributor tube to prevent media entering the tube during filling. Using a funnel, pour filter media(s) into the mineral tank. **(IF REBEDDING ONLY - Begin loading tank with the gravel underbed. Filling the mineral tank 1/3 with water before loading gravel will cushion the fall and ensure even distribution of the gravel and media. If using multiple filter media types, load in the order of heaviest {most dense} to lightest {least dense}.)** 12" – 14" of space MUST be left empty at the top of the mineral tank to allow for media bed expansion during backwash and to prevent filter media from being discharged through the drain line.

Maintenance (cont.)

- 9) Use a garden hose or bucket to fill the media tank with water.
- 10) Clean mineral tank threads to remove any filter media. Uncover distributor tube and reinstall control valve by threading it securely onto the mineral tank. (O-ring seal: HAND TIGHTEN ONLY!)
- 11) Attach bypass (Figure 2, Page 5 & Figure 3 Page 6) to control valve body.
- 12) Re-attach drain line to control valve.
- 13) **IMPORTANT: Activated Carbon, Filter Ag and Birm must be soaked for at least 2 hours prior to submitting it to full flow rate to prevent loss of media to drain.**
- 14) Open the bypass valve only 1/4 of the way to the "Service" position (Figure 3, Page 6). Any air trapped in the media bed should begin purging to the drain and water should begin flowing slowly to the drain.
- 15) Once the air is purged, fully open the bypass valve to the "Service" position (Figure 3, Page 6) and leave the control valve in "Backwash" position for at least 10 minutes or until water flowing from the drain line runs clear; whichever is longer.
- 16) Plug the power cord back into an un-switched electrical outlet.
- 17) Manually advance the control valve to the "Service" position (Figure 4a, Page 9). Check for and resolve any leaks in the unit or connected plumbing.

Specifications

Description	FBW10 FEBW10	FBW15 FEBW15	FBW20 FEBW20	FBW25 FEBW25	FBW30 FEBW30	FBW40 FEBW40
Filter Media Volume, cu. ft.	1.0	1.5	2.0	2.5	3.0	4.0
Gravel Underbed, lbs.	20	20	25	25	50	50
Operating Flow Rate, gpm						
Continuous (no duration limit, 5 gpm/ft ²)	2	3	4	5	5	7
Service (intermittent flow up to 10 gpm/ft ²)	5	6	8	9	11	14
Peak (10 mins. or less, 15 gpm/ft ²)	8	9	12	14	16	21
Backwash Flow Rate, gpm	5	5	7	7	10	10
Service Pipe Size, in.						
Standard	¾	¾	¾	¾	¾	¾
-1 Suffix on Model Number	1	1	1	1	1	1
Tank Diameter x Height, in.	10 x 44	10 x 54	12 x 48	13 x 54	14 x 65	16 x 65
Minimum Space Required, in.						
Width	12	12	13	14	15	17
Depth	15	15	15	15	15	17
Height	54	64	58	64	75	75
Approximate Ship Wt., lbs. (Media Not Included)	49	52	60	75	99	115

Description	FBW10HMX FEBW10HMX	FBW20HMX FEBW20HMX	FBW30HMX FEBW30HMX	FBW40HMX FEBW40HMX
Filter Media Volume, cu. ft.	1.0	2.0	3.0	4.0
Gravel Underbed, lbs.	20	25	50	50
Operating Flow Rate, gpm				
Service (10 gpm/ft ² media surface)	5	8	11	14
Peak (<=15 psi loss)	11	12	13	14
Exceeding peak flow can damage the media!				
Backwash Flow Rate, gpm	5	7	9	10
Pressure Loss, psi				
@ Service	5	8	11	15
@ Peak	14	14	14	15
Service Pipe Size, in.				
Standard	¾	¾	1	1
-1 Suffix on Model Number	1	1	-NA-	-NA-
Tank Diameter x Height, in.	10 x 44	12 x 48	14 x 65	16 x 65
Minimum Space Required, in.				
Width	12	13	15	16
Depth	15	16	17	18
Height	54	58	75	75
Approximate Ship Wt., lbs.	112	168	287	343

Component Parts Breakdown

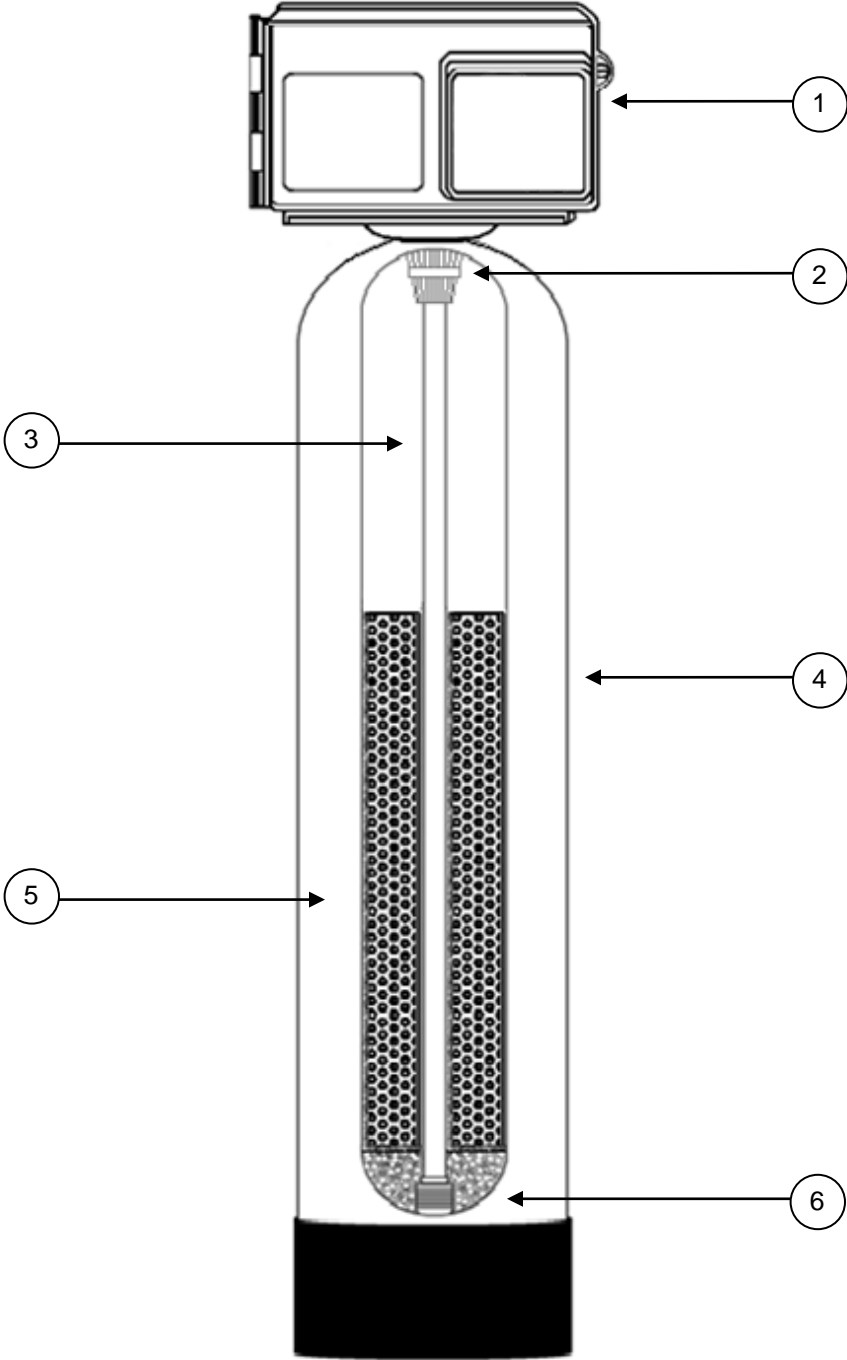

Component Parts List

Ref #	Part Number	Description
1	FBW10 Vlv Assy L/BP	Control Valve, Cover, 5.0 GPM DLFC, less bypass for models FBW10, FBW15, & FBW10HMX
	FEBW10 Vlv Assy L/BP	Control Valve, Cover, 5.0 GPM DLFC, less bypass for models FEBW10, FEBW15, & FEBW10HMX
	FBW20 Vlv Assy L/BP	Control Valve, Cover, 7.0 GPM DLFC, less bypass for model FBW20, FBW25, & FBW20HMX
	FEBW20 Vlv Assy L/BP	Control Valve, Cover, 7.0 GPM DLFC, less bypass for model FEBW20, FEBW25, & FEBW20HMX
	FBW30 Vlv Assy L/BP	Control Valve, Cover, Blank DLFC, less bypass for model FBW30, FBW40, FBW30HMX, & FBW40HMX
	FEBW30 Vlv Assy L/BP	Control Valve, Cover, Blank DLFC, less bypass for model FEBW30, FEBW40, FBW30HMX, & FEBW40HMX
2	18280-02	Top Screen, Bayonet Style
3	D100S-48	Distributor Tube, 1" x 48" for models FBW10, FEBW10, FBW20, FEBW20, FBW10HMX, FEBW10HMX, FBW20HMX & FEBW20HMX
	D100S-54	Distributor Tube, 1" x 54" for model FBW15, FEBW15, FBW25, FEBW25
	D100S-65	Distributor Tube, 1" x 65" for model FBW30, FEBW30, FBW40, FEBW40, FBW30HMX, FEBW30HMX, FBW40HMX & FEBW40HMX
4	MTP1044N	10 x 44 Mineral Tank, Nat, Base, 2.5" Top Opening For model FBW10, FEBW10, FBW10HMX, FEBW10HMX
	MTP1054N	10 x 54 Mineral Tank, Nat, Base, 2.5" Top Opening For model FBW15, FEBW15
	MTP1248N	12 x 48 Mineral Tank, Nat, Base, 2.5" Top Opening For model FBW20, FEBW20, FBW20HMX & FEBW20HMX
	MTP1354N	13 x 54 Mineral Tank, Nat, Base, 2.5" Top Opening For model FBW25 & FEBW25
	MTP1465N	14 x 65 Mineral Tank, Nat, Base, 2.5" Top Opening For model FBW30, FEBW30, FBW30HMX & FEBW30HMX
	MTP1665N-4.0	16 x 65 Mineral Tank, Nat, Base, 4.0" Top Opening For model FBW40, FEBW40, FBW40HMX & FEBW40HMX (SF4821-2 4x2.5 bushing also required)
5*	MEDIA: Refer to media list on page 2 and specification on page 16 to determine the type and quantity of media required.	
6**	QC20	1/4" x 1/8" Gravel, 20 lb Pail for models FBW10, FEBW10, FBW15, FEBW15, FBW10HMX & FEBW10HMX
	Qty ½ - QC50	1/4" x 1/8" Gravel, 25 lb Pail For models FBW20, FEBW20, FBW25, FEBW25, FBW20HMX, FEBW20HMX
	QC50	1/4" x 1/8" Gravel, 50 lb Bag For models FBW30, FEBW30, FBW40, FEBW40, FBW30HMX, FEBW30HMX, FBW40HMX & FEBW40HMX

*Filter media sold separately. Select appropriate media for water condition (page 2).

**Gravel included with the backwashing filter.

FBW Control Valve Breakdown

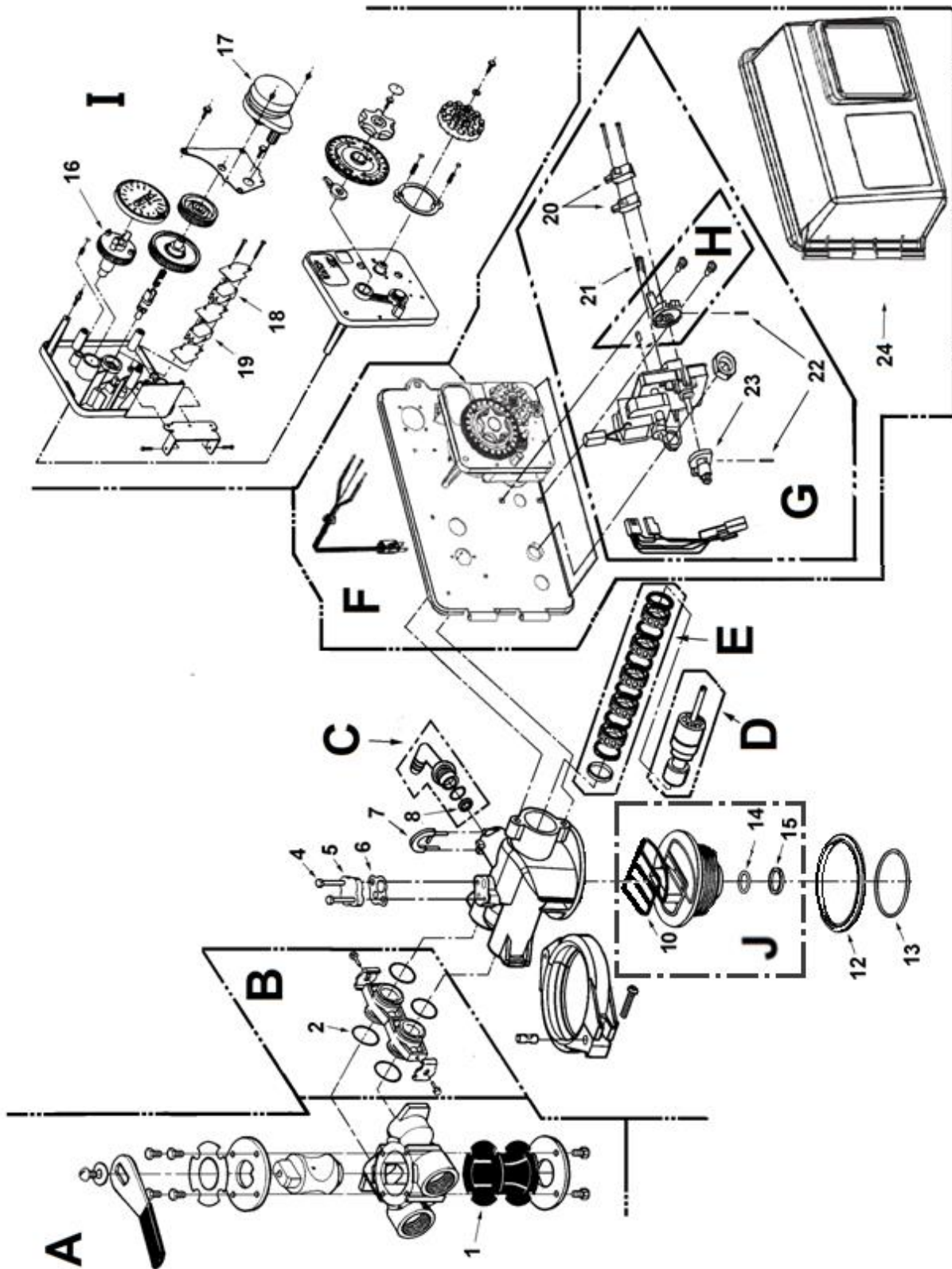

FBW Control Valve Parts List

REF #	Part Number	Description
A	60040SS	Stainless Steel Bypass, 3/4" FPT (Standard)
	60041SS	Stainless Steel Bypass, 1" FPT
B	60900-41	Coupling Kit
Not Shown	60705-50	5.0 gpm DLFC Housing (Old Style for 1 & 1.5 cu ft)
	60705-70	7.0 gpm DLFC Housing (Old Style for 2 & 2.5 cu ft)
	60705-00	Blank DLFC Housing (Old Style for 3 & 4 cu ft)
C	60705-50A	5.0 gpm DLFC Elbow (New Style for 1 & 1.5 cu ft)
	60705-70A	7.0 gpm DLFC Elbow (New Style for 2 & 2.5 cu ft)
	60705-00A	Blank DLFC Elbow (New Style for 3 & 4 cu ft)
D	60090	Piston Assembly
E	60121	Seal and Spacer Kit
F	FV2510-1PH	Power Head Assembly, 2510 TC with Cover
G	60050-21	Drive Motor Assembly
H	60160-10	Drive Cam Assembly, STF
I	60304-13	Timer Assembly, 3200, 12 Day, STF, 120/60
J	19322	Adapter Base w/ REF #'s 10, 14 & 15
1	14105	Bypass Valve Seal, Single Lever
2	13305	Coupling O-Ring, -019
4	10692	Injector cover screw
5	11893	Injector Cover
6	14805	Injector Body Gasket

REF #	Part Number	Description
7	18312	Retainer Clip, Drain
8	12092	5.0 gpm DLFC (For 1 & 1.5 cu ft)
	12408	7.0 gpm DLFC (For 2 & 2.5 cu ft)
	-NA-	No DLFC used (For 3 & 4 cu ft)
Not Shown	12338	Drain Fitting, Hose Barb, 90 Deg Elbow, 1/2" x 1/2" (Old Style)
10	19936	Base Seal (2510)
12	19197	Slip Ring
13	18303	Tank O-Ring, 2510 Valve
14	13304	Distributor O-Ring, -121
15	13030	Distributor Retainer
16	13911	Main Drive Gear
17	18743-1	Timer Motor, 120v/60Hz, 2510/5600 Valve
18	15320	Micro Switch, Homing
19	10896	Micro Switch, Step
20	10218	Micro Switch, Drive Motor
21	10909	Connecting Link Pin
22	10338	Roll Pin
23	12777	Brine Cam, STF
24	60219-02	Valve Cover, Environmental (Old Style)
	SCA-925	Valve Cover, Environmental (New Style)

FEBW Control Valve Breakdown

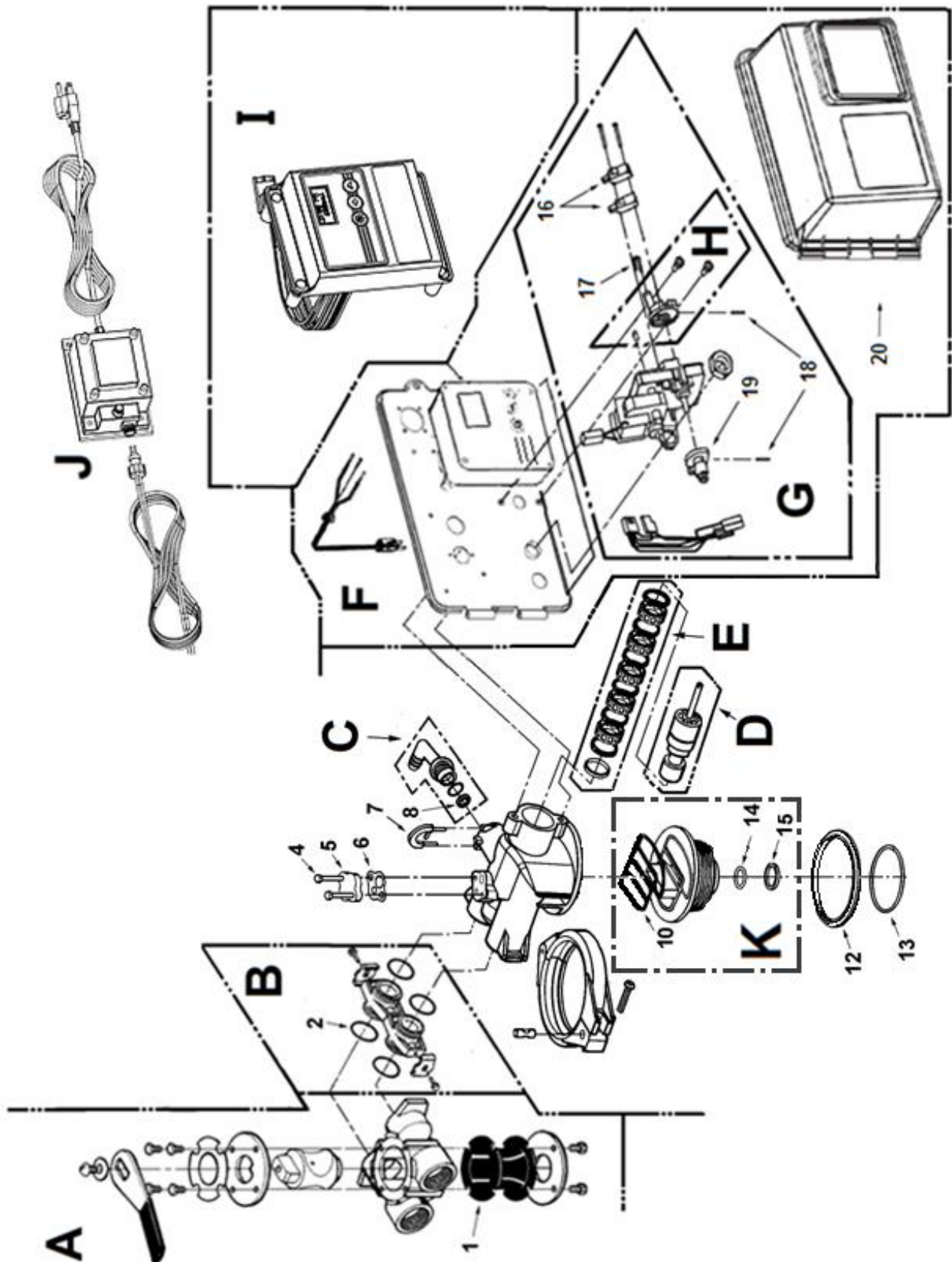

FEB Control Valve Parts List

REF #	Part Number	Description
A	60041SS	Stainless Steel Bypass, 1" FPT
	60040SS	Stainless Steel Bypass, ¾" FPT
B	60900-41	Coupling Kit
C	60705-50A	5.0 gpm DLFC Elbow (For 1 & 1.5 cu ft)
	60705-70A	7.0 gpm DLFC Elbow (For 2 & 2.5 cu ft)
	60705-00A	Blank DLFC Elbow (For 3 & 4 cu ft)
D	60090	Piston Assembly
E	60121	Seal and Spacer Kit
F	FV2510E-1PH	Power Head Assembly, 2510E with Cover
G	60050-23	Drive Motor Assembly
H	60160-10	Drive Cam Assembly, STF
I	60308-13	2510E Timer Assembly
J	FE-TRANS	Transformer
K	19322	Adapter Base w/ REF #'s 10, 14 & 15
1	14105	Bypass Valve Seal, Single Lever
2	13305	Coupling O-Ring, -019
4	10692	Injector cover screw 2510 valve

REF #	Part Number	Description
5	11893	Injector Cover
6	14805	Injector Body Gasket
7	18312	Retainer Clip, Drain
8	12092	5.0 gpm DLFC (For 1 & 1.5 cu ft)
	12408	7.0 gpm DLFC (For 2 & 2.5 cu ft)
	-NA-	No DLFC used (For 3 & 4 cu ft)
9	11183	DLFC retainer O-ring
10	19936	Base Seal (2510)
12	19197	Slip Ring
13	18303	Tank O-Ring, 2510 Valve
14	13304	Distributor O-Ring, -121
15	13030	Distributor Retainer
16	10218	Micro Switch, Drive Motor
17	10909	Connecting Link Pin
18	10338	Roll Pin
19	12777	Brine Cam, STF
20	SCA-925	Environmental Cover

Troubleshooting

PROBLEM	CAUSES	SOLUTIONS
Excessive pressure drop through filter	<ul style="list-style-type: none"> A) Filter not backwashing B) Filter bed loaded with sand C) "Cementing" or "Channeling" D) Drain line restricted E) Top Screen Fouled F) Control Valve plugged with debris 	<ul style="list-style-type: none"> 1) Check timer motor and replace if faulty 2) Ensure uninterrupted power supply 3) Check Backwash frequency setup 4) Verify sediment being removed is less dense than the filter media and install a "Spin-Down" type sediment filter ahead of the filter to remove well sand 5) Verify adequate pumping rate for backwash 6) Probe media bed to check for "Cementing" 7) Check drain line for restriction: frozen, plugged, kinked, exceeds 15', overhead installation, flexible drain line, drain line diameter too small 8) Remove and clean top screen 9) Disassemble and clean control valve
Contaminant not being properly removed	<ul style="list-style-type: none"> A) Leaking bypass valve B) Internal valve leak C) Distributor not seated properly in control valve D) Water usage flow rate exceeds filter specifications 	<ul style="list-style-type: none"> 1) Verify bypass valve is in service position 2) Replace piston, spacers and seals 3) Verify distributor tube seated securely in control valve body 4) Verify actual water usage flow rates against system specifications 5) Increase length of backwash and rinse cycles
Neutralizer media raises pH too high	<ul style="list-style-type: none"> A) Filter is brand new B) Wrong media used 	<ul style="list-style-type: none"> 1) Turn bypass valve very slightly to the "Bypass" position allowing a small amount of untreated water to bleed into the treated water 2) Rebed the unit with a less aggressive media
Neutralizer media fails to raise pH sufficiently	<ul style="list-style-type: none"> A) Water usage flow rate is too high to provide adequate contact time B) Media bed is "Cemented" or "Channeled" 	<ul style="list-style-type: none"> 1) Verify actual water usage flow rates against system specifications 2) Verify adequate pumping rate for backwash 3) Check drain line for restriction: frozen, plugged, kinked, exceeds 15', overhead installation, flexible drain line, drain line diameter too small
Birm Filter fails to remove iron	<ul style="list-style-type: none"> A) pH too low B) Dissolved oxygen level too low 	<ul style="list-style-type: none"> 1) pH of untreated water must be 6.8 or higher – adjust with proper equipment 2) Aerator may be installed prior to the filter
Loss of media to drain	<ul style="list-style-type: none"> A) Air in system B) Insufficient soak time before first backwash after installing media 	<ul style="list-style-type: none"> 1) Ensure well system has proper air elimination control 2) Check media level and adjust if necessary
Howling or whistling noise during regeneration	<ul style="list-style-type: none"> A) Inadequate drain line diameter or drain line restricted 	<ul style="list-style-type: none"> 1) Reconfigure or replace drain line

Troubleshooting

PROBLEM	CAUSES	SOLUTIONS
Control Valve cycles continually	A) Faulty switch B) Faulty timer	1) Replace faulty switch 2) Replace faulty timer
Continuous flow of water to drain	A) Loss of electrical power during regeneration B) Program wheel setup incorrectly C) Debris in control valve D) Internal leak in control valve E) Drive motor faulty	1) Ensure electrical outlet is functioning 2) Verify timer programming 3) Disassemble and clean control valve 4) Replace seals and/or piston 5) Replace faulty drive motor
Media in the service lines	A) Unit installed backwards	1) Re-plumb the water lines so that the supply side of the line is connected to the inlet of the bypass and the service side is connected to the outlet.

FBW Control Valve Wiring Diagram

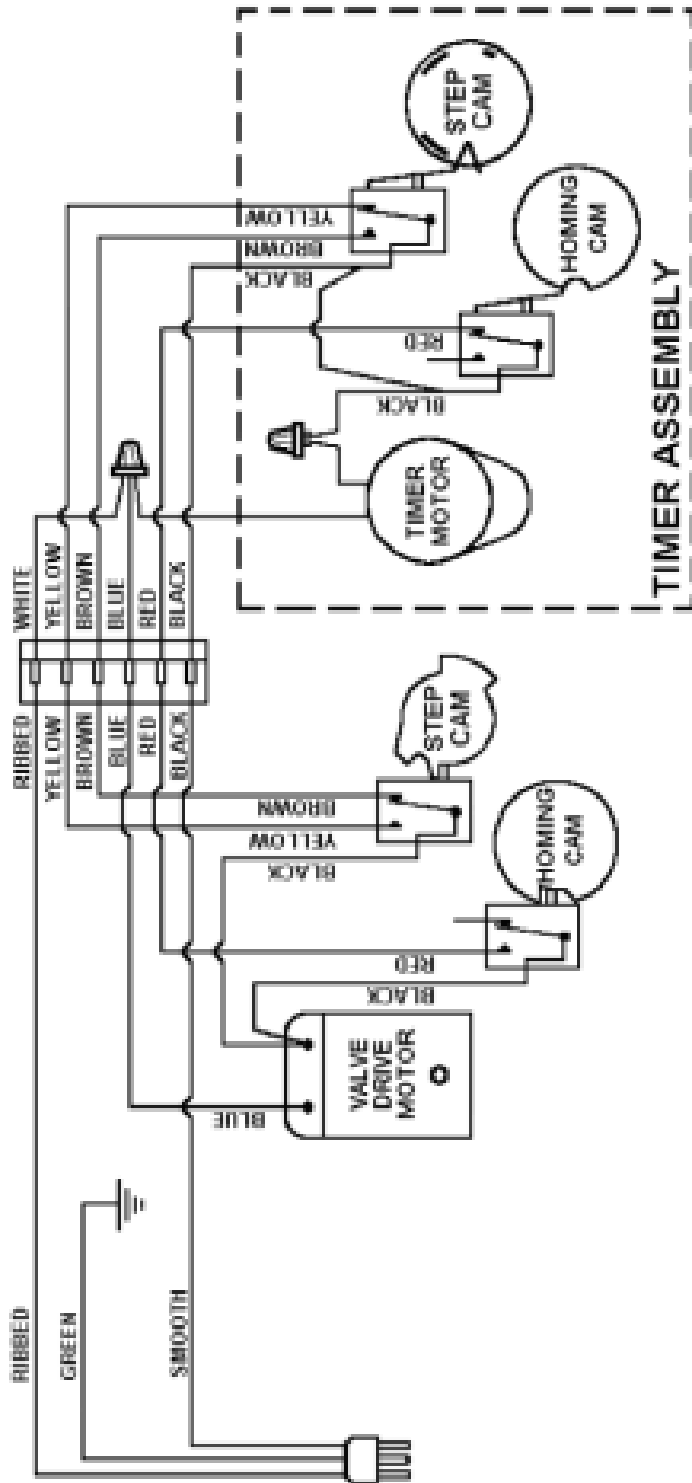

TEN YEAR LIMITED WARRANTY

WARRANTY – Franklin Electric Co., Inc. warrants this water conditioner against any defects that are due to faulty material or workmanship during the warranty period. This warranty does not include damage to the product resulting from accident, neglect, misuse, misapplication, alteration, installation or operation contrary to printed instructions, or damage caused by freezing, fire, flood, or Acts of God. From the original date of consumer purchase, we will repair or replace, at our discretion, any part found to be defective within the warranty period described below. Purchaser is responsible for any shipping cost to our facility and any local labor charges.

- One year on the entire water conditioner
- Five years on the control valve
- Ten years on the mineral tank

GENERAL CONDITIONS – Should a defect or malfunction occur, contact the dealer that you purchased the product from. If you are unable to contact the dealer, contact Franklin Electric Co., Inc., Water Treatment Division @ (260)693-1972. We will require a full description of the problem, model number, date of purchase, and selling dealer’s business name and address.

We assume no warranty liability in connection with this water conditioner other than specified herein. This warranty is in lieu of all other warranties, expressed or implied, including warranties of fitness for a particular purpose. We do not authorize any person or representative to assume for us any other obligations on the sale of this water conditioner.

FILL IN AND KEEP FOR YOUR RECORDS

Original Purchaser	Date of Purchase	Model #	
Address of Original Installation		City	State
Dealer Purchased From	Dealer Address	City	State

Franklin Electric Co., Inc.
Water Treatment Division
12630 U.S. 33 North, Churubusco, IN 46723
Phone: (260)693-1972 Fax: (260)693-0602