



Cash Acme USA
Business Offices
Phone: 1-877-700-4242
Fax: 1-877-700-4280
2727 Paces Ferry Rd SE
Suite 1800, Building Two
Atlanta, GA 30339

Cash Acme Canada
Business Offices
Phone: 1-888-820-0120
Fax: 1-905-265-2775
74 Alex Avenue
Vaughan, Ontario L4L 5X1

Item # 23140-0045, 1" EB25-DUPE Double Union PEX Ends

The EB-25 from Cash Acme brings state-of-the-art water control technology to pressure regulators. The EB-25 has a convenient orange pressure adjustment twist-cap, and numerical indicator which makes installation a quick, one-man job. The unique design also eliminates the water whistle or hum associated with most PRVs, due to innovative "micro-fingers" that dissipate noise as water flows across the seat. And thanks to a patented single-cartridge design, this valve has fewer parts for increased

[+ more](#)

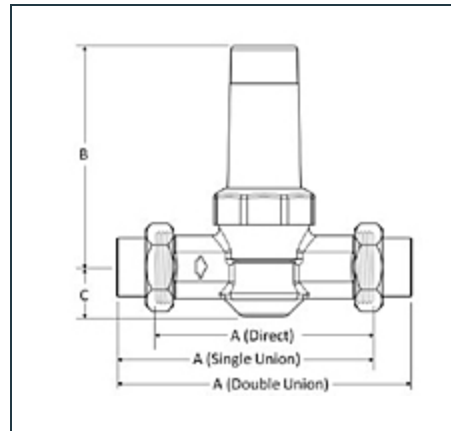

[Specifications](#) | [Dimensions](#) | [Material](#) | [Details](#)

Specifications

Type	Pressure Regulator
Connection Type	PEX
Size	1"
Operating Temperature [Min]	0 °F

Operating Temperature [Max]	180 °F
Operating Pressure [Min]	20 psi
Operating Pressure [Max]	90 psi

Dimensions

Overall Length	7.6 in
Overall Height	5.98 in
B	4.92 in
C	1.06 in

Material

Body Material	Lead Free Bronze or Stainless Steel
Spring Chamfer Material	Nylon
Adjusting Spring Material	Steel (zinc plated)
Pressure Plate Material	Steel (zinc plated)
Diaphragm Material	EPDM
Body Seat Material	Polysulphone
Seat Disc Material	EPDM
Piston Material	Stainless Steel
Strainer Screen Material	Stainless steel

Details

Convenient orange twist-cap eliminates need for wrench adjustment, numerical indicator shows the

Features and Benefits

pressure without the need for a gauge: One person can install, saving money and time! Single piece cartridges can be removed with valve body remaining in place: Service all the parts quicker and easier! Integral backpass check with the cartridge: No add-ons or small parts, longer life and more reliable performance. Cutting edge design and production incorporates “micro-fingers” that dissipate noise due to water flow across the seat: Meets the latest stringent international standards, quieter installation. Certified to ASSE Standard 1003 and CSA Standard B356. Listed by IAPMO and ASSE and certified lead free complying with NSF 372: Inspector friendly for peace of mind. Available with a blanking cap for “rough-in” installations: No more dummy valve necessary. Optional closing cap for direct burial applications: Protects the cartridge from external elements. Assembled and tested in the USA: Prepared in our manufacturing plant in Cullman, Alabama.

Specification

A pressure regulating valve shall be installed to reduce high supplies of incoming water pressure. The valve shall be of a single piece cartridge with a pre-set numerical indicator and micro-fingers for noise dissipation. The valve shall be a Cash Acme EB-25 Pressure Regulator.

Typical Installation

The Cash Acme EB-25 comes supplied with a pre-adjusted pressure set at the factory. Any adjustment to this pressure is easily accomplished by lifting the orange adjustment cap and twisting. The orange adjustment cap can be rotated counter clockwise to decrease pressure and clockwise to increase the pressure. The changes in pressure setting will be visible on the numeric indicator. All pressure adjustments can be made before or after the installation with great ease.

Certifications

Cash Acme Type EB-25 Pressure Regulators are certified to ASSE 1003 and CSA B356 and are listed by ASSE and IAPMO (cUPC). The EB-25 Pressure Regulator is compliant with NSF 372.

Service

Water