



**COMMERCIAL
PRODUCT SPECIFICATIONS**

Bulletin No. KCA-092-150 (02/2020)



**ASHRAE 90.1
COMPLIANT**

**7.5 to 12.5 Tons
Net Cooling Capacity - 86,000 to 138,000 Btuh
Optional Electric Heat - 7.5 to 60 kW**

MODEL NUMBER IDENTIFICATION

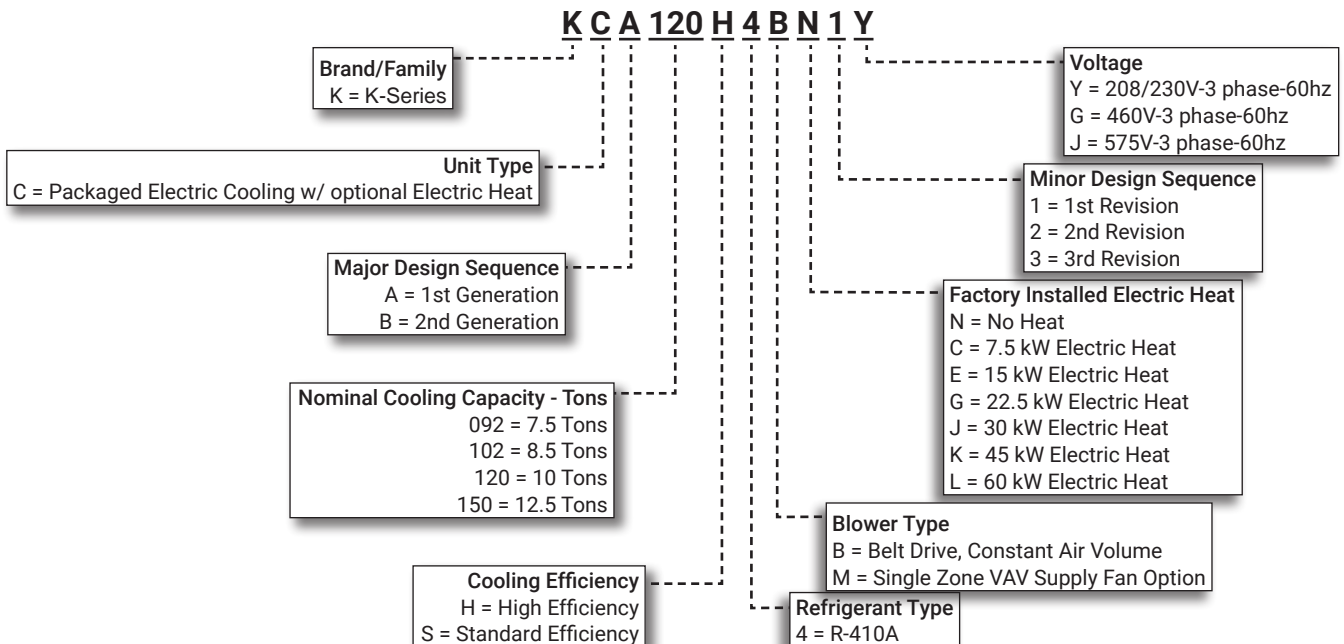

FEATURE HIGHLIGHTS

K-Series rooftop units from Allied are the new standard for reliable, efficient rooftop units built for long-lasting performance that can significantly improve indoor environments.

1. Scroll Compressors
2. Eco-Last™ Coil System
3. Outdoor Coil Fan Motors
4. Heavy Gauge Steel Cabinet
5. Constant or Single Zone VAV Air Volume Blower
6. Unit Control
7. Disconnect Switch (option)
8. Electric Heat (option)
9. Air Filters
10. Economizer (option)
11. Downflow Barometric Relief Dampers (option)

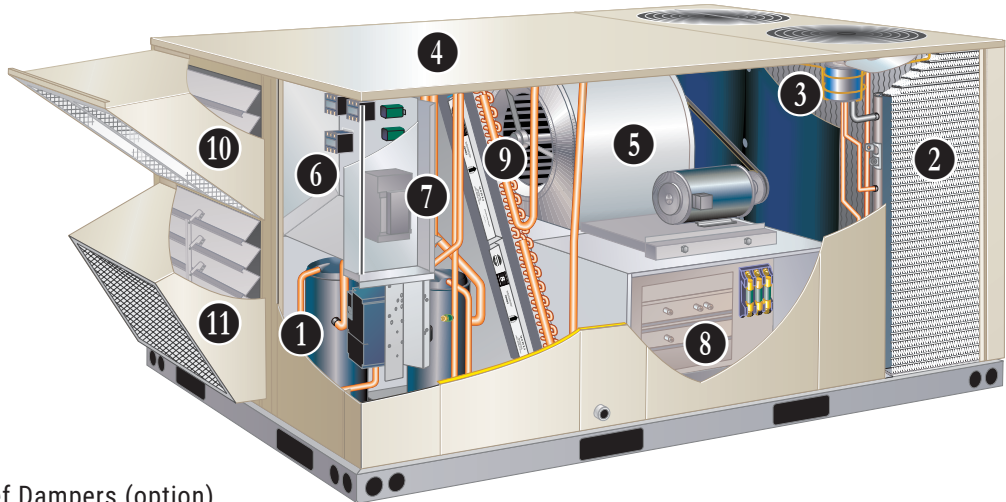

CONTENTS

Approvals And Warranty	3
Blower Data	31
Dimensions - Accessories	46
Dimensions - Unit	45
Electrical/Electric Heat Data	36
Electric Heat Capacities	43
Features And Benefits	3
Dehumidification System Option	11
Dehumidification System Ratings	28
Model Number Identification	1
Optional Conventional Temperature Control Systems	12
Options / Accessories	13
Outdoor Sound Data	30
Ratings	20
Specifications	16
Unit Clearances	43
Weight Data	44

APPROVALS AND WARRANTY

APPROVALS

- AHRI Standard 340/360 certified
- ETL and CSA listed
- CSA certified energy ratings
- Unit and components ETL, NEC and CEC bonded for grounding to meet safety standards for servicing
- All models are ASHRAE 90.1-2010 energy efficiency compliant and meet or exceed requirements of Section 6.8
- All models meet DOE 2018 energy efficiency standards
- Single Zone VAV models meet California Code of Regulations, Title 24 and ASHRAE 90.1-2010 Section 6.4.3.10 requirements for staged airflow
- ISO 9001 Registered Manufacturing Quality System

WARRANTY

- Compressors - Limited five years
- Eco-Last™ Coil System - Limited three years
- High Performance Economizers (optional) - Limited five years
- All other covered components - Limited one year

FEATURES AND BENEFITS

COOLING SYSTEM

- Designed to maximize sensible and latent cooling performance at design conditions
- System can operate from 30°F to 125°F without any additional controls

R-410A Refrigerant

- Non-chlorine based
- Ozone friendly

1 Scroll Compressors

- Scroll compressors on all models for high performance, reliability and quiet operation
- Resiliently mounted on rubber grommets for quiet operation

Compressor Crankcase Heaters

- Protects against refrigerant migration that can occur during low ambient operation or during extended off cycles

Thermal Expansion Valves

(All High Efficiency Models, 150S Model and all Standard Efficiency Models with Dehumidification)

- Assures optimal performance throughout the application range
- Removable element head

Refrigerant Metering Orifice

(092 through 120 Standard Efficiency Models)

- Accurately meters refrigerant in system
- Refrigerant control is accomplished by exact sizing of refrigerant metering orifice

Filter/Driers

- High capacity filter/drier protects the system from dirt and moisture

High Pressure Switches

- Protects the compressor from overload conditions such as dirty condenser coils, blocked refrigerant flow, or loss of outdoor fan operation
- Automatic reset

Freezestats

- Protects the evaporator coil from damaging ice build-up due to conditions such as low/no airflow, or low refrigerant charge

2 Condenser Coil - Eco-Last™ Coil System (092 through 120 models only)

- Lightweight, all aluminum brazed fin construction
- Constructed of three components
 - A flat extrusion tube
 - Fins in-between the flat extrusion tube
 - Two refrigerant manifolds

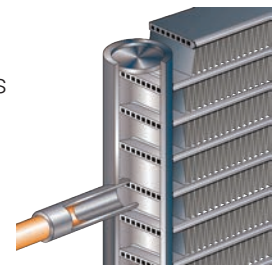

Environ™ Coil System Features:

- Improved heat transfer performance due to high primary surface area (flat tubes) versus secondary surface (fins)
- Smaller internal volume (reduced refrigerant charge)
- High durability
- All aluminum construction
- Fewer brazed joints
- Compact design
- Reduced unit weight
- Easy maintenance/cleaning
- Face split design
- Mounting brackets with rubber inserts

FEATURES AND BENEFITS

COOLING SYSTEM (continued)

Conventional Fin/Tube Condenser Coils (150 models only, optional 092-120 models)

- Copper tube construction
- Enhanced rippled-edge aluminum fins
- Flared shoulder tubing connections
- Silver soldered construction

Evaporator Coil

- Copper tube construction
- Enhanced rippled-edge aluminum fins
- Flared shoulder tubing connections
- Silver soldered construction
- Factory leak tested
- Cross row circuiting with rifled tubing

Condensate Drain Pan

- Plastic pan, sloped to meet drainage requirements per ASHRAE 62.1
- Side or bottom drain connections
- Reversible to allow connection at back of unit

3 Outdoor Coil Fan Motors

- Thermal overload protected
- Totally enclosed
- Permanently lubricated ball bearings
- Shaft up
- Wire basket mount

Outdoor Coil Fans

- PVC coated fan guard furnished

Required Selections

Cooling Capacity

- Specify nominal cooling capacity

Cooling Efficiency

- Specify either standard or high efficiency

Options/Accessories

Factory Installed

Conventional Fin/Tube Condenser Coil (replaces Eco-Last™ Coil System - 092 through 120 models only)

- Copper tube construction
- Enhanced rippled-edge aluminum fins
- Flared shoulder tubing connections
- Silver soldered construction

NOTE - Required if Dehumidification System is ordered.

Field Installed

Condensate Drain Trap

- Available in copper or PVC

Drain Pan Overflow Switch

- Monitors condensate level in drain pan
- Shuts down unit if drain becomes clogged

Low Ambient Controls

- Units operate satisfactorily down to 45°F outdoor air temperature without any additional controls
- Two low ambient control options are available for field installation:
 1. **Low Ambient Control Kit (30°F)** - Allows unit operation down to 30°F
 2. **Low Ambient Control Kit (0°F)** - Allows unit operation down to 0°F without evaporator coil icing. Head pressure speed control reduces outdoor fan operation during low ambient conditions until head pressure rises to the setpoint. Pressure transducers are mounted on the liquid lines. High pressure switches are furnished to replace existing. Wiring harnesses are furnished for simple plug-in wiring to fans and controller.

CABINET

4 Construction

- Heavy-gauge steel panels
- Full perimeter heavy-gauge galvanized steel base rail
- Base rails have rigging holes
- Three sides of the base rail have forklift slots
- Raised edges around duct and power entry openings in the bottom of the unit for water protection

Airflow Choice

- Units are shipped in downflow (vertical) return air flow configuration

NOTE - Units can be field converted to horizontal airflow with optional Horizontal Discharge Kit.

Duct Flanges

- Provided for horizontal duct attachment

Power Entry

- Electrical lines can be brought through the unit base or through horizontal access knock-outs

Exterior Panels

- Constructed of heavy-gauge, galvanized steel
- Two-layer enamel paint finish

Insulation

- Fully insulated with non-hygroscopic fiberglass insulation (conditioned areas)
- Unit base is fully insulated
- Base insulation serves as an air seal to the roof curb, eliminating the need to add a seal during installation

Access Panels

- Filter section
- Blower/heating section
- Compressor/controls section

FEATURES AND BENEFITS

CABINET (continued)

Options/Accessories

Factory Installed

Corrosion Protection

- Completely flexible immersed coating
- Electrodeposited dry film process
- AST ElectroFin E-Coat
- Meets Mil Spec MIL-P-53084, ASTM B117 Standard Method Salt Spray Testing
- Indoor Corrosion Protection:
 - Coated coil
 - Coated reheat coil (Dehumidification)
 - Painted blower housing
 - Painted base
- Outdoor Corrosion Protection:
 - Coated coil
 - Painted outdoor base

Options/Accessories

Factory Installed

Hinged Access Panels

- Tool-less access
- Filter section
- Blower/heating section
- Compressor/controls section
- Panel seals and quarter-turn latching handles provide a tight air and water seal

Field Installed

Combination Coil/Hail Guards

- Heavy gauge steel frame
- Painted to match cabinet
- Expanded metal mesh protects outdoor coil

Horizontal Discharge Kit

- Consists of duct covers to block off downflow supply and return air openings for horizontal applications
- Also includes return air duct flanges for end return air when economizer is used in horizontal applications

NOTE - When configuring unit for horizontal application with economizer, a separate Horizontal Barometric Relief Damper with Hood must be ordered separately for installation in the return air duct.

Return Air Adaptor Plate

- For same size LC/LG/LH and TC/TG/TH unit replacement
- Installs on return air opening in unit to match return air opening on existing roof curbs
- Also see Accessory Air Resistance table

BLOWER

- A wide selection of supply air blower options are available to meet a variety of airflow requirements

Motor

- Overload protected
- Ball bearings
- Belt drive motors are offered on all models and are available in several different sizes to maximize air performance

5 Supply Air Blower

- Forward curved blades
- Double inlet
- Blower wheel statically and dynamically balanced
- Ball bearings
- Adjustable pulley (allows speed change)
- Blower assembly slides out of unit for servicing

Required Selections

Select Constant Air Volume (CAV) or Single Zone VAV Supply Fan Blower Option

- Order blower motor horsepower and drive kit number required when base unit is ordered
- See Drive Kit Specifications Table

CAV Operation

- Supply air blower will provide a constant volume of air

Single Zone VAV Supply Fan Operation

- Units utilize a Variable Frequency Drive (VFD) to stage the supply air blower airflow
- The VFD alters the frequency and voltage of the power supply to the blower to control blower speed
- The supply air blower has two speeds:
 - Low speed for part-load cooling operation. Note - Low speed is 66% of high speed
 - High speed for full load cooling and all heat modes
- Full speed blower operation is set by adjusting the motor pulley to deliver the desired air volume
- The ventilation speed is selectable between high and low speed

NOTE - Part load airflow in cooling mode on **Single Zone VAV Supply Fan** units should not be set below 220 cfm/nominal full load ton to reduce the risk of evaporator coil freeze-up.

- The VFD has an operational range of -40 to 125° F outdoor air ambient temperature
- Lower operating costs are obtained when the blower is operated on lower speeds

FEATURES AND BENEFITS

BLOWER (continued)

Single Zone VAV Supply Fan Sequence of Operation

- Ventilation speed is determined by the VENT SPEED switch setting on VFD control board (LO or HI)
- Blower operates in low speed for mechanical cooling (Y1)
- Blower operates in high speed for any other mode (free cooling, mechanical cooling Y1+Y2, and heating)
- Economizer damper minimum position is fully closed in unoccupied mode
- In occupied mode, the economizer damper minimum position is determined by the setting of the two potentiometers on VFD control board:
 - LO SPD MIN POS potentiometer sets the minimum position when blower is operating at low speed
 - HI SPD MIN POS potentiometer sets the minimum position when blower is operating at high speed

Options/Accessories

Field Installed

VFD Manual Bypass Kit

- VFD Manual Bypass Control is available as a kit for units equipped with the Single Zone VAV Supply Fan option
- The VFD Manual Bypass Control is a manual bypass and is enabled by re-configuring the wiring on the unit

CONTROLS

6 Unit Control

- All control voltage is provided via a 24V (secondary) transformer with built-in circuit breaker protection
- **Heat/Cool Staging** - Capable of up to 2 heat / 2 cool staging with a third party DDC control system or thermostat
- **Low Voltage Terminal Block** - Provides screw terminal connections for thermostat or controller wiring
- **Night Setback Mode** - Saves energy by closing outdoor air dampers and operating supply fan on thermostat demand only

Options/Accessories

Field Installed

Smoke Detector

- Photoelectric type
- Installed in supply air section, return air section or both sections
- Available with power board and single sensor (supply or return) or power board and two sensors (supply and return)

Thermostats

- Control system and thermostat options, see page 12

FEATURES AND BENEFITS

ELECTRICAL

Marked & Color-Coded Wiring

- All electrical wiring is color-coded and marked to identify which components it is connecting

Electrical Plugs

- Positive connection electrical plugs are used to connect common accessories or maintenance parts for easy removal or installation

Phase Monitor

(Factory Installed on Units Equipped with the Single Zone VAV Supply Fan)

- Phase monitor located in the control compartment detects the phasing of incoming power
- If the incoming power is out of phase or if any of the three phases are lost, an indicator LED on the phase monitor will turn red and the unit will not start
- In normal operation with correct incoming power phasing, the LED will be green

Required Selections

Voltage Choice

- Specify when ordering base unit

Options/Accessories

Factory or Field Installed

7 Disconnect Switch

- Accessible from outside of unit
- Spring loaded weatherproof cover
- See Electrical/Electric Heat tables for ordering information, page 36

8 Electric Heat

- Helix wound nichrome elements
- Individual element limit controls
- Wiring harness
- Unit fuse block
- See Options / Accessories tables for ordering information

NOTE - Factory installed electric heat is only available with high efficiency models.

GFI Service Outlets (2)

- 115V ground fault circuit interrupter (GFCI) type
- Non-powered
- Field-wired

Field Installed

GFI Weatherproof Cover

- Single-gang cover
- Heavy-duty UV-resistant polycarbonate case construction
- Hinged base cover with gasket

INDOOR AIR QUALITY

9 Air Filters

- Disposable 2 inch filters furnished as standard

Options/Accessories

Field Installed

High Efficiency Air Filters

- Disposable MERV 8 or MERV 13 (Minimum Efficiency Reporting Value based on ASHRAE 52.2) efficiency 2 inch pleated filters

Replacement Filter Media Kit With Frame

- Replaces existing pleated filter media. Includes washable metal mesh screen and metal frame with clip for holding replaceable non-pleated filter

Options/Accessories

Field Installed UVC Germicidal Lamps



- Germicidal lamps emit ultra-violet (UV-C) energy, which has been proven to be effective in reducing microbes such as viruses, bacteria, yeasts, and molds. This process either destroys the organism or controls its ability to reproduce.
- UV-C energy greatly reduces the growth and proliferation of mold and other bioaerosols (bacteria and viruses) on illuminated surfaces (particularly coil and drain pan)
- Lamps are field installed in the blower/evaporator coil section
- All necessary hardware for installation is included
- Lamps operate on 208/230V power supply. Step-down transformer must be field supplied when used with 460V and 575V rooftop units
- Magnetic safety interlock terminates power when access panels are removed
- Approved by ETL

Indoor Air Quality (CO₂) Sensors

- Monitors CO₂ levels, reports to the Unit Controller which adjusts economizer dampers as needed

OPTIONS / ACCESSORIES

ECONOMIZER OPTIONS

Factory or Field Installed

10 Economizer (Standard and High Performance Common Features)

- Downflow or Horizontal with Outdoor Air Hood and Barometric Relief Dampers with Exhaust Hood

- #### 11
- Barometric Relief Dampers allow relief of excess air
 - Aluminum blade dampers prevent blow back and outdoor air infiltration during off cycle
 - Bird screen furnished

NOTE - Optional Horizontal Low Profile Barometric Relief Dampers with Exhaust Hood are available for field installation in a reduced space.

- Occupied/Unoccupied mode with field furnished setback thermostat
- Demand Control Ventilation (DCV) ready using optional CO₂ sensors
- Mixed Air Sensor is furnished for field installation in the rooftop unit
- Sensor is factory installed when Economizers are factory installed
- Single sensible sensor is furnished with Economizer and enables economizer operation if the outdoor temperature is less than the setpoint of the control

Standard Economizer Features (Not for Title 24)

- Gear-driven action
- Return air and outdoor air dampers
- Plug-in connections to unit
- Nylon bearings
- Nneoprene seals
- 24-volt
- Fully-modulating spring return motor

Standard Economizer Control Module

- The Standard Economizer Control Module can be adjusted to operate based on outdoor air temperatures

Economizer Controls:

- **Damper Minimum Position** - Can be set lower than traditional minimum air requirements resulting in cost savings
- **IAQ Sensor** - Signals dampers to modulate and maintain 55°F when CO₂ is higher than the CO₂ setpoint
- **Demand Control Ventilation (DCV) LED** - A steady green Demand Control Ventilation LED indicates the IAQ reading is higher than setpoint and requires more fresh air
- **Free Cool LED** - A steady green LED indicates outdoor air is suitable for free cooling
- Free Cooling runs when outdoor air temperature is lower than the set temperature on the economizer control

NOTE: The Free Cooling default setting for outdoor air temperature sensor is 55°F.



OPTIONS / ACCESSORIES

ECONOMIZER OPTIONS (continued)

Factory or Field Installed

High Performance Economizer Features

- Approved for California Title 24 building standards
- Low leakage dampers are Air Movement and Control Association International (AMCA) Class 1A Certified - Maximum 3 CFM per sq. ft. leakage at 1 in. w.g.
- ASHRAE 90.1-2010 compliant
- Gear-driven action
- High torque 24-volt fully-modulating spring return damper motor
- Return air and outdoor air dampers
- Plug-in connections to unit
- Stainless steel bearings
- Enhanced neoprene blade edge seals
- Flexible stainless steel jamb seals minimize air leakage

NOTE - High Performance Economizers are not approved for use with enthalpy controls in Title 24 applications.

NOTE - The Free Cooling setpoint for Title 24 applications must be set based on the Climate Zone where the system is installed. See Section 140.4 "Prescriptive Requirements for Space Conditioning Systems" of the California Energy Commission's 2013 Building Energy Efficiency Standards. Refer to Installation Instructions for complete setup information and menu parameters available.

High Performance Economizer Control Module

- Module provides inputs and outputs to control economizer based on parameter settings
- Module automatically detects sensors by polling to determine which sensors are installed in system
- Module displays any alarm messages (fault detection and diagnostics) as an aid in troubleshooting
- Non-volatile memory retains parameter settings in case of power failure
- Keypad with four navigation buttons and LCD screen is furnished for setting economizer parameters
 - Menu Up/Exit (⬆️) button returns to the main menu
 - Arrow Up (▲) button moves to the previous or next parameter within the selected menu
 - Arrow Down (▼) button moves to the next parameter within the selected menu
 - Select (enter) (↵) button confirms parameter selection



Main Menu Structure:

- STATUS (economizer and system operation status)
- SETPOINTS (settings for various setpoint parameters)
- SYSTEM SETUP (settings/information about the system)
- ADVANCED SETUP (freeze protection, CO₂ settings, stage 3 delay and additional calibration settings)
- CHECKOUT (damper positions)
- ALARMS (output signal that can be configured for remote alarm monitoring)

NOTE - Refer to Installation Instructions for complete setup information and menu parameters available.

Factory or Field Installed

Single Enthalpy Temperature Control (Not for Title 24)

- Outdoor air enthalpy sensor enables Economizer if the outdoor enthalpy is less than the setpoint of the control

Field Installed

Differential Enthalpy Control (Not for Title 24)

- Order two Single Enthalpy Controls
- One is field installed in the return air section, the other in the outdoor air section
- Allows the economizer control board to select between outdoor air or return air, whichever has lower enthalpy

OPTIONS / ACCESSORIES

EXHAUST OPTIONS

Field Installed

Horizontal Low Profile Barometric Relief Dampers

- Replaces barometric relief dampers furnished with Economizer
- For use when unit is configured for horizontal applications in a reduced space requiring an economizer
- Allows relief of excess air
- Aluminum blade dampers prevent blow back and outdoor air infiltration during off cycle
- Field installed in return air duct
- Exhaust hood with bird screen furnished

NOTE - Requires Horizontal Discharge Kit

Power Exhaust Fan

- Installs internal to unit for downflow applications only with economizer option
- Provides exhaust air pressure relief
- Interlocked to run when supply air blower is operating,
- Fan runs when outdoor air dampers are 50% open (adjustable)
- Motor is overload protected
- Fan is 20 in. diameter
- Five blades
- One 1/3 hp motor

NOTE - Requires Economizer and Downflow Barometric Relief Dampers.

OUTDOOR AIR OPTIONS

Factory or Field Installed

Outdoor Air Damper

- Downflow or Horizontal
- Linked mechanical dampers
- 0 to 25% (fixed) outdoor air adjustable
- Installs in unit
- Includes outdoor air hood
- Automatic model features fully modulating spring return damper motor with plug-in connection
- Manual model features parallel blade, gear-driven dampers with adjustable fixed position

NOTE - Maximum mixed air temperature in cooling mode: 100°F.

ROOF CURBS

Field Installed

- Nail strip furnished (downflow only)
- Mates to unit
- US National Roofing Contractors Approved
- Shipped knocked down

Hybrid Roof Curbs, Downflow

- Interlocking tabs fasten corners together
- No tools required
- Can also be fastened together with furnished hardware
- Available in 8, 14, 18, and 24 inch heights

Adjustable Pitch Curb

- Fully adjustable pitch curbs (3/4 in. per foot in any direction) provide a level platform for rooftop units allowing flexible installations on roofs with uneven or sloped angles
- Uses interlocking tabs to fasten corners together
- No tools required
- Hardware is furnished to connect upper curb with lower curb
- Available in 14 inch height

Adaptor Curbs (not shown)

- Curbs are regionally sourced
- Dimensions vary based upon the source

NOTE - Contact your local sales representative for a detailed cut sheet with applicable dimensions.

CEILING DIFFUSERS

Field Installed

Ceiling Diffusers (Flush or Step-Down)

- White powder coat finish on diffuser face and grilles
- Insulated UL listed duct liner
- Diffuser box has collars for duct connection
- Step-down diffusers have double deflection blades
- Flush diffusers have fixed blades
- Provisions for suspending
- Internally sealed to prevent recirculation
- Removable return air grille
- Adapts to T-bar ceiling grids or plaster ceilings

Transitions (Supply and Return)

- Used with diffusers
- Installs in roof curb
- Galvanized steel construction
- Flanges furnished for duct connection to diffusers
- Fully insulated

DEHUMIDIFICATION SYSTEM OPTION

OVERVIEW

NOTE - Not available with Eco-Last™ Coil System.
Conventional Fin/Tube condenser coil must be ordered as a factory option.

- Factory installed option designed to control humidity
- Provides dehumidification on demand using ASHRAE 90.1 recommended method for comfort conditioning humidity control
- Unit comes equipped with one row reheat coil, solenoid valve and humidity controller
- A thermostat with a dehumidification output, a dehumidistat, or a DDC controller with an isolated output is required to control humidity and must be located in the occupied space

NOTE - Controls are not furnished and must be ordered separately.

BENEFITS

- Improves indoor air quality
- Helps prevent damage due to high humidity levels
- Improves comfort levels by reducing space humidity levels

OPERATION

No Dehumidification Demand

- The unit will operate conventionally whenever there is a demand for cooling or heating and no dehumidification demand
- Free cooling is only permitted when there is no demand for dehumidification

Dehumidification Demand Only

- Dehumidification is initiated by an output from a dehumidistat (furnished), an optional thermostat with a dehumidification output or an optional DDC controller with an isolated output to control humidity
- Reheat operation will initiate on a dehumidification demand and does not require a cooling demand
- The unit will operate in the dehumidification mode until the relative humidity of the conditioned space is below the setpoint
- This operation reduces sensible cooling capacity and extends compressor run time to control humidity when the cooling load is low
- A solenoid valve diverts hot gas from the compressor to the reheat coil
- The cooled and dehumidified air from the evaporator is reheated as it passes through the reheat coil
- The de-superheated and partially condensed refrigerant continues to the outdoor condenser coil where condensing is completed
- Unit will continue to operate in this mode until the dehumidification demand is satisfied

Dehumidistat Furnished

- Furnished for field installation
- Remote mounted dehumidistat for factory installed Dehumidification option
- Adjustable 20-80%

NOTE - A thermostat with a dehumidification output or a DDC controller with an isolated output can be used instead.

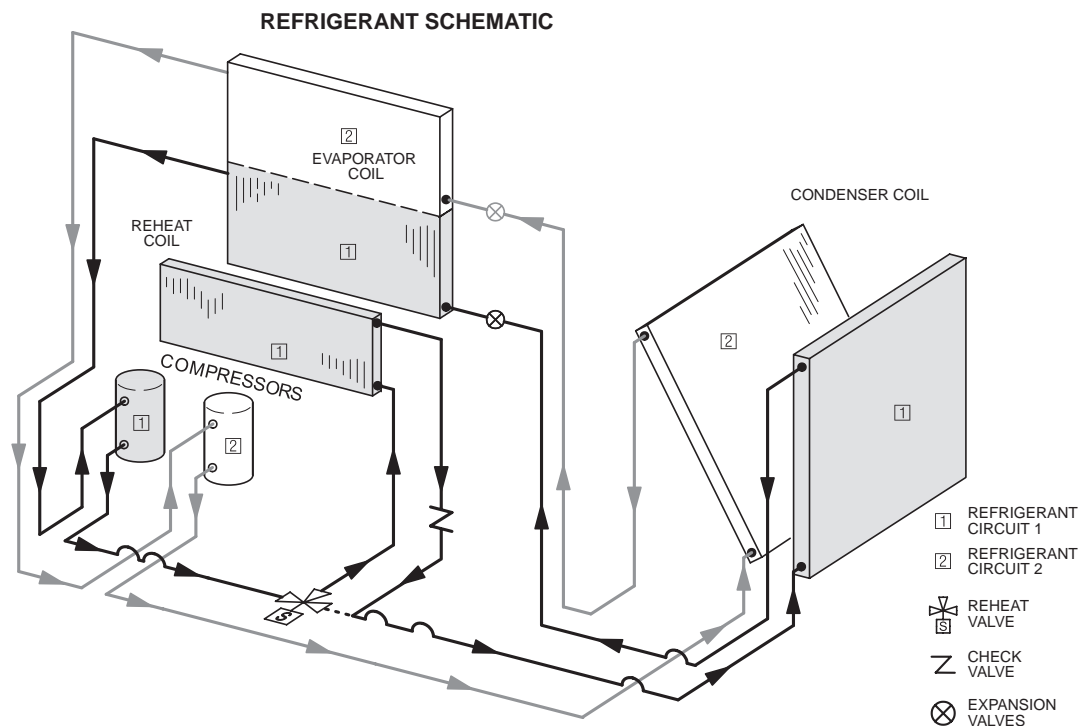

OPTIONAL CONVENTIONAL TEMPERATURE CONTROL SYSTEMS

Bacnet Compatible Thermostat With Reheat Function



- 7-Day Programmable
- For units with or without Dehumidification option
- BTL listed MS/TP ensures compatibility with any BACnet system
- Built-in control programs for conventional and heat pump applications
- Conventional systems up to 3-stage heat and 3-stage cool
- Heat pumps with 1 or 2 compressors and up to 2-stage auxiliary heat
- On-board temperature and humidity sensor
- Multiple configurable inputs and outputs enable advanced control strategies
- Set-up Wizard enables rapid system configuration
- No special tools required for installation or commissioning
- Seven-day (2, 4 or 6 event) occupancy scheduling per day
- Backlit 5-inch LCD touchscreen

Description	Model No.	Catalog No.
¹ 7-Day Programmable - Bacnet Compatible	- - -	Y8241

¹ BACnet Thermostat (Y8241) will control units with and without the Humiditrol® option. If there is a mix of units equipped with and without Humiditrol on the same site, this thermostat can be used for all units if desired.

OPTIONS / ACCESSORIES

Item Description	Model Number	Catalog Number	Unit Model No			
			092	102	120	150
COOLING SYSTEM						
Condensate Drain Trap	PVC - C1TRAP20AD2	76W26	X	X	X	X
	Copper - C1TRAP10AD2	76W27	X	X	X	X
Conventional Fin/Tube Condenser Coil (Replaces Eco-Last™ Coil System) (Required for Dehumidification option)		Factory	O	O	O	
Corrosion Protection		Factory	O	O	O	O
Drain Pan Overflow Switch	K1SNSR71AB1-	74W42	X	X	X	X
Efficiency		High	O	O	O	O
		Standard	O	O	O	O
Low Ambient Kits	30°F - K1SNSR33B-1	54W16	X	X	X	X
	0°F - K1LOAM62B-1	18B87	X	X	X	
	0°F - K1LOAM62BS1	18B94				X
Refrigerant Type		R-410A	O	O	O	O
BLOWER - SUPPLY AIR						
Blower Option	CAV (Constant Air Volume)	Factory	O	O	O	O
	Single Zone VAV Supply Fan	Factory	O	O	O	O
Blower Motors	Belt Drive - 2 hp	Factory	O	O	O	O
	Belt Drive - 3 hp	Factory	O	O	O	O
	Belt Drive - 5 hp	Factory	O	O	O	O
VFD Manual Bypass Kit (for Single Zone VAV Supply Fan equipped units only)	KVFD12C-1	90W53	X	X	X	X
Drive Kits	Kit #1 590-890 rpm	Factory	O	O	O	O
See Blower Data Tables for selection	Kit #2 800-1105 rpm	Factory	O	O	O	O
	Kit #3 795-1195 rpm	Factory	O	O	O	O
	Kit #7 730-970 rpm	Factory	O	O	O	O
	Kit #8 940-1200 rpm	Factory	O	O	O	O
	Kit #9 1015-1300 rpm	Factory	O	O	O	O
	Kit #10 900-1135 rpm	Factory	O	O	O	O
	Kit #11 1040-1315 rpm	Factory	O	O	O	O
	Kit #12 1125-1425 rpm	Factory	O	O	O	O
	CABINET					
	Combination Coil/Hail Guards	C1GARD52B-1	13T05	X	X	X
Hinged Access Panels		Factory	O	O	O	O
Horizontal Discharge Kit	K1HECK00B-1	51W25	X	X	X	X
Return Air Adaptor Plate (for LC/LG/LH and TC/TG/TH unit replacement)	C1CONV10B-1	54W96	X	X	X	X
CONTROLS						
NOTE - Also see Conventional Thermostat Control Systems page 12 for Additional Options.						
Smoke Detector - Supply or Return (Power board and one sensor)	C1SNSR44B-2	11K76	X	X	X	X
Smoke Detector - Supply and Return (Power board and two sensors)	C1SNSR43B-2	11K80	X	X	X	X

NOTE - Catalog and model numbers shown are for ordering field installed accessories.

OX - Configure To Order (Factory Installed) or Field Installed

O = Configure To Order (Factory Installed)

X = Field Installed

OPTIONS / ACCESSORIES

Item Description	Model Number	Catalog Number	Unit Model No			
			092	102	120	150
INDOOR AIR QUALITY						
Air Filters						
High Efficiency Air Filters	MERV 8 - C1FLTR15B-1	50W61	X	X	X	X
20 x 25 x 2 (Order 4 per unit)	MERV 13 - C1FLTR40B-1	52W41	X	X	X	X
Replacement Media Filter With Metal Mesh Frame (includes non-pleated filter media)	C1FLTR30B-1-	Y3063	X	X	X	X
Indoor Air Quality (CO₂) Sensors						
Sensor - Wall-mount, off-white plastic cover with LCD display	C0SNSR50AE1L	77N39	X	X	X	X
Sensor - Wall-mount, off-white plastic cover, no display	C0SNSR52AE1L	87N53	X	X	X	X
Sensor - Black plastic case with LCD display, rated for plenum mounting	C0SNSR51AE1L	87N52	X	X	X	X
Sensor - Wall-mount, black plastic case, no display, rated for plenum mounting	C0MISC19AE1	87N54	X	X	X	X
CO ₂ Sensor Duct Mounting Kit - for downflow applications	C0MISC19AE1-	85L43	X	X	X	X
Aspiration Box - for duct mounting non-plenum rated CO ₂ sensors (87N53 or 77N39)	C0MISC16AE1-	90N43	X	X	X	X
UVC Germicidal Lamps						
¹ UVC Light Kit (208/230v-1ph)	C1UVCL10B-1	54W62	X	X	X	X
dehumidification condenser reheat option						
Dehumidification Option		Factory	O	O	O	O
² Dehumidistat, Remote Mounted	C0SNSR30FF1L	99N41	X	X	X	X
ELECTRICAL						
Voltage 60 hz	208/230V - 3 phase	Factory	O	O	O	O
	460V - 3 phase	Factory	O	O	O	O
	575V - 3 phase	Factory	O	O	O	O
Disconnect Switch - See Electrical/Electric Heat tables for selection	80 amp - C1DISC080B-1	54W56	OX	OX	OX	OX
	150 amp - C1DISC150B-1	54W57	OX	OX	OX	OX
GFI Service Outlets 15 amp non-powered, field-wired (208/230V, 460V only)	LTAGFIK10/15	74M70	OX	OX	OX	OX
	20 amp non-powered, field-wired (575V only)	C1GFCI20FF1	67E01	X	X	X
Weatherproof Cover for GFI	C1GFCI99FF1	10C89	X	X	X	X
³ ELECTRIC HEAT						
7.5 kW	208/230V-3ph - C1EH0075B-1Y	56W38	OX	OX		
	460V-3ph - C1EH0075B-1G	56W39	OX	OX		
	575V-3ph - C1EH0075B-1J	56W40	OX	OX		
15 kW	208/230V-3ph - C1EH0150B-1Y	56W41	OX	OX	OX	OX
	460V-3ph - C1EH0150B-1G	56W42	OX	OX	OX	OX
	575V-3ph - C1EH0150B-1J	56W43	OX	OX	OX	OX
22.5 kW	208/230V-3ph - C1EH0225B-1Y	56W44	OX	OX	OX	OX
	460V-3ph - C1EH0225B-1G	56W45	OX	OX	OX	OX
	575V-3ph - C1EH0225B-1J	56W46	OX	OX	OX	OX
30 kW	208/230V-3ph - C1EH0300B-1Y	56W47	OX	OX	OX	OX
	460V-3ph - C1EH0300B-1G	56W48	OX	OX	OX	OX
	575V-3ph - C1EH0300B-1J	56W49	OX	OX	OX	OX
45 kW	208/230V-3ph - C1EH0450B-1Y	56W50	OX	OX	OX	OX
	460V-3ph - C1EH0450B-1G	56W51	OX	OX	OX	OX
	575V-3ph - C1EH0450B-1J	56W52	OX	OX	OX	OX
60 kW	208/230V-3ph - C1EH0600B-1Y	55W02			OX	OX
	460V-3ph - C1EH0600B-1G	55W03			OX	OX
	575V-3ph - C1EH0600B-1J	55W04			OX	OX

¹ Lamps operate on 110-230V single-phase power supply. Step-down transformer may be ordered separately for 460V and 575V units. Alternately, 110V power supply may be used to directly power the UVC ballast(s).

² A thermostat with a dehumidification output or a DDC controller with an isolated output can be used instead.

³ NOTE - Factory installed electric heat is only available with high efficiency models.

NOTE - Catalog and model numbers shown are for ordering field installed accessories.

OX - Configure To Order (Factory Installed) or Field Installed

O = Configure To Order (Factory Installed)

X = Field Installed

OPTIONS / ACCESSORIES

Item Description	Model Number	Catalog Number	Unit Model No			
			092	102	120	150
ECONOMIZER						
Standard Economizer (Not for Title 24)						
Standard Economizer with Single Temperature Control Downflow or Horizontal Applications - Includes Barometric Relief Dampers and Air Hoods	K1ECON20B-2	13U45	OX	OX	OX	OX
Standard Economizer Controls (Not for Title 24)						
Single Enthalpy Control	C1SNSR64FF1	53W64	OX	OX	OX	OX
Differential Enthalpy Control (order 2)	C1SNSR64FF1	53W64	X	X	X	X
High Performance Economizer (Approved for California Title 24 Building Standards / AMCA Class 1A Certified)						
High Performance Economizer with Single Temperature Control Downflow or Horizontal Applications - Includes Barometric Relief Dampers and Air Hoods	K1ECON22B-3	17U09	OX	OX	OX	OX
High Performance Economizer Controls (Not for Title 24)						
Single Enthalpy Control	C1SNSR60FF1	10Z75	OX	OX	OX	OX
Differential Enthalpy Control (order 2)	C1SNSR60FF1	10Z75	X	X	X	X
Horizontal Low Profile Barometric Relief Dampers With Exhaust Hood						
Horizontal Low Profile Barometric Relief Dampers With Exhaust Hood	LAGEDH03/15	53K04	X	X	X	X
OUTDOOR AIR						
Outdoor Air Dampers With Outdoor Air Hood						
Motorized	C1DAMP20B-1	14G28	OX	OX	OX	OX
Manual	C1DAMP10B-1	14G29	OX	OX	OX	OX
POWER EXHAUST						
Standard Static	208/230V-3ph - K1PWRE10B-1Y	53W44	X	X	X	X
	460V-3ph - K1PWRE10B-1G	53W45	X	X	X	X
	575V-3ph - K1PWRE10B-1J	53W46	X	X	X	X
ROOF CURBS						
Hybrid Roof Curbs, Downflow						
8 in. height	C1CURB70B-1	11F54	X	X	X	X
14 in. height	C1CURB71B-1	11F55	X	X	X	X
18 in. height	C1CURB72B-1	11F56	X	X	X	X
24 in. height	C1CURB73B-1	11F57	X	X	X	X
Adjustable Pitch Curb						
14 in. height	C1CURB55B-1	54W50	X	X	X	X
CEILING DIFFUSERS						
Step-Down - Order one	RTD11-95S	13K61	X			
	RTD11-135S	13K62		X	X	
	RTD11-185S	13K63				X
Flush - Order one	FD11-95S	13K56	X			
	FD11-135S	13K57		X	X	
	FD11-185S	13K58				X
Transitions (Supply and Return) - Order one	C1DIFF30B-1	12X65	X			
	C1DIFF31B-1	12X66		X	X	
	C1DIFF32B-1	12X67				X

NOTE - Catalog and model numbers shown are for ordering field installed accessories.

OX - Configure To Order (Factory Installed) or Field Installed

O = Configure To Order (Factory Installed)

X = Field Installed

SPECIFICATIONS

7.5 TON

General Data		Nominal Tonnage	7.5 Ton	7.5 Ton	7.5 Ton	7.5 Ton
Model Number			KCB092S4B	KCB092S4M	KCA092H4B	KCA092H4M
Efficiency Type			Standard	Standard	High	High
Blower Type			CAV (Constant Air Volume)	Single Zone VAV Supply Fan	CAV (Constant Air Volume)	Single Zone VAV Supply Fan
Cooling Performance	Gross Cooling Capacity - Btuh		87,800	87,800	93,000	93,000
	¹ Net Cooling Capacity - Btuh		86,000	86,000	90,000	90,000
	AHRI Rated Air Flow - cfm		2400	2400	3000	2800
	Total Unit Power - kW		7.7	7.7	7.1	7.1
	¹ EER (Btuh/Watt)		11.2	11.2	12.7	12.7
	¹ IEER (Btuh/Watt)		12.9	13.6	13.0	14.0
Refrigerant Charge	Refrigerant Type		R-410A	R-410A	R-410A	R-410A
	Eco-Last™ Coil System	Circuit 1	4 lbs. 0 oz.	4 lbs. 0 oz.	6 lbs. 6 oz.	6 lbs. 6 oz.
		Circuit 2	3 lbs. 6 oz.	3 lbs. 6 oz.	6 lbs. 7 oz.	6 lbs. 7 oz.
	Conventional Fin/Tube Coil Option	Circuit 1	9 lbs. 0 oz.	9 lbs. 0 oz.	---	---
		Circuit 2	6 lbs. 13 oz.	6 lbs. 13 oz.	---	---
	Conventional Fin/Tube with Dehumidification Option	Circuit 1	10 lbs. 4 oz.	10 lbs. 4 oz.	---	---
		Circuit 2	7 lbs. 0 oz.	7 lbs. 0 oz.	---	---
Electric Heat Available - See page 14			7.5, 15, 22.5, 30 & 45 KW			
Compressor Type (number)			Scroll (2)	Scroll (2)	Scroll (2)	Scroll (2)
Outdoor Coils	Net face area (total) - sq. ft.		20.5	20.5	28.0	28.0
	Eco-Last™ (Fin/Tube)	Number of rows	1 (2)	1 (2)	1	1
Fins per inch		23 (20)	23 (20)	20	20	
Outdoor Coil Fans	Motor - (No.) hp		(2) 1/3	(2) 1/3	(2) 1/3	(2) 1/3
	Motor rpm		1075	1075	1075	1075
	Total Motor watts		740	740	800	800
	Diameter - (No.) in.		(2) 24	(2) 24	(2) 24	(2) 24
	Number of blades		3	3	3	3
	Total Air volume - cfm		8800	8800	8800	8800
	Indoor Coils	Net face area (total) - sq. ft.		12.78	12.78	12.78
Tube diameter - in.		3/8	3/8	3/8	3/8	
Number of rows		2	2	4	4	
Fins per inch		14	14	14	14	
Drain connection - Number and size		(1) 1 in. NPT coupling				
Expansion device type		Refrigerant Metering Orifice (RFC) - No Dehumidification Dehumidification Option		Balanced port TXV, removable head - Dehumidification Option		
² Indoor Blower and Drive Selection	Nominal motor output		2 hp, 3 hp, 5 hp			
	Maximum usable motor output (US Only)		2.3 hp, 3.45 hp, 5.75 hp			
	Motor - Drive kit number		2 hp Kit 1 590-890 rpm Kit 2 800-1105 rpm Kit 3 795-1195 rpm 3 hp Kit 7 730-970 rpm Kit 8 940-1200 rpm Kit 9 1015-1300 rpm 5 hp Kit 10 900-1135 rpm Kit 11 1040-1315 rpm Kit 12 1125-1425 rpm			
Blower wheel nominal diameter x width - in.			(1) 15 X 15	(1) 15 X 15	(1) 15 X 15	(1) 15 X 15
Filters	Type of filter		Disposable			
	Number and size - in.		(4) 20 x 25 x 2			
Electrical characteristics			208/230V, 460V or 575V - 60 hertz - 3 phase			

NOTE - Net capacity includes evaporator blower motor heat deduction. Gross capacity does not include evaporator blower motor heat deduction.

¹ AHRI Certified to AHRI Standard 340/360; 95°F outdoor air temperature and 80°F db/67°F wb entering evaporator air; minimum external duct static pressure.

² Using total air volume and system static pressure requirements determine from blower performance tables rpm and motor output required. Maximum usable output of motors furnished are shown. In Canada, nominal motor output is also maximum usable motor output. If motors of comparable output are used, be sure to keep within the service factor limitations outlined on the motor nameplate.

NOTE – Units equipped with Single Zone VAV Supply Fan option are limited to a motor service factor of 1.0.

SPECIFICATIONS

8.5 TON

General Data		Nominal Tonnage	8.5 Ton	8.5 Ton	8.5 Ton	8.5 Ton
		Model Number	KCB102S4B	KCB102S4M	KCA102H4B	KCA102H4M
		Efficiency Type	Standard	Standard	High	High
		Blower Type	CAV (Constant Air Volume)	Single Zone VAV Supply Fan	CAV (Constant Air Volume)	Single Zone VAV Supply Fan
Cooling Performance	Gross Cooling Capacity - Btuh		99,600	99,600	103,800	103,800
	¹ Net Cooling Capacity - Btuh		97,000	97,000	100,000	100,000
	AHRI Rated Air Flow - cfm		2800	2800	3400	3400
	Total Unit Power - kW		8.7	8.7	8.1	8.1
	¹ EER (Btuh/Watt)		11.2	11.2	12.4	12.4
	¹ IEER (Btuh/Watt)		12.9	13.8	12.9	14.0
Refrigerant Charge	Refrigerant Type		R-410A	R-410A	R-410A	R-410A
	Eco-Last™ Coil System	Circuit 1	4 lbs. 5 oz.	4 lbs. 5 oz.	6 lbs. 8 oz.	6 lbs. 8 oz.
		Circuit 2	4 lbs. 3 oz.	4 lbs. 3 oz.	6 lbs. 12 oz.	6 lbs. 12 oz.
	Conventional Fin/Tube	Circuit 1	9 lbs. 3 oz.	9 lbs. 3 oz.	---	---
		Coil Option	Circuit 2	7 lbs. 14 oz.	7 lbs. 14 oz.	---
	Conventional Fin/Tube with Dehumidification Option	Circuit 1	9 lbs. 8 oz.	9 lbs. 8 oz.	---	---
		Circuit 2	9 lbs. 4 oz.	9 lbs. 4 oz.	---	---
Electric Heat Available - See page 14			7.5,15,22.5,30 & 45 KW			
Compressor Type (number)			Scroll (2)	Scroll (2)	Scroll (2)	Scroll (2)
Outdoor Coils	Net face area (total) - sq. ft.		20.5	20.5	28.0	28.0
	Number of rows		1 (2)	1 (2)	1	1
	Eco-Last™ (Fin/Tube) Fins per inch		23 (20)	23 (20)	20	20
Outdoor Coil Fans	Motor - (No.) hp		(2) 1/3	(2) 1/3	(2) 1/3	(2) 1/3
	Motor rpm		1075	1075	1075	1075
	Total Motor watts		740	740	800	800
	Diameter - (No.) in.		(2) 24	(2) 24	(2) 24	(2) 24
	Number of blades		3	3	3	3
	Total Air volume - cfm		8800	8800	8800	8800
Indoor Coils	Net face area (total) - sq. ft.		12.78	12.78	12.78	12.78
	Tube diameter - in.		3/8	3/8	3/8	3/8
	Number of rows		3	3	4	4
	Fins per inch		14	14	14	14
	Drain connection - Number and size		(1) 1 in. NPT coupling			
Expansion device type		Refrigerant Metering Orifice (RFC) - No Dehumidification Option Balanced port TXV, removable head - Dehumidification Option		Balance port TXV, removable head		
² Indoor Blower and Drive Selection	Nominal motor output		2 hp, 3 hp, 5 hp			
	Maximum usable motor output (US Only)		2.3 hp, 3.45 hp, 5.75 hp			
	Motor - Drive kit number		2 hp Kit 1 590-890 rpm Kit 2 800-1105 rpm Kit 3 795-1195 rpm 3 hp Kit 7 730-970 rpm Kit 8 940-1200 rpm Kit 9 1015-1300 rpm 5 hp Kit 10 900-1135 rpm Kit 11 1040-1315 rpm Kit 12 1125-1425 rpm			
Blower wheel nominal diameter x width - in.			(1) 15 X 15	(1) 15 X 15	(1) 15 X 15	(1) 15 X 15
Filters	Type of filter		Disposable			
	Number and size - in.		(4) 20 x 25 x 2			
Electrical characteristics			208/230V, 460V or 575V - 60 hertz - 3 phase			

NOTE - Net capacity includes evaporator blower motor heat deduction. Gross capacity does not include evaporator blower motor heat deduction.

1 AHRI Certified to AHRI Standard 340/360; 95°F outdoor air temperature and 80°F db/67°F wb entering evaporator air; minimum external duct static pressure.

2 Using total air volume and system static pressure requirements determine from blower performance tables rpm and motor output required. Maximum usable output of motors furnished are shown. In Canada, nominal motor output is also maximum usable motor output. If motors of comparable output are used, be sure to keep within the service factor limitations outlined on the motor nameplate.

NOTE – Units equipped with Single Zone VAV Supply Fan option are limited to a motor service factor of 1.0.

SPECIFICATIONS

10 TON

General Data		Nominal Tonnage	10 Ton	10 Ton	10 Ton	10 Ton
Model Number			KCB120S4B	KCB120S4M	KCA120H4B	KCA120H4M
Efficiency Type			Standard	Standard	High	High
Blower Type			CAV (Constant Air Volume)	Single Zone VAV Supply Fan	CAV (Constant Air Volume)	Single Zone VAV Supply Fan
Cooling Performance	Gross Cooling Capacity - Btuh		118,000	118,000	122,000	122,000
	¹ Net Cooling Capacity - Btuh		115,000	115,000	118,000	118,000
	AHRI Rated Air Flow - cfm		3000	3000	3600	3300
	Total Unit Power - kW		10.3	10.3	9.7	9.7
	¹ EER (Btuh/Watt)		11.2	11.2	12.2	12.2
	¹ IEER (Btuh/Watt)		12.9	13.6	13.2	14.0
Refrigerant Charge	Refrigerant Type		R-410A	R-410A	R-410A	R-410A
	Eco-Last Coil System	Circuit 1	5 lbs. 7 oz.	5 lbs. 7 oz.	7 lbs. 4 oz.	7 lbs. 4 oz.
		Circuit 2	5 lbs. 12 oz.	5 lbs. 12 oz.	7 lbs. 8 oz.	7 lbs. 8 oz.
	Conventional Fin/Tube Coil Option	Circuit 1	9 lbs. 15 oz.	9 lbs. 15 oz.	---	---
		Circuit 2	9 lbs. 1 oz.	9 lbs. 1 oz.	---	---
	Conventional Fin/Tube with Dehumidification Option	Circuit 1	10 lbs. 8 oz.	10 lbs. 8 oz.	---	---
		Circuit 2	8 lbs. 0 oz.	8 lbs. 0 oz.	---	---
	Electric Heat Available - See page 14			15, 22.5, 30, 45 & 60 KW		
Compressor Type (number)			Scroll (2)	Scroll (2)	Scroll (2)	Scroll (2)
Outdoor Coils (Fin/Tube)	Net face area (total) - sq. ft.		28.0	28.0	28.0	28.0
	Number of rows		1(2)	1 (2)	1	1
	Eco-Last™ Fins per inch		23 (20)	23 (20)	20	20
Outdoor Coil Fans	Motor - (No.) hp		(2) 1/3	(2) 1/3	(2) 1/3	(2) 1/3
	Motor rpm		1075	1075	1075	1075
	Total Motor watts		690	690	800	800
	Diameter - (No.) in.		(2) 24	(2) 24	(2) 24	(2) 24
	Number of blades		3	3	3	3
	Total Air volume - cfm		9300	9300	8800	8800
Indoor Coils	Net face area (total) - sq. ft.		12.78	12.78	13.54	13.54
	Tube diameter - in.		3/8	3/8	3/8	3/8
	Number of rows		4	4	4	4
	Fins per inch		14	14	14	14
	Drain connection - Number and size		(1) 1 in. NPT coupling			
	Expansion device type		Refrigerant Metering Orifice (RFC) - No Dehumidification Option Balanced port TXV, removable head - Dehumidification Option		Balance port TXV, removable head	
² Indoor Blower and Drive Selection	Nominal motor output		2 hp, 3 hp, 5 hp			
	Maximum usable motor output (US Only)		2.3 hp, 3.45 hp, 5.75 hp			
	Motor - Drive kit number		2 hp Kit 1 590-890 rpm Kit 2 800-1105 rpm Kit 3 795-1195 rpm 3 hp Kit 7 730-970 rpm Kit 8 940-1200 rpm Kit 9 1015-1300 rpm 5 hp Kit 10 900-1135 rpm Kit 11 1040-1315 rpm Kit 12 1125-1425 rpm			
Blower wheel nominal diameter x width - in.			(1) 15 X 15	(1) 15 X 15	(1) 15 X 15	(1) 15 X 15
Filters	Type of filter		Disposable			
	Number and size - in.		(4) 20 x 25 x 2			
Electrical characteristics			208/230V, 460V or 575V - 60 hertz - 3 phase			

NOTE - Net capacity includes evaporator blower motor heat deduction. Gross capacity does not include evaporator blower motor heat deduction.

¹ AHRI Certified to AHRI Standard 340/360; 95°F outdoor air temperature and 80°F db/67°F wb entering evaporator air; minimum external duct static pressure.

² Using total air volume and system static pressure requirements determine from blower performance tables rpm and motor output required. Maximum usable output of motors furnished are shown. In Canada, nominal motor output is also maximum usable motor output. If motors of comparable output are used, be sure to keep within the service factor limitations outlined on the motor nameplate.

NOTE – Units equipped with Single Zone VAV Supply Fan option are limited to a motor service factor of 1.0.

SPECIFICATIONS

12.5 TON

General Data		Nominal Tonnage	12.5 Ton	12.5 Ton
		Model Number	KCB150S4B	KCB150S4M
		Efficiency Type	Standard	Standard
		Blower Type	CAV (Constant Air Volume)	Single Zone VAV Supply Fan
Cooling Performance	Gross Cooling Capacity - Btuh		143,000	143,000
	¹ Net Cooling Capacity - Btuh		138,000	138,000
	AHRI Rated Air Flow - cfm		3950	3950
	Total Unit Power - kW		12.6	12.6
	¹ EER (Btuh/Watt)		11.0	11.0
	¹ IEER (Btuh/Watt)		12.4	13.5
Refrigerant Charge	Refrigerant Type		R-410A	R-410A
	Fin/Tube Coil	Circuit 1	14 lbs. 0 oz.	14 lbs. 0 oz.
		Circuit 2	13 lbs. 8 oz.	13 lbs. 8 oz.
	Fin/Tube Coil with Dehumidification Option	Circuit 1	14 lbs. 6 oz.	14 lbs. 6 oz.
		Circuit 2	13 lbs. 8 oz.	13 lbs. 8 oz.
Electric Heat Available - See page 14			15, 22.5, 30, 45 & 60 KW	
Compressor Type (number)			Scroll (2)	Scroll (2)
Outdoor Coils	Net face area (total) - sq. ft.		28.0	28.0
	Number of rows		3	3
	Fins per inch		20	20
Outdoor Coil Fans	Motor - (No.) hp		(2) 1/2	(2) 1/2
	Motor rpm		1075	1075
	Total Motor watts		1050	1050
	Diameter - (No.) in.		(2) 24	(2) 24
	Number of blades		3	3
	Total Air volume - cfm		9700	9700
Indoor Coils	Net face area (total) - sq. ft.		13.54	13.54
	Tube diameter - in.		3/8	3/8
	Number of rows		4	4
	Fins per inch		14	14
	Drain connection - Number and size		(1) 1 in. NPT coupling	
Expansion device type		Balance port TXV, removable head		
² Indoor Blower and Drive Selection	Nominal motor output		2 hp, 3 hp, 5 hp	
	Maximum usable motor output (US Only)		2.3 hp, 3.45 hp, 5.75 hp	
	Motor - Drive kit number		2 hp Kit 1 590-890 rpm Kit 2 800-1105 rpm Kit 3 795-1195 rpm	
			3 hp Kit 7 730-970 rpm Kit 8 940-1200 rpm Kit 9 1015-1300 rpm	
Blower wheel nominal diameter x width - in.		5 hp Kit 10 900-1135 rpm Kit 11 1040-1315 rpm Kit 12 1125-1425 rpm		
		(1) 15 X 15	(1) 15 X 15	
Filters	Type of filter		Disposable	
	Number and size - in.		(4) 20 x 25 x 2	
Electrical characteristics			208/230V, 460V or 575V - 60 hertz - 3 phase	

NOTE - Net capacity includes evaporator blower motor heat deduction. Gross capacity does not include evaporator blower motor heat deduction.

¹ AHRI Certified to AHRI Standard 340/360; 95°F outdoor air temperature and 80°F db/67°F wb entering evaporator air; minimum external duct static pressure.

² Using total air volume and system static pressure requirements determine from blower performance tables rpm and motor output required. Maximum usable output of motors furnished are shown. In Canada, nominal motor output is also maximum usable motor output. If motors of comparable output are used, be sure to keep within the service factor limitations outlined on the motor nameplate.

NOTE – Units equipped with Single Zone VAV Supply Fan option are limited to a motor service factor of 1.0.

RATINGS

NOTE – For Temperatures and Capacities not shown in tables, see bulletin – Cooling Unit Rating Table Correction Factor Data in Miscellaneous Engineering Data section.

7.5 TON STANDARD EFFICIENCY KCB092S4B (1ST STAGE) - CONSTANT AIR VOLUME

Entering Wet Bulb Temperature	Total Air Volume	Outdoor Air Temperature Entering Outdoor Coil																			
		65°F					75°F					85°F					95°F				
		Total Cool Cap.	Comp. Motor Input	Sensible To Total Ratio (S/T)			Total Cool Cap.	Comp. Motor Input	Sensible To Total Ratio (S/T)			Total Cool Cap.	Comp. Motor Input	Sensible To Total Ratio (S/T)			Total Cool Cap.	Comp. Motor Input	Sensible To Total Ratio (S/T)		
				Dry Bulb					Dry Bulb					Dry Bulb					Dry Bulb		
cfm	kBtuh	kW	75°F	80°F	85°F	kBtuh	kW	75°F	80°F	85°F	kBtuh	kW	75°F	80°F	85°F	kBtuh	kW	75°F	80°F	85°F	
63°F	2400	63.6	2.73	0.66	0.77	0.90	60.9	3.06	0.66	0.78	0.91	57.8	3.43	0.67	0.80	0.93	54.5	3.86	0.68	0.82	0.96
	3000	67.1	2.76	0.69	0.83	0.96	64.3	3.08	0.70	0.84	0.98	61.1	3.45	0.71	0.86	0.99	57.6	3.88	0.72	0.88	1.00
	3600	70.2	2.78	0.72	0.88	1.00	67.1	3.10	0.73	0.89	1.00	63.7	3.47	0.74	0.91	1.00	60.0	3.90	0.76	0.94	1.00
67°F	2400	66.8	2.76	0.53	0.64	0.74	64.0	3.08	0.54	0.64	0.75	60.9	3.45	0.54	0.65	0.76	57.4	3.88	0.54	0.66	0.78
	3000	70.7	2.79	0.55	0.67	0.79	67.5	3.10	0.56	0.67	0.81	64.1	3.47	0.56	0.68	0.82	60.5	3.91	0.56	0.70	0.85
	3600	73.5	2.80	0.57	0.70	0.84	70.2	3.12	0.57	0.71	0.86	66.6	3.49	0.58	0.72	0.88	62.6	3.92	0.58	0.74	0.90
71°F	2400	69.7	2.78	0.42	0.52	0.61	66.8	3.10	0.42	0.52	0.62	63.6	3.47	0.41	0.52	0.63	60.1	3.90	0.40	0.53	0.64
	3000	73.9	2.81	0.43	0.54	0.65	70.6	3.12	0.43	0.54	0.65	67.1	3.50	0.42	0.55	0.66	63.3	3.93	0.41	0.55	0.68
	3600	77.0	2.83	0.44	0.56	0.68	73.5	3.14	0.44	0.56	0.69	69.6	3.51	0.41	0.57	0.70	65.6	3.95	0.42	0.57	0.72

7.5 TON STANDARD EFFICIENCY KCB092S4B (2ND STAGE) - CONSTANT AIR VOLUME

Entering Wet Bulb Temperature	Total Air Volume	Outdoor Air Temperature Entering Outdoor Coil																			
		85°F					95°F					105°F					115°F				
		Total Cool Cap.	Comp. Motor Input	Sensible To Total Ratio (S/T)			Total Cool Cap.	Comp. Motor Input	Sensible To Total Ratio (S/T)			Total Cool Cap.	Comp. Motor Input	Sensible To Total Ratio (S/T)			Total Cool Cap.	Comp. Motor Input	Sensible To Total Ratio (S/T)		
				Dry Bulb					Dry Bulb					Dry Bulb					Dry Bulb		
cfm	kBtuh	kW	75°F	80°F	85°F	kBtuh	kW	75°F	80°F	85°F	kBtuh	kW	75°F	80°F	85°F	kBtuh	kW	75°F	80°F	85°F	
63°F	2400	86.0	5.76	0.68	0.82	0.96	80.6	6.50	0.69	0.84	0.98	74.8	7.36	0.71	0.87	1.00	68.6	8.33	0.73	0.90	1.00
	3000	90.8	5.80	0.73	0.89	1.00	85.0	6.54	0.74	0.92	1.00	78.8	7.40	0.76	0.95	1.00	72.2	8.38	0.79	0.98	1.00
	3600	94.4	5.82	0.77	0.95	1.00	88.3	6.57	0.79	0.98	1.00	82.0	7.43	0.82	0.99	1.00	75.5	8.42	0.85	1.00	1.00
67°F	2400	90.7	5.79	0.54	0.66	0.78	85.2	6.54	0.54	0.67	0.80	79.3	7.40	0.55	0.69	0.83	72.7	8.38	0.56	0.70	0.86
	3000	96.0	5.83	0.57	0.70	0.85	89.9	6.58	0.57	0.72	0.88	83.5	7.45	0.58	0.74	0.91	76.7	8.43	0.59	0.77	0.95
	3600	99.7	5.85	0.59	0.75	0.92	93.4	6.61	0.60	0.77	0.95	86.6	7.48	0.61	0.79	0.98	79.3	8.47	0.63	0.83	1.00
71°F	2400	95.0	5.82	0.41	0.53	0.64	89.5	6.58	0.41	0.53	0.65	83.3	7.44	0.4	0.54	0.66	76.7	8.43	0.40	0.55	0.68
	3000	100.7	5.86	0.43	0.56	0.68	94.5	6.62	0.42	0.56	0.70	87.9	7.49	0.41	0.57	0.72	80.8	8.48	0.41	0.58	0.74
	3600	104.7	5.89	0.43	0.58	0.72	98.1	6.65	0.43	0.59	0.74	91.2	7.52	0.43	0.60	0.77	83.8	8.52	0.43	0.62	0.80

7.5 TON HIGH EFFICIENCY KCA092H4B (1ST STAGE) - CONSTANT AIR VOLUME

Entering Wet Bulb Temperature	Total Air Volume	Outdoor Air Temperature Entering Outdoor Coil																			
		65°F					75°F					85°F					95°F				
		Total Cool Cap.	Comp. Motor Input	Sensible To Total Ratio (S/T)			Total Cool Cap.	Comp. Motor Input	Sensible To Total Ratio (S/T)			Total Cool Cap.	Comp. Motor Input	Sensible To Total Ratio (S/T)			Total Cool Cap.	Comp. Motor Input	Sensible To Total Ratio (S/T)		
				Dry Bulb					Dry Bulb					Dry Bulb					Dry Bulb		
cfm	kBtuh	kW	75°F	80°F	85°F	kBtuh	kW	75°F	80°F	85°F	kBtuh	kW	75°F	80°F	85°F	kBtuh	kW	75°F	80°F	85°F	
63°F	2400	48.2	1.95	0.67	0.80	0.95	46.2	2.21	0.67	0.81	0.97	43.9	2.49	0.68	0.83	0.99	41.7	2.81	0.69	0.85	1.00
	3000	50.8	1.96	0.71	0.88	1.00	48.6	2.21	0.72	0.90	1.00	46.2	2.49	0.74	0.92	1.00	43.7	2.81	0.76	0.96	1.00
	3600	52.8	1.96	0.76	0.96	1.00	50.4	2.22	0.78	0.98	1.00	48.0	2.50	0.80	1.00	1.00	45.6	2.81	0.82	1.00	1.00
67°F	2400	51.1	1.96	0.53	0.65	0.76	48.9	2.21	0.53	0.65	0.78	46.6	2.49	0.54	0.66	0.79	44.1	2.81	0.54	0.67	0.81
	3000	53.8	1.97	0.55	0.69	0.84	51.4	2.22	0.56	0.70	0.86	48.9	2.50	0.57	0.71	0.88	46.4	2.82	0.58	0.73	0.92
	3600	55.7	1.97	0.59	0.74	0.91	53.3	2.22	0.60	0.76	0.95	50.6	2.50	0.61	0.78	0.97	47.7	2.82	0.61	0.80	1.00
71°F	2400	54.2	1.97	0.41	0.52	0.62	51.9	2.22	0.41	0.52	0.63	49.5	2.50	0.41	0.52	0.64	47.1	2.82	0.41	0.53	0.65
	3000	56.7	1.98	0.41	0.54	0.67	54.3	2.23	0.42	0.55	0.68	51.7	2.51	0.42	0.56	0.69	48.9	2.82	0.42	0.57	0.71
	3600	58.6	1.98	0.43	0.57	0.71	56.1	2.23	0.44	0.58	0.73	53.4	2.51	0.43	0.60	0.75	50.6	2.83	0.43	0.61	0.78

7.5 TON HIGH EFFICIENCY KCA092H4B (2ND STAGE) - CONSTANT AIR VOLUME

Entering Wet Bulb Temperature	Total Air Volume	Outdoor Air Temperature Entering Outdoor Coil																			
		85°F					95°F					105°F					115°F				
		Total Cool Cap.	Comp. Motor Input	Sensible To Total Ratio (S/T)			Total Cool Cap.	Comp. Motor Input	Sensible To Total Ratio (S/T)			Total Cool Cap.	Comp. Motor Input	Sensible To Total Ratio (S/T)			Total Cool Cap.	Comp. Motor Input	Sensible To Total Ratio (S/T)		
				Dry Bulb					Dry Bulb					Dry Bulb					Dry Bulb		
cfm	kBtuh	kW	75°F	80°F	85°F	kBtuh	kW	75°F	80°F	85°F	kBtuh	kW	75°F	80°F	85°F	kBtuh	kW	75°F	80°F	85°F	
63°F	2400	87.9	4.98	0.68	0.83	0.99	83.4	5.62	0.69	0.85	1.00	78.4	6.36	0.71	0.88	1.00	73.1	7.23	0.73	0.92	1.00
	3000	92.4	4.99	0.74	0.92	1.00	87.6	5.63	0.76	0.96	1.00	82.3	6.37	0.78	0.98	1.00	76.8	7.22	0.80	1.00	1.00
	3600	96.0	5.00	0.80	1.00	1.00	91.2	5.64	0.82	1.00	1.00	86.4	6.37	0.85	1.00	1.00	81.2	7.22	0.88	1.00	1.00
67°F	2400	93.3	4.99	0.54	0.66	0.79	88.4	5.63	0.54	0.67	0.81	83.3	6.37	0.55	0.68	0.84	78.0	7.23	0.56	0.71	0.88
	3000	97.9	5.00	0.57	0.71	0.88	93.0	5.64	0.58	0.73	0.91	87.2	6.37	0.59	0.75	0.95	81.1	7.22	0.59	0.78	0.99
	3600	101.4	5.01	0.61	0.77	0.97	95.6	5.64	0.61	0.79	1.00	90.0	6.38	0.62	0.82	1.00	83.6	7.22	0.64	0.86	1.00
71°F	2400	99.1	5.00	0.41	0.52	0.64	94.0	5.64	0.41	0.53	0.65	88.6	6.37	0.4	0.54	0.66	82.7	7.22	0.41	0.55	0.68
	3000	103.3	5.01	0.42	0.56	0.69	98.0	5.65	0.42	0.57	0.71	92.2	6.38	0.42	0.58	0.73	86.0	7.23	0.43	0.59	0.75
	3600	106.9	5.02	0.44	0.60	0.75	101.2	5.66	0.43	0.60	0.77	95.0	6.38	0.44	0.61	0.8	88.3	7.22	0.44	0.63	0.84

RATINGS

NOTE – For Temperatures and Capacities not shown in tables, see bulletin – Cooling Unit Rating Table Correction Factor Data in Miscellaneous Engineering Data section.

8.5 TON STANDARD EFFICIENCY KCB102S4B (1ST STAGE) - CONSTANT AIR VOLUME

Entering Wet Bulb Temperature	Total Air Volume	Outdoor Air Temperature Entering Outdoor Coil																			
		65°F					75°F					85°F					95°F				
		Total Cool Cap.	Comp. Motor Input	Sensible To Total Ratio (S/T)			Total Cool Cap.	Comp. Motor Input	Sensible To Total Ratio (S/T)			Total Cool Cap.	Comp. Motor Input	Sensible To Total Ratio (S/T)			Total Cool Cap.	Comp. Motor Input	Sensible To Total Ratio (S/T)		
				Dry Bulb					Dry Bulb					Dry Bulb					Dry Bulb		
cfm	kBtuh	kW	75°F	80°F	85°F	kBtuh	kW	75°F	80°F	85°F	kBtuh	kW	75°F	80°F	85°F	kBtuh	kW	75°F	80°F	85°F	
63°F	2720	57.3	2.49	0.63	0.76	0.91	53.8	2.78	0.63	0.77	0.93	50.0	3.10	0.63	0.79	0.96	46.1	3.49	0.63	0.81	0.99
	3400	61.1	2.51	0.67	0.83	0.99	57.4	2.79	0.67	0.85	1.00	53.3	3.11	0.68	0.87	1.00	49.0	3.49	0.69	0.90	1.00
	4080	63.9	2.51	0.71	0.90	1.00	59.9	2.79	0.72	0.92	1.00	55.7	3.12	0.73	0.95	1.00	51.1	3.50	0.75	0.98	1.00
67°F	2720	60.9	2.50	0.50	0.61	0.73	57.2	2.79	0.50	0.61	0.73	53.4	3.11	0.49	0.61	0.75	49.3	3.49	0.49	0.62	0.76
	3400	64.9	2.50	0.53	0.65	0.79	61.0	2.79	0.52	0.65	0.81	56.8	3.12	0.52	0.66	0.83	52.4	3.50	0.52	0.67	0.86
	4080	67.8	2.52	0.55	0.69	0.86	63.7	2.81	0.55	0.69	0.88	59.4	3.13	0.55	0.71	0.91	54.7	3.51	0.55	0.73	0.94
71°F	2720	64.2	2.51	0.39	0.49	0.59	60.5	2.80	0.38	0.49	0.59	56.5	3.12	0.37	0.48	0.59	52.4	3.51	0.35	0.48	0.60
	3400	68.4	2.52	0.40	0.52	0.63	64.4	2.80	0.39	0.52	0.63	60.1	3.13	0.38	0.51	0.64	55.6	3.52	0.37	0.51	0.65
	4080	71.4	2.53	0.41	0.54	0.66	67.3	2.82	0.41	0.54	0.67	62.8	3.14	0.40	0.54	0.69	58.0	3.52	0.39	0.54	0.70

8.5 TON STANDARD EFFICIENCY KCB102S4B (2ND STAGE) - CONSTANT AIR VOLUME

Entering Wet Bulb Temperature	Total Air Volume	Outdoor Air Temperature Entering Outdoor Coil																			
		85°F					95°F					105°F					115°F				
		Total Cool Cap.	Comp. Motor Input	Sensible To Total Ratio (S/T)			Total Cool Cap.	Comp. Motor Input	Sensible To Total Ratio (S/T)			Total Cool Cap.	Comp. Motor Input	Sensible To Total Ratio (S/T)			Total Cool Cap.	Comp. Motor Input	Sensible To Total Ratio (S/T)		
				Dry Bulb					Dry Bulb					Dry Bulb					Dry Bulb		
cfm	kBtuh	kW	75°F	80°F	85°F	kBtuh	kW	75°F	80°F	85°F	kBtuh	kW	75°F	80°F	85°F	kBtuh	kW	75°F	80°F	85°F	
63°F	2720	95.0	6.52	0.67	0.82	0.96	87.4	7.34	0.67	0.83	0.99	79.3	8.28	0.68	0.85	1.00	70.8	9.42	0.69	0.88	1.00
	3400	101.3	6.54	0.72	0.89	1.00	93.1	7.35	0.73	0.91	1.00	84.6	8.30	0.74	0.94	1.00	75.4	9.43	0.76	0.98	1.00
	4080	105.8	6.55	0.77	0.96	1.00	97.1	7.37	0.78	0.98	1.00	88.4	8.31	0.80	1.00	1.00	79.8	9.44	0.83	1.00	1.00
67°F	2720	101.4	6.54	0.52	0.65	0.78	93.5	7.34	0.52	0.66	0.80	85.3	8.30	0.50	0.66	0.82	76.5	9.43	0.50	0.67	0.84
	3400	108.0	6.56	0.55	0.70	0.85	99.6	7.37	0.55	0.71	0.87	90.8	8.31	0.55	0.72	0.90	81.5	9.43	0.54	0.74	0.94
	4080	112.7	6.57	0.58	0.75	0.92	103.9	7.37	0.58	0.76	0.95	94.8	8.33	0.58	0.78	0.98	85.1	9.46	0.59	0.81	1.00
71°F	2720	107.3	6.56	0.38	0.52	0.63	99.5	7.37	0.37	0.51	0.64	91.0	8.31	0.35	0.50	0.64	82.1	9.45	0.33	0.49	0.65
	3400	114.3	6.58	0.40	0.54	0.68	105.7	7.39	0.39	0.54	0.69	96.6	8.34	0.37	0.54	0.70	87.2	9.46	0.35	0.54	0.72
	4080	119.3	6.60	0.41	0.58	0.73	110.2	7.40	0.40	0.58	0.74	100.8	8.36	0.39	0.58	0.76	90.9	9.49	0.38	0.59	0.78

8.5 TON HIGH EFFICIENCY KCA102H4B (1ST STAGE) - CONSTANT AIR VOLUME

Entering Wet Bulb Temperature	Total Air Volume	Outdoor Air Temperature Entering Outdoor Coil																			
		65°F					75°F					85°F					95°F				
		Total Cool Cap.	Comp. Motor Input	Sensible To Total Ratio (S/T)			Total Cool Cap.	Comp. Motor Input	Sensible To Total Ratio (S/T)			Total Cool Cap.	Comp. Motor Input	Sensible To Total Ratio (S/T)			Total Cool Cap.	Comp. Motor Input	Sensible To Total Ratio (S/T)		
				Dry Bulb					Dry Bulb					Dry Bulb					Dry Bulb		
cfm	kBtuh	kW	75°F	80°F	85°F	kBtuh	kW	75°F	80°F	85°F	kBtuh	kW	75°F	80°F	85°F	kBtuh	kW	75°F	80°F	85°F	
63°F	2720	53.6	2.17	0.61	0.76	0.95	50.7	2.45	0.62	0.78	0.98	47.7	2.77	0.62	0.8	1.00	44.6	3.13	0.63	0.83	1.00
	3400	56.5	2.18	0.66	0.87	1.00	53.5	2.46	0.66	0.89	1.00	50.3	2.78	0.68	0.93	1.00	47.1	3.13	0.70	0.97	1.00
	4080	58.7	2.18	0.72	0.97	1.00	55.6	2.47	0.74	1.00	1.00	52.4	2.78	0.76	1.00	1.00	49.4	3.14	0.78	1.00	1.00
67°F	2720	57.0	2.18	0.48	0.59	0.71	54.1	2.46	0.49	0.60	0.73	51.0	2.78	0.48	0.61	0.75	47.7	3.14	0.48	0.61	0.78
	3400	60.0	2.19	0.51	0.64	0.82	56.8	2.47	0.51	0.64	0.84	53.6	2.78	0.52	0.66	0.88	50.1	3.14	0.52	0.67	0.92
	4080	62.2	2.19	0.54	0.69	0.93	58.9	2.48	0.55	0.71	0.96	55.5	2.79	0.55	0.73	0.99	51.8	3.14	0.55	0.76	1.00
71°F	2720	60.4	2.19	0.37	0.47	0.57	57.5	2.47	0.37	0.48	0.58	54.2	2.78	0.36	0.47	0.59	50.8	3.14	0.35	0.47	0.59
	3400	63.5	2.20	0.38	0.50	0.62	60.2	2.48	0.38	0.51	0.63	56.8	2.79	0.37	0.51	0.64	53.3	3.15	0.37	0.52	0.65
	4080	65.6	2.20	0.39	0.53	0.67	62.3	2.49	0.40	0.54	0.68	58.9	2.80	0.39	0.54	0.70	55.0	3.15	0.39	0.55	0.73

8.5 TON HIGH EFFICIENCY KCA102H4B (2ND STAGE) - CONSTANT AIR VOLUME

Entering Wet Bulb Temperature	Total Air Volume	Outdoor Air Temperature Entering Outdoor Coil																			
		85°F					95°F					105°F					115°F				
		Total Cool Cap.	Comp. Motor Input	Sensible To Total Ratio (S/T)			Total Cool Cap.	Comp. Motor Input	Sensible To Total Ratio (S/T)			Total Cool Cap.	Comp. Motor Input	Sensible To Total Ratio (S/T)			Total Cool Cap.	Comp. Motor Input	Sensible To Total Ratio (S/T)		
				Dry Bulb					Dry Bulb					Dry Bulb					Dry Bulb		
cfm	kBtuh	kW	75°F	80°F	85°F	kBtuh	kW	75°F	80°F	85°F	kBtuh	kW	75°F	80°F	85°F	kBtuh	kW	75°F	80°F	85°F	
63°F	2720	98.9	5.54	0.70	0.85	1.00	92.5	6.27	0.71	0.87	1.00	85.7	7.10	0.71	0.90	1.00	78.6	8.09	0.73	0.94	1.00
	3400	104.2	5.56	0.76	0.95	1.00	97.5	6.27	0.77	0.98	1.00	90.4	7.11	0.79	1.00	1.00	83.6	8.08	0.82	1.00	1.00
	4080	108.6	5.56	0.82	1.00	1.00	102.3	6.28	0.84	1.00	1.00	95.9	7.12	0.87	1.00	1.00	88.9	8.08	0.91	1.00	1.00
67°F	2720	105.6	5.56	0.53	0.67	0.81	98.9	6.28	0.53	0.68	0.83	91.8	7.11	0.54	0.69	0.87	84.4	8.08	0.55	0.71	0.90
	3400	110.9	5.57	0.58	0.74	0.91	103.8	6.29	0.59	0.75	0.94	96.4	7.12	0.59	0.77	0.97	88.5	8.08	0.59	0.79	1.00
	4080	114.8	5.58	0.61	0.80	0.99	107.2	6.30	0.62	0.82	1.00	99.6	7.12	0.63	0.85	1.00	91.5	8.08	0.63	0.88	1.00
71°F	2720	112.1	5.57	0.40	0.53	0.65	105.2	6.29	0.39	0.53	0.66	98.1	7.12	0.38	0.53	0.67	90.3	8.08	0.38	0.54	0.69
	3400	117.6	5.59	0.42	0.57	0.72	110.4	6.30	0.41	0.58	0.73	102.7	7.12	0.41	0.58	0.75	94.3	8.08	0.40	0.59	0.77
	4080	121.7	5.60	0.44	0.61	0.77	113.9	6.31	0.43	0.61	0.79	105.9	7.13	0.42	0.62	0.83	97.4	8.08	0.43	0.63	0.86

RATINGS

NOTE – For Temperatures and Capacities not shown in tables, see bulletin – Cooling Unit Rating Table Correction Factor Data in Miscellaneous Engineering Data section.

10 TON STANDARD EFFICIENCY KCB120S4B (1ST STAGE) - CONSTANT AIR VOLUME

Entering Wet Bulb Temperature	Total Air Volume	Outdoor Air Temperature Entering Outdoor Coil																			
		65°F					75°F					85°F					95°F				
		Total Cool Cap.	Comp. Motor Input	Sensible To Total Ratio (S/T)			Total Cool Cap.	Comp. Motor Input	Sensible To Total Ratio (S/T)			Total Cool Cap.	Comp. Motor Input	Sensible To Total Ratio (S/T)			Total Cool Cap.	Comp. Motor Input	Sensible To Total Ratio (S/T)		
				Dry Bulb					Dry Bulb					Dry Bulb					Dry Bulb		
cfm	kBtuh	kW	75°F	80°F	85°F	kBtuh	kW	75°F	80°F	85°F	kBtuh	kW	75°F	80°F	85°F	kBtuh	kW	75°F	80°F	85°F	
63°F	3200	62.2	2.85	0.66	0.80	0.94	58.1	3.21	0.66	0.81	0.96	53.6	3.62	0.66	0.82	0.98	49.0	4.09	0.66	0.84	1.00
	4000	66.2	2.86	0.71	0.87	1.00	61.8	3.23	0.71	0.88	1.00	57.2	3.65	0.71	0.90	1.00	52.4	4.11	0.73	0.93	1.00
	4800	69.2	2.89	0.75	0.94	1.00	64.7	3.24	0.76	0.96	1.00	59.9	3.66	0.78	0.98	1.00	54.9	4.14	0.79	1.00	1.00
67°F	3200	66.8	2.87	0.53	0.64	0.76	62.4	3.23	0.52	0.64	0.77	57.9	3.65	0.51	0.64	0.78	53.1	4.12	0.50	0.64	0.80
	4000	70.8	2.88	0.55	0.69	0.83	66.2	3.25	0.55	0.69	0.85	61.3	3.67	0.54	0.69	0.86	56.3	4.15	0.54	0.70	0.89
	4800	73.7	2.89	0.58	0.73	0.90	68.8	3.27	0.57	0.74	0.92	63.9	3.69	0.58	0.75	0.94	58.7	4.17	0.57	0.77	0.97
71°F	3200	71.3	2.89	0.41	0.52	0.62	66.9	3.26	0.39	0.51	0.62	62.1	3.68	0.37	0.50	0.62	57.1	4.16	0.36	0.49	0.63
	4000	75.4	2.90	0.42	0.55	0.67	70.7	3.28	0.40	0.54	0.67	65.7	3.70	0.39	0.54	0.68	60.3	4.18	0.38	0.53	0.68
	4800	78.4	2.92	0.43	0.58	0.71	73.4	3.29	0.42	0.57	0.72	68.2	3.72	0.41	0.57	0.73	62.8	4.20	0.40	0.57	0.75

10 TON STANDARD EFFICIENCY KCB120S4B (2ND STAGE) - CONSTANT AIR VOLUME

Entering Wet Bulb Temperature	Total Air Volume	Outdoor Air Temperature Entering Outdoor Coil																			
		85°F					95°F					105°F					115°F				
		Total Cool Cap.	Comp. Motor Input	Sensible To Total Ratio (S/T)			Total Cool Cap.	Comp. Motor Input	Sensible To Total Ratio (S/T)			Total Cool Cap.	Comp. Motor Input	Sensible To Total Ratio (S/T)			Total Cool Cap.	Comp. Motor Input	Sensible To Total Ratio (S/T)		
				Dry Bulb					Dry Bulb					Dry Bulb					Dry Bulb		
cfm	kBtuh	kW	75°F	80°F	85°F	kBtuh	kW	75°F	80°F	85°F	kBtuh	kW	75°F	80°F	85°F	kBtuh	kW	75°F	80°F	85°F	
63°F	3200	114.0	7.38	0.68	0.83	0.98	104.2	8.32	0.68	0.85	1.00	93.9	9.38	0.68	0.87	1.00	83.2	10.57	0.69	0.91	1.00
	4000	121.0	7.42	0.73	0.92	1.00	111.1	8.38	0.74	0.94	1.00	100.5	9.44	0.76	0.97	1.00	89.4	10.64	0.78	1.00	1.00
	4800	126.9	7.46	0.79	0.99	1.00	116.4	8.42	0.81	1.00	1.00	106.5	9.50	0.83	1.00	1.00	96.0	10.71	0.86	1.00	1.00
67°F	3200	123.1	7.43	0.52	0.66	0.79	113.0	8.39	0.51	0.66	0.81	102.5	9.46	0.50	0.67	0.83	91.5	10.66	0.49	0.67	0.87
	4000	130.6	7.48	0.55	0.71	0.88	120.0	8.44	0.55	0.72	0.90	108.8	9.52	0.55	0.74	0.93	97.0	10.73	0.55	0.76	0.98
	4800	136.0	7.51	0.59	0.77	0.95	124.9	8.48	0.59	0.78	0.98	113.3	9.56	0.59	0.81	1.00	101.2	10.77	0.60	0.84	1.00
71°F	3200	131.9	7.49	0.38	0.51	0.64	121.7	8.45	0.36	0.50	0.64	110.7	9.53	0.34	0.50	0.65	99.4	10.75	0.32	0.49	0.65
	4000	139.7	7.54	0.40	0.55	0.69	128.7	8.50	0.39	0.55	0.70	117.5	9.60	0.37	0.55	0.72	105.4	10.82	0.35	0.55	0.74
	4800	145.4	7.58	0.42	0.58	0.75	134.0	8.56	0.41	0.59	0.76	122.3	9.65	0.39	0.59	0.78	109.7	10.88	0.38	0.60	0.82

10 TON HIGH EFFICIENCY KCA120H4B (1ST STAGE) - CONSTANT AIR VOLUME

Entering Wet Bulb Temperature	Total Air Volume	Outdoor Air Temperature Entering Outdoor Coil																			
		65°F					75°F					85°F					95°F				
		Total Cool Cap.	Comp. Motor Input	Sensible To Total Ratio (S/T)			Total Cool Cap.	Comp. Motor Input	Sensible To Total Ratio (S/T)			Total Cool Cap.	Comp. Motor Input	Sensible To Total Ratio (S/T)			Total Cool Cap.	Comp. Motor Input	Sensible To Total Ratio (S/T)		
				Dry Bulb					Dry Bulb					Dry Bulb					Dry Bulb		
cfm	kBtuh	kW	75°F	80°F	85°F	kBtuh	kW	75°F	80°F	85°F	kBtuh	kW	75°F	80°F	85°F	kBtuh	kW	75°F	80°F	85°F	
63°F	3200	67.0	2.76	0.66	0.80	0.95	64.0	3.14	0.67	0.81	0.97	60.6	3.55	0.68	0.83	0.99	57.1	4.01	0.68	0.85	1.00
	4000	70.5	2.80	0.71	0.88	1.00	67.2	3.17	0.72	0.90	1.00	63.7	3.58	0.73	0.93	1.00	60.1	4.05	0.75	0.96	1.00
	4800	73.1	2.82	0.77	0.96	1.00	69.8	3.19	0.78	0.98	1.00	66.1	3.60	0.80	1.00	1.00	62.6	4.07	0.82	1.00	1.00
67°F	3200	71.0	2.80	0.53	0.64	0.76	67.8	3.17	0.53	0.65	0.78	64.3	3.59	0.53	0.66	0.79	60.8	4.05	0.53	0.66	0.81
	4000	74.7	2.83	0.56	0.69	0.84	71.2	3.21	0.56	0.70	0.86	67.5	3.62	0.57	0.71	0.89	63.8	4.08	0.57	0.73	0.91
	4800	77.3	2.86	0.58	0.74	0.92	73.8	3.23	0.59	0.76	0.95	69.9	3.64	0.6	0.77	0.98	65.9	4.11	0.61	0.80	1.00
71°F	3200	75.3	2.84	0.41	0.52	0.62	71.9	3.21	0.40	0.52	0.63	68.3	3.63	0.40	0.51	0.64	64.6	4.09	0.39	0.52	0.65
	4000	78.7	2.87	0.42	0.54	0.67	75.2	3.25	0.41	0.55	0.68	71.3	3.66	0.42	0.54	0.69	67.5	4.13	0.41	0.56	0.70
	4800	81.3	2.90	0.43	0.57	0.71	77.6	3.28	0.43	0.58	0.73	73.8	3.69	0.43	0.59	0.75	69.6	4.15	0.43	0.60	0.77

10 TON HIGH EFFICIENCY KCA120H4B (2ND STAGE) - CONSTANT AIR VOLUME

Entering Wet Bulb Temperature	Total Air Volume	Outdoor Air Temperature Entering Outdoor Coil																			
		85°F					95°F					105°F					115°F				
		Total Cool Cap.	Comp. Motor Input	Sensible To Total Ratio (S/T)			Total Cool Cap.	Comp. Motor Input	Sensible To Total Ratio (S/T)			Total Cool Cap.	Comp. Motor Input	Sensible To Total Ratio (S/T)			Total Cool Cap.	Comp. Motor Input	Sensible To Total Ratio (S/T)		
				Dry Bulb					Dry Bulb					Dry Bulb					Dry Bulb		
cfm	kBtuh	kW	75°F	80°F	85°F	kBtuh	kW	75°F	80°F	85°F	kBtuh	kW	75°F	80°F	85°F	kBtuh	kW	75°F	80°F	85°F	
63°F	3200	118.9	7.05	0.68	0.84	1.00	112.1	7.96	0.69	0.86	1.00	104.6	9.00	0.71	0.89	1.00	96.6	10.17	0.72	0.93	1.00
	4000	124.9	7.11	0.74	0.94	1.00	117.7	8.03	0.76	0.97	1.00	110.0	9.05	0.78	1.00	1.00	102.2	10.23	0.80	1.00	1.00
	4800	129.9	7.17	0.80	1.00	1.00	123.0	8.08	0.83	1.00	1.00	115.7	9.12	0.86	1.00	1.00	108.0	10.30	0.90	1.00	1.00
67°F	3200	126.5	7.12	0.53	0.66	0.80	119.2	8.03	0.53	0.67	0.82	111.4	9.07	0.53	0.68	0.85	103.4	10.25	0.54	0.70	0.89
	4000	132.6	7.19	0.57	0.72	0.90	124.8	8.10	0.57	0.73	0.93	116.7	9.13	0.58	0.75	0.97	108.0	10.30	0.59	0.78	1.00
	4800	137.1	7.25	0.60	0.78	0.99	128.9	8.15	0.61	0.80	1.00	120.2	9.18	0.61	0.83	1.00	111.3	10.34	0.63	0.87	1.00
71°F	3200	134.2	7.21	0.40	0.53	0.64	126.6	8.12	0.39	0.52	0.65	118.5	9.15	0.39	0.52	0.66	110.0	10.32	0.39	0.54	0.68
	4000	140.0	7.28	0.41	0.56	0.70	132.0	8.19	0.41	0.57	0.71	123.5	9.22	0.41	0.57	0.73	114.7	10.38	0.41	0.58	0.76
	4800	144.5	7.34	0.43	0.6	0.76	136.2	8.24	0.43	0.61	0.78	127.2	9.27	0.43	0.61	0.81	117.9	10.43	0.42	0.63	0.84

RATINGS

NOTE – For Temperatures and Capacities not shown in tables, see bulletin – Cooling Unit Rating Table Correction Factor Data in Miscellaneous Engineering Data section.

12.5 TON STANDARD EFFICIENCY KCB150S4B (1ST STAGE) - CONSTANT AIR VOLUME

Entering Wet Bulb Temperature	Total Air Volume	Outdoor Air Temperature Entering Outdoor Coil																			
		65°F					75°F					85°F					95°F				
		Total Cool Cap.	Comp. Motor Input	Sensible To Total Ratio (S/T) Dry Bulb			Total Cool Cap.	Comp. Motor Input	Sensible To Total Ratio (S/T) Dry Bulb			Total Cool Cap.	Comp. Motor Input	Sensible To Total Ratio (S/T) Dry Bulb			Total Cool Cap.	Comp. Motor Input	Sensible To Total Ratio (S/T) Dry Bulb		
				75°F	80°F	85°F			75°F	80°F	85°F			75°F	80°F	85°F			75°F	80°F	85°F
		cfm	kBtuh	kW	75°F	80°F	85°F	kBtuh	kW	75°F	80°F	85°F	kBtuh	kW	75°F	80°F	85°F	kBtuh	kW	75°F	80°F
63°F	3800	76.4	3.46	0.67	0.81	0.96	72	3.83	0.67	0.82	0.98	67	4.24	0.68	0.84	0.99	61.7	4.69	0.68	0.86	1
	4400	79.6	3.47	0.71	0.86	1	74.9	3.84	0.71	0.88	1	69.9	4.25	0.71	0.9	1	64.4	4.7	0.73	0.92	1
	5000	82.3	3.49	0.74	0.91	1	77.5	3.85	0.74	0.93	1	72.2	4.26	0.76	0.95	1	66.6	4.71	0.77	0.98	1
67°F	3800	81.9	3.48	0.53	0.65	0.78	77.2	3.85	0.53	0.65	0.79	72.3	4.26	0.52	0.66	0.8	66.8	4.71	0.52	0.66	0.82
	4400	85.2	3.5	0.55	0.68	0.82	80.4	3.86	0.55	0.69	0.84	75.1	4.27	0.54	0.69	0.85	69.6	4.72	0.54	0.7	0.88
	5000	87.8	3.51	0.57	0.71	0.87	82.8	3.88	0.57	0.72	0.89	77.6	4.28	0.57	0.73	0.91	71.8	4.73	0.56	0.74	0.94
71°F	3800	87.7	3.51	0.41	0.52	0.63	83	3.87	0.4	0.52	0.63	77.8	4.28	0.38	0.52	0.64	72.3	4.73	0.37	0.51	0.64
	4400	90.7	3.52	0.42	0.54	0.66	85.8	3.89	0.41	0.54	0.66	80.6	4.29	0.4	0.54	0.67	74.8	4.74	0.38	0.53	0.68
	5000	93.6	3.54	0.43	0.56	0.69	88.3	3.9	0.41	0.56	0.7	82.9	4.3	0.41	0.56	0.71	77	4.75	0.4	0.56	0.72

12.5 TON STANDARD EFFICIENCY KCB150S4B (2ND STAGE) - CONSTANT AIR VOLUME

Entering Wet Bulb Temperature	Total Air Volume	Outdoor Air Temperature Entering Outdoor Coil																			
		85°F					95°F					105°F					115°F				
		Total Cool Cap.	Comp. Motor Input	Sensible To Total Ratio (S/T) Dry Bulb			Total Cool Cap.	Comp. Motor Input	Sensible To Total Ratio (S/T) Dry Bulb			Total Cool Cap.	Comp. Motor Input	Sensible To Total Ratio (S/T) Dry Bulb			Total Cool Cap.	Comp. Motor Input	Sensible To Total Ratio (S/T) Dry Bulb		
				75°F	80°F	85°F			75°F	80°F	85°F			75°F	80°F	85°F			75°F	80°F	85°F
		cfm	kBtuh	kW	75°F	80°F	85°F	kBtuh	kW	75°F	80°F	85°F	kBtuh	kW	75°F	80°F	85°F	kBtuh	kW	75°F	80°F
63°F	3800	146.9	9.2	0.69	0.84	0.98	135.7	10.21	0.7	0.86	1	124.2	11.34	0.7	0.88	1	111.9	12.62	0.72	0.91	1
	4400	153	9.23	0.73	0.89	1	141.3	10.23	0.74	0.91	1	129.5	11.37	0.75	0.94	1	117	12.65	0.77	0.98	1
	5000	158	9.26	0.76	0.94	1	146.2	10.27	0.77	0.97	1	134.2	11.4	0.8	0.99	1	121.8	12.67	0.82	1	1
67°F	3800	157.9	9.26	0.54	0.67	0.81	146.4	10.26	0.53	0.68	0.82	134.6	11.39	0.52	0.68	0.84	122.2	12.68	0.51	0.69	0.87
	4400	164.1	9.29	0.56	0.71	0.86	152.4	10.3	0.56	0.72	0.88	139.9	11.43	0.55	0.73	0.9	127.1	12.7	0.55	0.75	0.94
	5000	169.2	9.32	0.58	0.74	0.91	157.1	10.33	0.58	0.75	0.93	144.6	11.47	0.58	0.77	0.96	131.1	12.73	0.59	0.79	0.99
71°F	3800	169.9	9.32	0.39	0.53	0.65	158	10.34	0.38	0.52	0.65	145.8	11.47	0.37	0.52	0.66	132.7	12.74	0.35	0.51	0.67
	4400	176	9.36	0.41	0.55	0.69	163.6	10.36	0.4	0.55	0.7	151.1	11.51	0.38	0.54	0.71	137.4	12.77	0.37	0.54	0.72
	5000	180.9	9.39	0.42	0.57	0.72	168.2	10.39	0.41	0.57	0.73	155.3	11.52	0.4	0.57	0.75	141.4	12.79	0.39	0.58	0.77

RATINGS

NOTE – For Temperatures and Capacities not shown in tables, see bulletin – Cooling Unit Rating Table Correction Factor Data in Miscellaneous Engineering Data section.

7.5 TON STANDARD EFFICIENCY KCB092S4M (1ST STAGE) - SINGLE ZONE VAV SUPPLY FAN SUPPLY AIR BLOWER

Entering Wet Bulb Temperature	Total Air Volume	Outdoor Air Temperature Entering Outdoor Coil																			
		65°F					75°F					85°F					95°F				
		Total Cool Cap.	Comp. Motor Input	Sensible To Total Ratio (S/T)			Total Cool Cap.	Comp. Motor Input	Sensible To Total Ratio (S/T)			Total Cool Cap.	Comp. Motor Input	Sensible To Total Ratio (S/T)			Total Cool Cap.	Comp. Motor Input	Sensible To Total Ratio (S/T)		
				Dry Bulb					Dry Bulb					Dry Bulb					Dry Bulb		
cfm	kBtuh	kW	75°F	80°F	85°F	kBtuh	kW	75°F	80°F	85°F	kBtuh	kW	75°F	80°F	85°F	kBtuh	kW	75°F	80°F	85°F	
63°F	1680	55.5	2.71	0.63	0.73	0.82	53.2	3.05	0.63	0.73	0.83	50.8	3.42	0.64	0.74	0.84	48.0	3.86	0.64	0.75	0.86
	2100	59.7	2.75	0.66	0.76	0.87	57.2	3.08	0.66	0.77	0.88	54.3	3.45	0.66	0.78	0.9	51.3	3.88	0.67	0.8	0.92
	2520	62.7	2.77	0.68	0.80	0.92	60.0	3.10	0.69	0.81	0.93	57.0	3.47	0.69	0.82	0.95	53.7	3.90	0.70	0.84	0.97
67°F	1680	58.2	2.73	0.51	0.61	0.70	55.8	3.06	0.51	0.61	0.70	53.2	3.44	0.52	0.61	0.71	50.4	3.88	0.52	0.62	0.72
	2100	62.5	2.77	0.53	0.63	0.73	59.9	3.09	0.54	0.64	0.74	57.1	3.47	0.54	0.64	0.75	53.9	3.90	0.54	0.65	0.76
	2520	65.9	2.79	0.55	0.65	0.77	63.0	3.12	0.55	0.66	0.78	59.9	3.49	0.55	0.67	0.79	56.5	3.93	0.56	0.68	0.81
71°F	1680	60.8	2.75	0.41	0.49	0.58	58.4	3.08	0.40	0.49	0.59	55.6	3.46	0.40	0.5	0.59	52.6	3.89	0.40	0.50	0.60
	2100	65.3	2.79	0.42	0.52	0.61	62.6	3.11	0.42	0.52	0.61	59.6	3.49	0.42	0.52	0.62	56.3	3.92	0.41	0.53	0.63
	2520	68.8	2.81	0.43	0.53	0.63	65.9	3.14	0.43	0.54	0.64	62.6	3.51	0.43	0.54	0.65	59.1	3.95	0.42	0.55	0.66

7.5 TON STANDARD EFFICIENCY KCB092S4M (2ND STAGE) - SINGLE ZONE VAV SUPPLY FAN SUPPLY AIR BLOWER

Entering Wet Bulb Temperature	Total Air Volume	Outdoor Air Temperature Entering Outdoor Coil																			
		85°F					95°F					105°F					115°F				
		Total Cool Cap.	Comp. Motor Input	Sensible To Total Ratio (S/T)			Total Cool Cap.	Comp. Motor Input	Sensible To Total Ratio (S/T)			Total Cool Cap.	Comp. Motor Input	Sensible To Total Ratio (S/T)			Total Cool Cap.	Comp. Motor Input	Sensible To Total Ratio (S/T)		
				Dry Bulb					Dry Bulb					Dry Bulb					Dry Bulb		
cfm	kBtuh	kW	75°F	80°F	85°F	kBtuh	kW	75°F	80°F	85°F	kBtuh	kW	75°F	80°F	85°F	kBtuh	kW	75°F	80°F	85°F	
63°F	2400	86.0	5.76	0.68	0.82	0.96	80.6	6.50	0.69	0.84	0.98	74.8	7.36	0.71	0.87	1.00	68.6	8.33	0.73	0.90	1.00
	3000	90.8	5.80	0.73	0.89	1.00	85.0	6.54	0.74	0.92	1.00	78.8	7.40	0.76	0.95	1.00	72.2	8.38	0.79	0.98	1.00
	3600	94.4	5.82	0.77	0.95	1.00	88.3	6.57	0.79	0.98	1.00	82.0	7.43	0.82	0.99	1.00	75.5	8.42	0.85	1.00	1.00
67°F	2400	90.7	5.79	0.54	0.66	0.78	85.2	6.54	0.54	0.67	0.80	79.3	7.40	0.55	0.69	0.83	72.7	8.38	0.56	0.70	0.86
	3000	96.0	5.83	0.57	0.70	0.85	89.9	6.58	0.57	0.72	0.88	83.5	7.45	0.58	0.74	0.91	76.7	8.43	0.59	0.77	0.95
	3600	99.7	5.85	0.59	0.75	0.92	93.4	6.61	0.60	0.77	0.95	86.6	7.48	0.61	0.79	0.98	79.3	8.47	0.63	0.83	1.00
71°F	2400	95.0	5.82	0.41	0.53	0.64	89.5	6.58	0.41	0.53	0.65	83.3	7.44	0.4	0.54	0.66	76.7	8.43	0.40	0.55	0.68
	3000	100.7	5.86	0.43	0.56	0.68	94.5	6.62	0.42	0.56	0.70	87.9	7.49	0.41	0.57	0.72	80.8	8.48	0.41	0.58	0.74
	3600	104.7	5.89	0.43	0.58	0.72	98.1	6.65	0.43	0.59	0.74	91.2	7.52	0.43	0.60	0.77	83.8	8.52	0.43	0.62	0.80

7.5 TON HIGH EFFICIENCY KCA092H4M (1ST STAGE) - SINGLE ZONE VAV SUPPLY FAN SUPPLY AIR BLOWER

Entering Wet Bulb Temperature	Total Air Volume	Outdoor Air Temperature Entering Outdoor Coil																			
		65°F					75°F					85°F					95°F				
		Total Cool Cap.	Comp. Motor Input	Sensible To Total Ratio (S/T)			Total Cool Cap.	Comp. Motor Input	Sensible To Total Ratio (S/T)			Total Cool Cap.	Comp. Motor Input	Sensible To Total Ratio (S/T)			Total Cool Cap.	Comp. Motor Input	Sensible To Total Ratio (S/T)		
				Dry Bulb					Dry Bulb					Dry Bulb					Dry Bulb		
cfm	kBtuh	kW	75°F	80°F	85°F	kBtuh	kW	75°F	80°F	85°F	kBtuh	kW	75°F	80°F	85°F	kBtuh	kW	75°F	80°F	85°F	
63°F	1680	43.6	1.94	0.59	0.69	0.81	41.9	2.20	0.59	0.70	0.82	40.0	2.49	0.59	0.71	0.84	38.0	2.81	0.59	0.72	0.86
	2100	46.8	1.95	0.61	0.74	0.88	44.8	2.21	0.61	0.76	0.90	42.8	2.49	0.63	0.77	0.92	40.6	2.82	0.63	0.79	0.95
	2520	49.1	1.96	0.65	0.80	0.96	47.0	2.21	0.66	0.81	0.98	44.8	2.50	0.67	0.83	1.00	42.5	2.82	0.68	0.86	1.00
67°F	1680	46.5	1.95	0.48	0.56	0.65	44.7	2.21	0.48	0.56	0.66	42.8	2.49	0.47	0.57	0.67	40.7	2.82	0.48	0.57	0.68
	2100	49.6	1.96	0.49	0.59	0.70	47.5	2.22	0.49	0.59	0.72	45.4	2.50	0.49	0.60	0.73	43.1	2.82	0.50	0.60	0.75
	2520	52.0	1.97	0.51	0.62	0.76	49.9	2.22	0.52	0.63	0.77	47.6	2.50	0.51	0.64	0.79	45.1	2.82	0.52	0.65	0.82
71°F	1680	49.4	1.96	0.38	0.46	0.54	47.5	2.22	0.38	0.46	0.54	45.5	2.50	0.38	0.46	0.55	43.4	2.82	0.37	0.46	0.55
	2100	52.6	1.97	0.38	0.48	0.57	50.6	2.22	0.38	0.48	0.57	48.4	2.51	0.38	0.48	0.57	46.0	2.83	0.38	0.48	0.58
	2520	54.9	1.98	0.39	0.49	0.59	52.6	2.23	0.39	0.50	0.60	50.3	2.51	0.39	0.50	0.61	47.8	2.83	0.39	0.50	0.63

7.5 TON HIGH EFFICIENCY KCA092H4M (2ND STAGE) - SINGLE ZONE VAV SUPPLY FAN SUPPLY AIR BLOWER

Entering Wet Bulb Temperature	Total Air Volume	Outdoor Air Temperature Entering Outdoor Coil																			
		85°F					95°F					105°F					115°F				
		Total Cool Cap.	Comp. Motor Input	Sensible To Total Ratio (S/T)			Total Cool Cap.	Comp. Motor Input	Sensible To Total Ratio (S/T)			Total Cool Cap.	Comp. Motor Input	Sensible To Total Ratio (S/T)			Total Cool Cap.	Comp. Motor Input	Sensible To Total Ratio (S/T)		
				Dry Bulb					Dry Bulb					Dry Bulb					Dry Bulb		
cfm	kBtuh	kW	75°F	80°F	85°F	kBtuh	kW	75°F	80°F	85°F	kBtuh	kW	75°F	80°F	85°F	kBtuh	kW	75°F	80°F	85°F	
63°F	2400	87.9	4.98	0.68	0.83	0.99	83.4	5.62	0.69	0.85	1.00	78.4	6.36	0.71	0.88	1.00	73.1	7.23	0.73	0.92	1.00
	3000	92.4	4.99	0.74	0.92	1.00	87.6	5.63	0.76	0.96	1.00	82.3	6.37	0.78	0.98	1.00	76.8	7.22	0.80	1.00	1.00
	3600	96.0	5.00	0.80	1.00	1.00	91.2	5.64	0.82	1.00	1.00	86.4	6.37	0.85	1.00	1.00	81.2	7.22	0.88	1.00	1.00
67°F	2400	93.3	4.99	0.54	0.66	0.79	88.4	5.63	0.54	0.67	0.81	83.3	6.37	0.55	0.68	0.84	78.0	7.23	0.56	0.71	0.88
	3000	97.9	5.00	0.57	0.71	0.88	93.0	5.64	0.58	0.73	0.91	87.2	6.37	0.59	0.75	0.95	81.1	7.22	0.59	0.78	0.99
	3600	101.4	5.01	0.61	0.77	0.97	95.6	5.64	0.61	0.79	1.00	90.0	6.38	0.62	0.82	1.00	83.6	7.22	0.64	0.86	1.00
71°F	2400	99.1	5.00	0.41	0.52	0.64	94.0	5.64	0.41	0.53	0.65	88.6	6.37	0.40	0.54	0.66	82.7	7.22	0.41	0.55	0.68
	3000	103.3	5.01	0.42	0.56	0.69	98.0	5.65	0.42	0.57	0.71	92.2	6.38	0.42	0.58	0.73	86.0	7.23	0.43	0.59	0.75
	3600	106.9	5.02	0.44	0.60	0.75	101.2	5.66	0.43	0.60	0.77	95.0	6.38	0.44	0.61	0.80	88.3	7.22	0.44	0.63	0.84

RATINGS

NOTE – For Temperatures and Capacities not shown in tables, see bulletin – Cooling Unit Rating Table Correction Factor Data in Miscellaneous Engineering Data section.

8.5 TON STANDARD EFFICIENCY KCB102S4M (1ST STAGE) - SINGLE ZONE VAV SUPPLY FAN SUPPLY AIR BLOWER

Entering Wet Bulb Temperature	Total Air Volume	Outdoor Air Temperature Entering Outdoor Coil																			
		65°F					75°F					85°F					95°F				
		Total Cool Cap.	Comp. Motor Input	Sensible To Total Ratio (S/T)			Total Cool Cap.	Comp. Motor Input	Sensible To Total Ratio (S/T)			Total Cool Cap.	Comp. Motor Input	Sensible To Total Ratio (S/T)			Total Cool Cap.	Comp. Motor Input	Sensible To Total Ratio (S/T)		
				Dry Bulb					Dry Bulb					Dry Bulb					Dry Bulb		
cfm	kBtuh	kW	75°F	80°F	85°F	kBtuh	kW	75°F	80°F	85°F	kBtuh	kW	75°F	80°F	85°F	kBtuh	kW	75°F	80°F	85°F	
63°F	1920	51.1	2.42	0.62	0.73	0.83	48.0	2.69	0.62	0.73	0.84	44.6	3.00	0.61	0.73	0.85	41.1	3.37	0.61	0.74	0.87
	2400	55.7	2.42	0.65	0.77	0.89	52.2	2.70	0.65	0.78	0.90	48.7	3.01	0.65	0.79	0.92	44.8	3.38	0.65	0.80	0.95
	2880	59.1	2.43	0.68	0.81	0.95	55.5	2.70	0.68	0.82	0.96	51.6	3.01	0.69	0.84	0.98	47.5	3.38	0.69	0.86	1.00
67°F	1920	54.4	2.42	0.51	0.60	0.70	51.2	2.69	0.49	0.60	0.70	47.8	3.01	0.48	0.59	0.70	44.1	3.38	0.47	0.59	0.70
	2400	59.1	2.43	0.52	0.63	0.74	55.6	2.70	0.52	0.63	0.75	51.9	3.01	0.51	0.63	0.75	48.0	3.39	0.50	0.63	0.76
	2880	62.7	2.43	0.54	0.66	0.78	59.0	2.71	0.54	0.66	0.79	55.1	3.02	0.53	0.67	0.80	50.8	3.39	0.53	0.67	0.82
71°F	1920	57.6	2.42	0.40	0.49	0.58	54.2	2.69	0.38	0.48	0.58	50.8	3.01	0.37	0.47	0.57	47.0	3.38	0.35	0.46	0.57
	2400	62.4	2.43	0.41	0.51	0.61	58.9	2.71	0.40	0.51	0.61	55.1	3.02	0.38	0.5	0.61	51.0	3.40	0.37	0.49	0.61
	2880	66.1	2.44	0.42	0.53	0.64	62.3	2.72	0.41	0.53	0.64	58.3	3.03	0.40	0.52	0.65	54.0	3.41	0.38	0.52	0.65

8.5 TON STANDARD EFFICIENCY KCB102S4M (2ND STAGE) - SINGLE ZONE VAV SUPPLY FAN SUPPLY AIR BLOWER

Entering Wet Bulb Temperature	Total Air Volume	Outdoor Air Temperature Entering Outdoor Coil																			
		85°F					95°F					105°F					115°F				
		Total Cool Cap.	Comp. Motor Input	Sensible To Total Ratio (S/T)			Total Cool Cap.	Comp. Motor Input	Sensible To Total Ratio (S/T)			Total Cool Cap.	Comp. Motor Input	Sensible To Total Ratio (S/T)			Total Cool Cap.	Comp. Motor Input	Sensible To Total Ratio (S/T)		
				Dry Bulb					Dry Bulb					Dry Bulb					Dry Bulb		
cfm	kBtuh	kW	75°F	80°F	85°F	kBtuh	kW	75°F	80°F	85°F	kBtuh	kW	75°F	80°F	85°F	kBtuh	kW	75°F	80°F	85°F	
63°F	2720	95.0	6.52	0.67	0.82	0.96	87.4	7.34	0.67	0.83	0.99	79.3	8.28	0.68	0.85	1.00	70.8	9.42	0.69	0.88	1.00
	3400	101.3	6.54	0.72	0.89	1.00	93.1	7.35	0.73	0.91	1.00	84.6	8.30	0.74	0.94	1.00	75.4	9.43	0.76	0.98	1.00
	4080	105.8	6.55	0.77	0.96	1.00	97.1	7.37	0.78	0.98	1.00	88.4	8.31	0.80	1.00	1.00	79.8	9.44	0.83	1.00	1.00
67°F	2720	101.4	6.54	0.52	0.65	0.78	93.5	7.34	0.52	0.66	0.80	85.3	8.30	0.50	0.66	0.82	76.5	9.43	0.50	0.67	0.84
	3400	108.0	6.56	0.55	0.70	0.85	99.6	7.37	0.55	0.71	0.87	90.8	8.31	0.55	0.72	0.90	81.5	9.43	0.54	0.74	0.94
	4080	112.7	6.57	0.58	0.75	0.92	103.9	7.37	0.58	0.76	0.95	94.8	8.33	0.58	0.78	0.98	85.1	9.46	0.59	0.81	1.00
71°F	2720	107.3	6.56	0.38	0.52	0.63	99.5	7.37	0.37	0.51	0.64	91.0	8.31	0.35	0.50	0.64	82.1	9.45	0.33	0.49	0.65
	3400	114.3	6.58	0.40	0.54	0.68	105.7	7.39	0.39	0.54	0.69	96.6	8.34	0.37	0.54	0.70	87.2	9.46	0.35	0.54	0.72
	4080	119.3	6.60	0.41	0.58	0.73	110.2	7.40	0.4	0.58	0.74	100.80	8.36	0.39	0.58	0.76	90.9	9.49	0.38	0.59	0.78

8.5 TON HIGH EFFICIENCY KCA102H4M (1ST STAGE) - SINGLE ZONE VAV SUPPLY FAN SUPPLY AIR BLOWER

Entering Wet Bulb Temperature	Total Air Volume	Outdoor Air Temperature Entering Outdoor Coil																			
		65°F					75°F					85°F					95°F				
		Total Cool Cap.	Comp. Motor Input	Sensible To Total Ratio (S/T)			Total Cool Cap.	Comp. Motor Input	Sensible To Total Ratio (S/T)			Total Cool Cap.	Comp. Motor Input	Sensible To Total Ratio (S/T)			Total Cool Cap.	Comp. Motor Input	Sensible To Total Ratio (S/T)		
				Dry Bulb					Dry Bulb					Dry Bulb					Dry Bulb		
cfm	kBtuh	kW	75°F	80°F	85°F	kBtuh	kW	75°F	80°F	85°F	kBtuh	kW	75°F	80°F	85°F	kBtuh	kW	75°F	80°F	85°F	
63°F	1920	49.6	2.15	0.56	0.68	0.81	47.0	2.44	0.56	0.69	0.83	44.4	2.76	0.56	0.70	0.84	41.5	3.12	0.56	0.71	0.87
	2400	53.3	2.16	0.59	0.74	0.90	50.5	2.45	0.60	0.76	0.93	47.5	2.76	0.60	0.77	0.95	44.3	3.13	0.61	0.79	0.98
	2880	55.8	2.17	0.63	0.81	0.99	53.0	2.45	0.64	0.83	1.00	49.8	2.77	0.66	0.85	1.00	46.5	3.13	0.67	0.88	1.00
67°F	1920	53.0	2.16	0.46	0.54	0.64	50.5	2.45	0.45	0.54	0.65	47.7	2.76	0.45	0.54	0.65	44.7	3.13	0.44	0.54	0.66
	2400	56.7	2.17	0.47	0.57	0.70	53.9	2.46	0.47	0.57	0.72	50.8	2.77	0.46	0.58	0.73	47.6	3.13	0.46	0.58	0.75
	2880	59.4	2.18	0.49	0.61	0.77	56.4	2.46	0.49	0.62	0.78	53.2	2.78	0.49	0.63	0.80	49.8	3.14	0.50	0.64	0.84
71°F	1920	56.6	2.17	0.36	0.44	0.52	54.0	2.46	0.35	0.44	0.52	51.0	2.77	0.34	0.44	0.52	48.0	3.13	0.33	0.43	0.53
	2400	60.3	2.18	0.37	0.46	0.55	57.3	2.46	0.36	0.46	0.55	54.2	2.78	0.35	0.46	0.56	50.9	3.14	0.34	0.46	0.56
	2880	63.0	2.19	0.38	0.48	0.58	59.7	2.47	0.37	0.48	0.59	56.5	2.79	0.36	0.48	0.60	53.0	3.14	0.36	0.48	0.62

8.5 TON HIGH EFFICIENCY KCA102H4M (2ND STAGE) - SINGLE ZONE VAV SUPPLY FAN SUPPLY AIR BLOWER

Entering Wet Bulb Temperature	Total Air Volume	Outdoor Air Temperature Entering Outdoor Coil																			
		85°F					95°F					105°F					115°F				
		Total Cool Cap.	Comp. Motor Input	Sensible To Total Ratio (S/T)			Total Cool Cap.	Comp. Motor Input	Sensible To Total Ratio (S/T)			Total Cool Cap.	Comp. Motor Input	Sensible To Total Ratio (S/T)			Total Cool Cap.	Comp. Motor Input	Sensible To Total Ratio (S/T)		
				Dry Bulb					Dry Bulb					Dry Bulb					Dry Bulb		
cfm	kBtuh	kW	75°F	80°F	85°F	kBtuh	kW	75°F	80°F	85°F	kBtuh	kW	75°F	80°F	85°F	kBtuh	kW	75°F	80°F	85°F	
63°F	2720	98.9	5.54	0.70	0.85	1.00	92.5	6.27	0.71	0.87	1.00	85.7	7.10	0.71	0.90	1.00	78.6	8.09	0.73	0.94	1.00
	3400	104.2	5.56	0.76	0.95	1.00	97.5	6.27	0.77	0.98	1.00	90.4	7.11	0.79	1.00	1.00	83.6	8.08	0.82	1.00	1.00
	4080	108.6	5.56	0.82	1.00	1.00	102.3	6.28	0.84	1.00	1.00	95.9	7.12	0.87	1.00	1.00	88.9	8.08	0.91	1.00	1.00
67°F	2720	105.6	5.56	0.53	0.67	0.81	98.9	6.28	0.53	0.68	0.83	91.8	7.11	0.54	0.69	0.87	84.4	8.08	0.55	0.71	0.90
	3400	110.9	5.57	0.58	0.74	0.91	103.8	6.29	0.59	0.75	0.94	96.4	7.12	0.59	0.77	0.97	88.5	8.08	0.59	0.79	1.00
	4080	114.8	5.58	0.61	0.80	0.99	107.2	6.30	0.62	0.82	1.00	99.6	7.12	0.63	0.85	1.00	91.5	8.08	0.63	0.88	1.00
71°F	2720	112.1	5.57	0.40	0.53	0.65	105.2	6.29	0.39	0.53	0.66	98.1	7.12	0.38	0.53	0.67	90.3	8.08	0.38	0.54	0.69
	3400	117.6	5.59	0.42	0.57	0.72	110.4	6.30	0.41	0.58	0.73	102.7	7.12	0.41	0.58	0.75	94.3	8.08	0.40	0.59	0.77
	4080	121.7	5.60	0.44	0.61	0.77	113.9	6.31	0.43	0.61	0.79	105.9	7.13	0.42	0.62	0.83	97.4	8.08	0.43	0.63	0.86

RATINGS

NOTE – For Temperatures and Capacities not shown in tables, see bulletin – Cooling Unit Rating Table Correction Factor Data in Miscellaneous Engineering Data section.

10 TON STANDARD EFFICIENCY KCB120S4M (1ST STAGE) - SINGLE ZONE VAV SUPPLY FAN SUPPLY AIR BLOWER

Entering Wet Bulb Temperature	Total Air Volume	Outdoor Air Temperature Entering Outdoor Coil																			
		65°F					75°F					85°F					95°F				
		Total Cool Cap.	Comp. Motor Input	Sensible To Total Ratio (S/T)			Total Cool Cap.	Comp. Motor Input	Sensible To Total Ratio (S/T)			Total Cool Cap.	Comp. Motor Input	Sensible To Total Ratio (S/T)			Total Cool Cap.	Comp. Motor Input	Sensible To Total Ratio (S/T)		
				Dry Bulb					Dry Bulb					Dry Bulb					Dry Bulb		
cfm	kBtuh	kW	75°F	80°F	85°F	kBtuh	kW	75°F	80°F	85°F	kBtuh	kW	75°F	80°F	85°F	kBtuh	kW	75°F	80°F	85°F	
63°F	2240	56.7	2.72	0.62	0.73	0.84	53.0	3.05	0.62	0.73	0.85	49.0	3.43	0.61	0.73	0.86	44.7	3.87	0.60	0.74	0.88
	2800	61.6	2.73	0.66	0.78	0.90	57.5	3.06	0.66	0.79	0.92	53.2	3.45	0.65	0.80	0.93	48.5	3.90	0.65	0.81	0.96
	3360	65.1	2.74	0.69	0.83	0.96	60.8	3.08	0.70	0.84	0.98	56.2	3.47	0.70	0.85	1.00	51.5	3.92	0.70	0.87	1.00
67°F	2240	61.1	2.73	0.50	0.60	0.70	57.2	3.06	0.49	0.60	0.70	53.1	3.45	0.48	0.59	0.70	48.7	3.90	0.46	0.58	0.71
	2800	66.1	2.74	0.53	0.64	0.75	61.9	3.09	0.51	0.64	0.75	57.5	3.48	0.51	0.63	0.76	52.7	3.93	0.49	0.63	0.77
71°F	2240	65.5	2.73	0.40	0.49	0.58	61.4	3.08	0.38	0.48	0.58	57.2	3.48	0.36	0.47	0.57	52.7	3.93	0.34	0.45	0.56
	2800	70.6	2.76	0.41	0.51	0.62	66.3	3.10	0.39	0.51	0.61	61.7	3.50	0.38	0.50	0.61	56.8	3.96	0.35	0.49	0.61
	3360	74.5	2.76	0.42	0.54	0.65	69.8	3.12	0.40	0.53	0.65	65.0	3.52	0.39	0.52	0.66	59.9	3.98	0.37	0.52	0.66

10 TON STANDARD EFFICIENCY KCB120S4M (2ND STAGE) - SINGLE ZONE VAV SUPPLY FAN SUPPLY AIR BLOWER

Entering Wet Bulb Temperature	Total Air Volume	Outdoor Air Temperature Entering Outdoor Coil																			
		85°F					95°F					105°F					115°F				
		Total Cool Cap.	Comp. Motor Input	Sensible To Total Ratio (S/T)			Total Cool Cap.	Comp. Motor Input	Sensible To Total Ratio (S/T)			Total Cool Cap.	Comp. Motor Input	Sensible To Total Ratio (S/T)			Total Cool Cap.	Comp. Motor Input	Sensible To Total Ratio (S/T)		
				Dry Bulb					Dry Bulb					Dry Bulb					Dry Bulb		
cfm	kBtuh	kW	75°F	80°F	85°F	kBtuh	kW	75°F	80°F	85°F	kBtuh	kW	75°F	80°F	85°F	kBtuh	kW	75°F	80°F	85°F	
63°F	3200	114.0	7.38	0.68	0.83	0.98	104.2	8.32	0.68	0.85	1.00	93.9	9.38	0.68	0.87	1.00	83.2	10.57	0.69	0.91	1.00
	4000	121.0	7.42	0.73	0.92	1.00	111.1	8.38	0.74	0.94	1.00	100.5	9.44	0.76	0.97	1.00	89.4	10.64	0.78	1.00	1.00
	4800	126.9	7.46	0.79	0.99	1.00	116.4	8.42	0.81	1.00	1.00	106.5	9.50	0.83	1.00	1.00	96.0	10.71	0.86	1.00	1.00
67°F	3200	123.1	7.43	0.52	0.66	0.79	113.0	8.39	0.51	0.66	0.81	102.5	9.46	0.50	0.67	0.83	91.5	10.66	0.49	0.67	0.87
	4000	130.6	7.48	0.55	0.71	0.88	120.0	8.44	0.55	0.72	0.90	108.8	9.52	0.55	0.74	0.93	97.0	10.73	0.55	0.76	0.98
71°F	4800	136.0	7.51	0.59	0.77	0.95	124.9	8.48	0.59	0.78	0.98	113.3	9.56	0.59	0.81	1.00	101.2	10.77	0.60	0.84	1.00
	3200	131.9	7.49	0.38	0.51	0.64	121.7	8.45	0.36	0.50	0.64	110.7	9.53	0.34	0.50	0.65	99.4	10.75	0.32	0.49	0.65
	4000	139.7	7.54	0.40	0.55	0.69	128.7	8.50	0.39	0.55	0.70	117.5	9.60	0.37	0.55	0.72	105.4	10.82	0.35	0.55	0.74
4800	145.4	7.58	0.42	0.58	0.75	134.0	8.56	0.41	0.59	0.76	122.3	9.65	0.39	0.59	0.78	109.7	10.88	0.38	0.60	0.82	

10 TON HIGH EFFICIENCY KCA120H4M (1ST STAGE) - SINGLE ZONE VAV SUPPLY FAN SUPPLY AIR BLOWER

Entering Wet Bulb Temperature	Total Air Volume	Outdoor Air Temperature Entering Outdoor Coil																			
		65°F					75°F					85°F					95°F				
		Total Cool Cap.	Comp. Motor Input	Sensible To Total Ratio (S/T)			Total Cool Cap.	Comp. Motor Input	Sensible To Total Ratio (S/T)			Total Cool Cap.	Comp. Motor Input	Sensible To Total Ratio (S/T)			Total Cool Cap.	Comp. Motor Input	Sensible To Total Ratio (S/T)		
				Dry Bulb					Dry Bulb					Dry Bulb					Dry Bulb		
cfm	kBtuh	kW	75°F	80°F	85°F	kBtuh	kW	75°F	80°F	85°F	kBtuh	kW	75°F	80°F	85°F	kBtuh	kW	75°F	80°F	85°F	
63°F	2240	60.2	2.71	0.60	0.71	0.82	57.7	3.09	0.60	0.72	0.84	54.8	3.50	0.60	0.72	0.85	51.7	3.97	0.61	0.73	0.87
	2800	64.6	2.75	0.63	0.76	0.90	61.6	3.12	0.63	0.77	0.92	58.6	3.53	0.64	0.79	0.94	55.3	3.99	0.65	0.80	0.96
	3360	67.8	2.77	0.66	0.82	0.97	64.6	3.14	0.67	0.83	0.99	61.2	3.55	0.68	0.85	1.00	57.8	4.02	0.69	0.87	1.00
67°F	2240	64.4	2.74	0.49	0.58	0.67	61.6	3.12	0.49	0.58	0.68	58.7	3.53	0.48	0.58	0.69	55.5	4.00	0.48	0.58	0.70
	2800	68.7	2.78	0.51	0.61	0.73	65.6	3.15	0.51	0.61	0.73	62.2	3.56	0.50	0.61	0.75	58.8	4.03	0.50	0.62	0.77
71°F	3360	71.9	2.81	0.52	0.64	0.78	68.6	3.18	0.52	0.65	0.80	65.1	3.59	0.52	0.66	0.81	61.5	4.06	0.52	0.67	0.83
	2240	68.6	2.78	0.39	0.47	0.55	65.7	3.15	0.38	0.47	0.55	62.6	3.57	0.38	0.47	0.56	59.2	4.03	0.37	0.47	0.56
	2800	72.9	2.82	0.39	0.49	0.59	69.7	3.19	0.39	0.49	0.59	66.4	3.60	0.38	0.49	0.59	62.8	4.07	0.38	0.49	0.60
3360	76.0	2.85	0.40	0.51	0.62	72.6	3.22	0.39	0.51	0.62	69.3	3.64	0.39	0.53	0.63	65.2	4.10	0.39	0.51	0.64	

10 TON HIGH EFFICIENCY KCA120H4M (2ND STAGE) - SINGLE ZONE VAV SUPPLY FAN SUPPLY AIR BLOWER

Entering Wet Bulb Temperature	Total Air Volume	Outdoor Air Temperature Entering Outdoor Coil																			
		85°F					95°F					105°F					115°F				
		Total Cool Cap.	Comp. Motor Input	Sensible To Total Ratio (S/T)			Total Cool Cap.	Comp. Motor Input	Sensible To Total Ratio (S/T)			Total Cool Cap.	Comp. Motor Input	Sensible To Total Ratio (S/T)			Total Cool Cap.	Comp. Motor Input	Sensible To Total Ratio (S/T)		
				Dry Bulb					Dry Bulb					Dry Bulb					Dry Bulb		
cfm	kBtuh	kW	75°F	80°F	85°F	kBtuh	kW	75°F	80°F	85°F	kBtuh	kW	75°F	80°F	85°F	kBtuh	kW	75°F	80°F	85°F	
63°F	3200	118.9	7.05	0.68	0.84	1.00	112.1	7.96	0.69	0.86	1.00	104.6	9.00	0.71	0.89	1.00	96.6	10.17	0.72	0.93	1.00
	4000	124.9	7.11	0.74	0.94	1.00	117.7	8.03	0.76	0.97	1.00	110.0	9.05	0.78	1.00	1.00	102.2	10.23	0.80	1.00	1.00
	4800	129.9	7.17	0.80	1.00	1.00	123.0	8.08	0.83	1.00	1.00	115.7	9.12	0.86	1.00	1.00	108.0	10.30	0.90	1.00	1.00
67°F	3200	126.5	7.12	0.53	0.66	0.80	119.2	8.03	0.53	0.67	0.82	111.4	9.07	0.53	0.68	0.85	103.4	10.25	0.54	0.70	0.89
	4000	132.6	7.19	0.57	0.72	0.90	124.8	8.10	0.57	0.73	0.93	116.7	9.13	0.58	0.75	0.97	108.0	10.30	0.59	0.78	1.00
71°F	4800	137.1	7.25	0.60	0.78	0.99	128.9	8.15	0.61	0.80	1.00	120.2	9.18	0.61	0.83	1.00	111.3	10.34	0.63	0.87	1.00
	3200	134.2	7.21	0.40	0.53	0.64	126.6	8.12	0.39	0.52	0.65	118.5	9.15	0.39	0.52	0.66	110.0	10.32	0.39	0.54	0.68
	4000	140.0	7.28	0.41	0.56	0.70	132.0	8.19	0.41	0.57	0.71	123.5	9.22	0.41	0.57	0.73	114.7	10.38	0.41	0.58	0.76
4800	144.5	7.34	0.43	0.60	0.76	136.2	8.24	0.43	0.61	0.78	127.2	9.27	0.43	0.61	0.81	117.9	10.43	0.42	0.63	0.84	

RATINGS

NOTE – For Temperatures and Capacities not shown in tables, see bulletin – Cooling Unit Rating Table Correction Factor Data in Miscellaneous Engineering Data section.

12.5 TON STANDARD EFFICIENCY KCB150S4M (1ST STAGE) - SINGLE ZONE VAV SUPPLY FAN SUPPLY AIR BLOWER

Entering Wet Bulb Temperature	Total Air Volume	Outdoor Air Temperature Entering Outdoor Coil																			
		65°F					75°F					85°F					95°F				
		Total Cool Cap.	Comp. Motor Input	Sensible To Total Ratio (S/T) Dry Bulb			Total Cool Cap.	Comp. Motor Input	Sensible To Total Ratio (S/T) Dry Bulb			Total Cool Cap.	Comp. Motor Input	Sensible To Total Ratio (S/T) Dry Bulb			Total Cool Cap.	Comp. Motor Input	Sensible To Total Ratio (S/T) Dry Bulb		
				75°F	80°F	85°F			75°F	80°F	85°F			75°F	80°F	85°F			75°F	80°F	85°F
		cfm	kBtuh	kW	75°F	80°F	85°F	kBtuh	kW	75°F	80°F	85°F	kBtuh	kW	75°F	80°F	85°F	kBtuh	kW	75°F	80°F
63°F	2560	68.8	3.41	0.64	0.74	0.84	64.5	3.8	0.63	0.74	0.85	60	4.21	0.62	0.74	0.86	55.3	4.66	0.62	0.75	0.88
	3200	74.6	3.44	0.67	0.79	0.91	70.1	3.82	0.67	0.8	0.92	65.2	4.22	0.67	0.8	0.94	60.3	4.68	0.67	0.82	0.96
	3480	76.6	3.45	0.69	0.81	0.93	72	3.82	0.69	0.82	0.95	67.2	4.23	0.69	0.83	0.97	61.9	4.68	0.69	0.84	0.99
67°F	2560	74.2	3.44	0.51	0.62	0.71	69.9	3.82	0.5	0.61	0.71	65.4	4.23	0.49	0.6	0.71	60.6	4.69	0.48	0.6	0.72
	3200	80	3.46	0.54	0.65	0.76	75.3	3.84	0.53	0.64	0.76	70.6	4.25	0.52	0.65	0.77	65.3	4.7	0.51	0.65	0.78
	3480	82.1	3.47	0.55	0.67	0.78	77.5	3.84	0.54	0.66	0.78	72.5	4.25	0.53	0.66	0.8	67.1	4.7	0.52	0.67	0.81
71°F	2560	79.9	3.46	0.41	0.5	0.59	75.6	3.84	0.39	0.49	0.58	70.8	4.24	0.37	0.48	0.58	65.9	4.7	0.35	0.47	0.58
	3200	86	3.49	0.42	0.52	0.63	81.4	3.86	0.4	0.52	0.62	76.5	4.27	0.39	0.51	0.63	71.1	4.72	0.37	0.5	0.62
	3480	88.2	3.5	0.42	0.53	0.64	83.4	3.87	0.41	0.53	0.64	78.3	4.27	0.4	0.52	0.64	72.9	4.73	0.38	0.52	0.64

12.5 TON STANDARD EFFICIENCY KCB150S4M (2ND STAGE) - SINGLE ZONE VAV SUPPLY FAN SUPPLY AIR BLOWER

Entering Wet Bulb Temperature	Total Air Volume	Outdoor Air Temperature Entering Outdoor Coil																			
		85°F					95°F					105°F					115°F				
		Total Cool Cap.	Comp. Motor Input	Sensible To Total Ratio (S/T) Dry Bulb			Total Cool Cap.	Comp. Motor Input	Sensible To Total Ratio (S/T) Dry Bulb			Total Cool Cap.	Comp. Motor Input	Sensible To Total Ratio (S/T) Dry Bulb			Total Cool Cap.	Comp. Motor Input	Sensible To Total Ratio (S/T) Dry Bulb		
				75°F	80°F	85°F			75°F	80°F	85°F			75°F	80°F	85°F			75°F	80°F	85°F
		cfm	kBtuh	kW	75°F	80°F	85°F	kBtuh	kW	75°F	80°F	85°F	kBtuh	kW	75°F	80°F	85°F	kBtuh	kW	75°F	80°F
63°F	3800	146.9	9.2	0.69	0.84	0.98	135.7	10.21	0.7	0.86	1	124.2	11.34	0.7	0.88	1	111.9	12.62	0.72	0.91	1
	4400	153	9.23	0.73	0.89	1	141.3	10.23	0.74	0.91	1	129.5	11.37	0.75	0.94	1	117	12.65	0.77	0.98	1
	5000	158	9.26	0.76	0.94	1	146.2	10.27	0.77	0.97	1	134.2	11.4	0.8	0.99	1	121.8	12.67	0.82	1	1
67°F	3800	157.9	9.26	0.54	0.67	0.81	146.4	10.26	0.53	0.68	0.82	134.6	11.39	0.52	0.68	0.84	122.2	12.68	0.51	0.69	0.87
	4400	164.1	9.29	0.56	0.71	0.86	152.4	10.3	0.56	0.72	0.88	139.9	11.43	0.55	0.73	0.9	127.1	12.7	0.55	0.75	0.94
	5000	169.2	9.32	0.58	0.74	0.91	157.1	10.33	0.58	0.75	0.93	144.6	11.47	0.58	0.77	0.96	131.1	12.73	0.59	0.79	0.99
71°F	3800	169.9	9.32	0.39	0.53	0.65	158	10.34	0.38	0.52	0.65	145.8	11.47	0.37	0.52	0.66	132.7	12.74	0.35	0.51	0.67
	4400	176	9.36	0.41	0.55	0.69	163.6	10.36	0.4	0.55	0.7	151.1	11.51	0.38	0.54	0.71	137.4	12.77	0.37	0.54	0.72
	5000	180.9	9.39	0.42	0.57	0.72	168.2	10.39	0.41	0.57	0.73	155.3	11.52	0.4	0.57	0.75	141.4	12.79	0.39	0.58	0.77

DEHUMIDIFICATION SYSTEM RATINGS

NOTE - For Temperatures and Capacities not shown in tables, see bulletin - Cooling Unit Rating Table Correction Factor Data in Miscellaneous Engineering Data section.

7.5 TON STANDARD EFFICIENCY WITH KCB092S4 DEHUMIDIFICATION OPERATING (1ST STAGE)

Entering Wet Bulb Temperature	Total Air Volume	Outdoor Air Temperature Entering Outdoor Coil																				
		65°F						75°F					85°F					95°F				
		Total Cool Cap.	Comp. Motor Input	Sensible To Total Ratio (S/T)			Total Cool Cap.	Comp. Motor Input	Sensible To Total Ratio (S/T)			Total Cool Cap.	Comp. Motor Input	Sensible To Total Ratio (S/T)			Total Cool Cap.	Comp. Motor Input	Sensible To Total Ratio (S/T)			
				Dry Bulb					Dry Bulb					Dry Bulb					Dry Bulb			
cfm	kBtuh	kW	75°F	80°F	85°F	kBtuh	kW	75°F	80°F	85°F	kBtuh	kW	75°F	80°F	85°F	kBtuh	kW	75°F	80°F	85°F		
63°F	2400	38.7	3.9	0.48	0.63	0.78	30.9	3.8	0.34	0.57	0.79	23.1	3.8	0.20	0.50	0.80	15.3	3.7	0.06	0.43	0.80	
	3000	40.8	3.3	0.53	0.71	0.88	31.7	3.4	0.37	0.68	0.89	22.7	3.6	0.22	0.64	0.90	13.6	3.8	0.06	0.61	0.90	
	3600	42.9	2.6	0.58	0.78	0.98	32.6	3.0	0.40	0.78	0.98	22.3	3.3	0.23	0.79	0.99	12.0	3.6	0.05	0.79	1.00	
67°F	2400	44.3	3.3	0.34	0.48	0.62	36.3	3.1	0.20	0.39	0.58	28.3	2.9	0.05	0.30	0.55	20.3	2.7	-0.10	0.21	0.51	
	3000	46.5	3.0	0.37	0.60	0.69	37.3	2.9	0.20	0.50	0.65	28.0	2.8	0.02	0.39	0.62	18.8	2.7	-0.15	0.29	0.59	
	3600	48.7	2.7	0.40	0.73	0.75	38.2	3.0	0.20	0.61	0.73	27.8	3.3	0.00	0.49	0.70	17.3	3.6	-0.20	0.37	0.67	
71°F	2400	50.0	2.7	0.20	0.33	0.45	41.8	3.1	0.05	0.21	0.38	33.6	3.4	-0.11	0.10	0.30	25.4	3.8	-0.27	-0.02	0.23	
	3000	52.2	2.7	0.21	0.50	0.49	42.8	3.0	0.02	0.32	0.42	33.4	3.3	-0.17	0.14	0.35	24.0	3.6	-0.36	-0.04	0.28	
	3600	54.5	2.7	0.22	0.68	0.53	43.9	3.0	0.00	0.43	0.47	33.2	3.4	-0.23	0.19	0.40	22.6	3.7	-0.45	-0.06	0.34	

7.5 TON STANDARD EFFICIENCY WITH KCB092S4 DEHUMIDIFICATION OPERATING (2ND STAGE)

Entering Wet Bulb Temperature	Total Air Volume	Outdoor Air Temperature Entering Outdoor Coil																				
		65°F						75°F					85°F					95°F				
		Total Cool Cap.	Comp. Motor Input	Sensible To Total Ratio (S/T)			Total Cool Cap.	Comp. Motor Input	Sensible To Total Ratio (S/T)			Total Cool Cap.	Comp. Motor Input	Sensible To Total Ratio (S/T)			Total Cool Cap.	Comp. Motor Input	Sensible To Total Ratio (S/T)			
				Dry Bulb					Dry Bulb					Dry Bulb					Dry Bulb			
cfm	kBtuh	kW	75°F	80°F	85°F	kBtuh	kW	75°F	80°F	85°F	kBtuh	kW	75°F	80°F	85°F	kBtuh	kW	75°F	80°F	85°F		
63°F	2400	73.2	4.4	0.60	0.73	0.87	62.6	5.1	0.58	0.76	0.92	52.0	5.7	0.56	0.78	0.96	41.3	6.3	0.54	0.80	1.00	
	3000	77.7	4.5	0.64	0.79	0.94	66.4	5.0	0.63	0.80	0.93	55.2	5.6	0.63	0.81	0.92	43.9	6.2	0.62	0.82	0.92	
	3600	82.1	4.5	0.68	0.84	1.00	70.3	5.0	0.69	0.84	0.94	58.4	5.6	0.69	0.84	0.89	46.6	6.1	0.70	0.84	0.83	
67°F	2400	80.6	4.5	0.43	0.57	0.71	70.5	5.1	0.40	0.55	0.72	60.4	5.7	0.37	0.52	0.73	50.3	6.3	0.34	0.50	0.75	
	3000	85.8	4.5	0.46	0.61	0.76	74.5	5.1	0.44	0.63	0.76	63.1	5.7	0.41	0.65	0.75	51.8	6.3	0.39	0.67	0.74	
	3600	91.0	4.5	0.49	0.65	0.82	78.4	5.1	0.47	0.71	0.79	65.8	5.6	0.45	0.77	0.77	53.2	6.2	0.43	0.83	0.74	
71°F	2400	88.0	4.7	0.27	0.41	0.54	78.4	5.2	0.23	0.34	0.53	68.8	5.8	0.19	0.27	0.51	59.2	6.4	0.15	0.20	0.49	
	3000	93.9	4.6	0.29	0.44	0.59	82.5	5.2	0.24	0.47	0.59	71.0	5.7	0.20	0.49	0.58	59.6	6.3	0.15	0.52	0.57	
	3600	99.9	4.5	0.30	0.47	0.64	86.5	5.1	0.25	0.59	0.64	73.2	5.7	0.20	0.71	0.65	59.9	6.3	0.15	0.83	0.65	

8.5 TON STANDARD EFFICIENCY KCB102S4 DEHUMIDIFICATION OPERATING (1ST STAGE)

Entering Wet Bulb Temperature	Total Air Volume	Outdoor Air Temperature Entering Outdoor Coil																				
		65°F						75°F					85°F					95°F				
		Total Cool Cap.	Comp. Motor Input	Sensible To Total Ratio (S/T)			Total Cool Cap.	Comp. Motor Input	Sensible To Total Ratio (S/T)			Total Cool Cap.	Comp. Motor Input	Sensible To Total Ratio (S/T)			Total Cool Cap.	Comp. Motor Input	Sensible To Total Ratio (S/T)			
				Dry Bulb					Dry Bulb					Dry Bulb					Dry Bulb			
cfm	kBtuh	kW	75°F	80°F	85°F	kBtuh	kW	75°F	80°F	85°F	kBtuh	kW	75°F	80°F	85°F	kBtuh	kW	75°F	80°F	85°F		
63°F	2720	35.4	2.2	0.45	0.60	0.74	27.8	2.5	0.22	0.49	0.76	20.2	2.8	-0.02	0.38	0.79	12.6	3.0	-0.25	0.28	0.81	
	3400	39.3	2.2	0.48	0.64	0.80	29.8	2.5	0.21	0.55	0.89	20.2	2.8	-0.07	0.46	0.99	10.7	3.0	-0.34	0.37	1.09	
	4080	43.2	2.2	0.51	0.68	0.85	31.8	2.5	0.20	0.61	1.02	20.3	2.7	-0.11	0.54	1.20	8.9	3.0	-0.43	0.47	1.37	
67°F	2720	40.4	2.2	0.31	0.45	0.59	32.7	2.5	0.08	0.32	0.55	25.0	2.8	-0.14	0.19	0.52	17.3	3.1	-0.37	0.05	0.48	
	3400	44.1	2.2	0.32	0.48	0.64	34.6	2.5	0.05	0.35	0.65	25.0	2.8	-0.23	0.22	0.67	15.5	3.1	-0.51	0.09	0.68	
	4080	47.9	2.2	0.34	0.51	0.69	36.5	2.5	0.01	0.38	0.75	25.1	2.8	-0.32	0.25	0.82	13.7	3.1	-0.65	0.12	0.89	
71°F	2720	45.5	2.2	0.16	0.30	0.44	37.6	2.5	-0.06	0.14	0.34	29.8	2.9	-0.27	-0.01	0.25	21.9	3.2	-0.49	-0.17	0.15	
	3400	49.0	2.2	0.17	0.32	0.48	39.4	2.5	-0.12	0.14	0.41	29.8	2.8	-0.40	-0.03	0.34	20.2	3.1	-0.68	-0.20	0.28	
	4080	52.5	2.2	0.18	0.33	0.52	41.2	2.5	-0.18	0.14	0.48	29.9	2.8	-0.53	-0.05	0.44	18.5	3.1	-0.88	-0.24	0.40	

8.5 TON STANDARD EFFICIENCY KCB102S4 DEHUMIDIFICATION OPERATING (2ND STAGE)

Entering Wet Bulb Temperature	Total Air Volume	Outdoor Air Temperature Entering Outdoor Coil																				
		65°F						75°F					85°F					95°F				
		Total Cool Cap.	Comp. Motor Input	Sensible To Total Ratio (S/T)			Total Cool Cap.	Comp. Motor Input	Sensible To Total Ratio (S/T)			Total Cool Cap.	Comp. Motor Input	Sensible To Total Ratio (S/T)			Total Cool Cap.	Comp. Motor Input	Sensible To Total Ratio (S/T)			
				Dry Bulb					Dry Bulb					Dry Bulb					Dry Bulb			
cfm	kBtuh	kW	75°F	80°F	85°F	kBtuh	kW	75°F	80°F	85°F	kBtuh	kW	75°F	80°F	85°F	kBtuh	kW	75°F	80°F	85°F		
63°F	2720	85.8	4.5	0.61	0.77	0.94	75.7	5.2	0.60	0.78	0.96	65.6	5.9	0.59	0.79	0.98	55.5	6.6	0.58	0.80	1.00	
	3400	91.9	4.5	0.66	0.83	1.00	80.8	5.2	0.65	0.83	1.00	69.7	5.9	0.65	0.84	1.00	58.6	6.6	0.64	0.84	1.00	
	4080	98.0	4.5	0.71	0.89	1.06	85.9	5.2	0.71	0.89	1.04	73.8	5.9	0.70	0.89	1.02	61.7	6.6	0.70	0.89	1.00	
67°F	2720	96.6	4.5	0.47	0.60	0.73	85.7	5.2	0.44	0.59	0.74	74.8	6.0	0.41	0.58	0.74	63.9	6.7	0.38	0.57	0.74	
	3400	102.3	4.5	0.49	0.64	0.79	90.1	5.2	0.47	0.63	0.79	77.8	5.9	0.44	0.62	0.79	65.6	6.7	0.42	0.61	0.78	
	4080	108.1	4.5	0.51	0.68	0.86	94.5	5.2	0.49	0.67	0.85	80.8	5.9	0.47	0.66	0.84	67.2	6.7	0.45	0.65	0.82	
71°F	2720	107.4	4.5	0.33	0.43	0.52	95.7	5.3	0.28	0.40	0.51	84.1	6.0	0.23	0.36	0.50	72.4	6.8	0.18	0.33	0.48	
	3400	112.8	4.5	0.32	0.45	0.59	99.4	5.3	0.28	0.43	0.58	86.0	6.0	0.23	0.40	0.57	72.5	6.7	0.19	0.38	0.57	
	4080	118.2	4.5	0.31	0.48	0.65	103.0	5.3	0.28	0.46	0.65	87.9	6.0	0.24	0.44	0.65	72.7	6.7	0.20	0.42	0.65	

DEHUMIDIFICATION SYSTEM RATINGS

NOTE - For Temperatures and Capacities not shown in tables, see bulletin - Cooling Unit Rating Table Correction Factor Data in Miscellaneous Engineering Data section.

10 TON STANDARD EFFICIENCY WITH KCB120S4 DEHUMIDIFICATION OPERATING (1ST STAGE)

Entering Wet Bulb Temperature	Total Air Volume	Outdoor Air Temperature Entering Outdoor Coil																							
		65°F						75°F						85°F						95°F					
		Total Cool Cap.	Comp. Motor Input	Sensible To Total Ratio (S/T)			Total Cool Cap.	Comp. Motor Input	Sensible To Total Ratio (S/T)			Total Cool Cap.	Comp. Motor Input	Sensible To Total Ratio (S/T)			Total Cool Cap.	Comp. Motor Input	Sensible To Total Ratio (S/T)						
				Dry Bulb					Dry Bulb					Dry Bulb					Dry Bulb						
cfm	kBtuh	kW	75°F	80°F	85°F	kBtuh	kW	75°F	80°F	85°F	kBtuh	kW	75°F	80°F	85°F	kBtuh	kW	75°F	80°F	85°F					
63°F	3200	39.2	2.6	0.51	0.66	0.82	28.3	2.9	0.25	0.60	0.88	17.5	3.2	0.00	0.54	0.94	6.7	3.6	-0.26	0.48	1.00				
	4000	42.7	2.6	0.54	0.72	0.91	29.9	2.9	0.23	0.71	0.94	17.1	3.2	-0.08	0.69	0.97	4.4	3.6	-0.39	0.67	1.00				
	4800	46.3	2.6	0.57	0.78	0.99	31.5	2.9	0.21	0.81	0.99	16.8	3.2	-0.16	0.84	1.00	2.0	3.5	-0.52	0.86	1.00				
67°F	3200	45.5	2.6	0.33	0.48	0.64	34.7	2.9	0.14	0.32	0.50	23.9	3.3	-0.05	0.16	0.36	13.0	3.6	-0.24	-0.01	0.23				
	4000	49.2	2.6	0.36	0.53	0.70	36.4	2.9	0.14	0.34	0.53	23.7	3.3	-0.08	0.14	0.36	10.9	3.6	-0.30	-0.05	0.19				
	4800	52.8	2.6	0.38	0.58	0.77	38.1	2.9	0.13	0.35	0.57	23.4	3.3	-0.11	0.12	0.36	8.7	3.6	-0.36	-0.10	0.16				
71°F	3200	53.5	2.6	0.20	0.33	0.47	41.8	3.0	-0.01	0.18	0.36	30.2	3.3	-0.21	0.02	0.26	18.6	3.7	-0.41	-0.13	0.15				
	4000	56.6	2.6	0.20	0.36	0.52	43.2	3.0	-0.03	0.19	0.40	29.8	3.3	-0.27	0.01	0.29	16.5	3.7	-0.51	-0.16	0.18				
	4800	59.6	2.6	0.21	0.39	0.56	44.6	3.0	-0.06	0.19	0.45	29.5	3.3	-0.33	0.00	0.33	14.4	3.7	-0.60	-0.19	0.21				

10 TON STANDARD EFFICIENCY WITH KCB120S4 DEHUMIDIFICATION OPERATING (2ND STAGE)

Entering Wet Bulb Temperature	Total Air Volume	Outdoor Air Temperature Entering Outdoor Coil																							
		65°F						75°F						85°F						95°F					
		Total Cool Cap.	Comp. Motor Input	Sensible To Total Ratio (S/T)			Total Cool Cap.	Comp. Motor Input	Sensible To Total Ratio (S/T)			Total Cool Cap.	Comp. Motor Input	Sensible To Total Ratio (S/T)			Total Cool Cap.	Comp. Motor Input	Sensible To Total Ratio (S/T)						
				Dry Bulb					Dry Bulb					Dry Bulb					Dry Bulb						
cfm	kBtuh	kW	75°F	80°F	85°F	kBtuh	kW	75°F	80°F	85°F	kBtuh	kW	75°F	80°F	85°F	kBtuh	kW	75°F	80°F	85°F					
63°F	3200	107.2	5.2	0.62	0.76	0.90	92.4	6.0	0.62	0.79	0.93	77.6	6.8	0.61	0.81	0.97	62.8	7.6	0.60	0.84	1.00				
	4000	112.0	5.2	0.67	0.83	0.95	96.4	6.0	0.67	0.86	0.97	80.8	6.8	0.68	0.88	0.98	65.3	7.6	0.68	0.91	1.00				
	4800	116.9	5.2	0.71	0.90	1.00	100.5	6.0	0.73	0.93	1.00	84.1	6.8	0.74	0.95	1.00	67.7	7.6	0.76	0.98	1.00				
67°F	3200	119.0	5.2	0.46	0.59	0.72	103.7	6.0	0.43	0.59	0.74	88.5	6.9	0.41	0.58	0.75	73.2	7.7	0.38	0.57	0.77				
	4000	124.3	5.2	0.49	0.64	0.79	107.0	6.0	0.47	0.64	0.82	89.8	6.9	0.44	0.65	0.85	72.5	7.7	0.42	0.65	0.88				
	4800	129.5	5.2	0.52	0.69	0.86	110.3	6.0	0.50	0.70	0.91	91.0	6.9	0.48	0.72	0.95	71.8	7.7	0.46	0.73	1.00				
71°F	3200	132.8	5.3	0.32	0.44	0.57	116.3	6.1	0.28	0.42	0.57	99.7	7.0	0.23	0.40	0.57	83.2	7.8	0.19	0.38	0.56				
	4000	139.0	5.3	0.34	0.48	0.61	120.4	6.1	0.30	0.46	0.62	101.8	6.9	0.25	0.44	0.63	83.1	7.8	0.20	0.42	0.63				
	4800	145.2	5.3	0.37	0.51	0.66	124.5	6.1	0.32	0.49	0.67	103.8	6.9	0.27	0.48	0.69	83.1	7.8	0.22	0.46	0.70				

12.5 TON STANDARD EFFICIENCY KCB150S4 DEHUMIDIFICATION OPERATING (1ST STAGE)

Entering Wet Bulb Temperature	Total Air Volume	Outdoor Air Temperature Entering Outdoor Coil																							
		65°F						75°F						85°F						95°F					
		Total Cool Cap.	Comp. Motor Input	Sensible To Total Ratio (S/T)			Total Cool Cap.	Comp. Motor Input	Sensible To Total Ratio (S/T)			Total Cool Cap.	Comp. Motor Input	Sensible To Total Ratio (S/T)			Total Cool Cap.	Comp. Motor Input	Sensible To Total Ratio (S/T)						
				Dry Bulb					Dry Bulb					Dry Bulb					Dry Bulb						
cfm	kBtuh	kW	75°F	80°F	85°F	kBtuh	kW	75°F	80°F	85°F	kBtuh	kW	75°F	80°F	85°F	kBtuh	kW	75°F	80°F	85°F					
63°F	3800	55.2	3.4	.48	.70	.91	45.8	3.8	.40	.67	.94	36.4	4.1	.25	.61	.97	27.0	4.5	.33	.51	.99				
	4400	58.2	3.5	.53	.77	1.00	47.9	3.8	.45	.76	1.00	37.6	4.1	.31	.73	1.00	27.3	4.5	.22	.69	1.00				
	5000	61.2	3.5	.57	.84	1.00	50.0	3.8	.50	.85	1.00	38.8	4.1	.33	.73	.90	27.6	4.5	.10	.89	1.00				
67°F	3800	63.7	3.5	.29	.48	.66	53.8	3.9	.20	.41	.63	44.0	4.2	.04	.32	.59	34.1	4.6	.03	.12	.52				
	4400	66.6	3.6	.32	.51	.73	56.1	3.9	.21	.46	.72	45.7	4.2	.05	.36	.68	35.3	4.6	-.04	.19	.65				
	5000	69.4	3.6	.33	.55	.79	58.4	3.9	.24	.51	.79	47.4	4.2	.08	.42	.79	36.4	4.6	-.10	.25	.60				
71°F	3800	72.2	3.6	.15	.31	.47	61.9	4.0	.05	.23	.42	51.6	4.3	-.10	.12	.35	41.3	4.6	-.28	-.07	.22				
	4400	74.9	3.7	.16	.33	.51	64.4	4.0	.05	.25	.45	53.8	4.3	-.11	.14	.39	43.3	4.7	-.29	-.06	.27				
	5000	77.7	3.7	.16	.35	.55	66.9	4.0	.05	.28	.51	56.1	4.4	-.12	.16	.45	45.3	4.7	-.30	-.04	.33				

12.5 TON STANDARD EFFICIENCY KCB150S4 DEHUMIDIFICATION OPERATING (2ND STAGE)

Entering Wet Bulb Temperature	Total Air Volume	Outdoor Air Temperature Entering Outdoor Coil																							
		65°F						75°F						85°F						95°F					
		Total Cool Cap.	Comp. Motor Input	Sensible To Total Ratio (S/T)			Total Cool Cap.	Comp. Motor Input	Sensible To Total Ratio (S/T)			Total Cool Cap.	Comp. Motor Input	Sensible To Total Ratio (S/T)			Total Cool Cap.	Comp. Motor Input	Sensible To Total Ratio (S/T)						
				Dry Bulb					Dry Bulb					Dry Bulb					Dry Bulb						
cfm	kBtuh	kW	75°F	80°F	85°F	kBtuh	kW	75°F	80°F	85°F	kBtuh	kW	75°F	80°F	85°F	kBtuh	kW	75°F	80°F	85°F					
63°F	3800	122.7	7.3	.63	.79	.96	110.6	8.0	.62	.80	.99	98.6	8.8	.61	.81	1.00	86.5	9.6	.60	.82	1.00				
	4400	127.4	7.3	.66	.82	.97	114.4	8.1	.65	.83	1.00	101.4	8.8	.65	.84	1.00	88.4	9.6	.64	.85	1.00				
	5000	132.1	7.3	.69	.84	.99	118.2	8.1	.69	.86	1.00	104.2	8.9	.69	.87	1.00	90.3	9.6	.69	.88	1.00				
67°F	3800	137.7	7.5	.47	.62	.76	124.7	8.2	.44	.61	.78	111.8	9.0	.42	.60	.79	98.8	9.8	.39	.60	.80				
	4400	142.5	7.5	.49	.64	.79	128.7	8.3	.46	.63	.80	115.0	9.0	.44	.63	.81	101.3	9.8	.42	.62	.83				
	5000	147.2	7.6	.50	.66	.81	132.7	8.3	.48	.65	.82	118.2	9.1	.46	.65	.84	103.7	9.8	.44	.65	.85				
71°F	3800	152.7	7.7	.31	.44	.57	138.8	8.4	.27	.42	.56	125.0	9.2	.23	.39	.55	111.1	10.0	.19	.37	.55				
	4400	157.5	7.7	.31	.46	.60	143.1	8.5	.27	.43	.60	128.6	9.2	.23	.41	.59	114.2	10.0	.19	.39	.59				
	5000	162.4	7.8	.31	.47	.63	147.3	8.5	.27	.45	.63	132.2	9.3	.23	.43	.63	117.2	10.0	.19	.41	.63				

BLOWER DATA

092S STANDARD EFFICIENCY BELT DRIVE BLOWER – BASE UNIT

BLOWER TABLE INCLUDES RESISTANCE FOR BASE UNIT ONLY (NO HEAT SECTION) WITH DRY INDOOR COIL AND AIR FILTERS IN PLACE. FOR ALL UNITS ADD:

- 1 – Wet indoor coil air resistance of selected unit.
- 2 – Any factory installed options air resistance (heat section, economizer, etc.)
- 3 – Any field installed accessories air resistance (duct resistance, diffuser, etc.)

Then determine from blower table blower motor output required.

See page 34 for blower motors and drives.

See page 34 for wet coil and option/accessory air resistance data.

MINIMUM AIR VOLUME REQUIRED FOR USE WITH OPTIONAL ELECTRIC HEAT (Maximum Static Pressure - 2.0 in. w.g.)

7.5 kW, 15 kW, 22.5 kW, 30 kW and 45 kW - 2800 cfm

Total Air Volume cfm	Total Static Pressure – in. w.g.																											
	0.2		0.4		0.6		0.8		1.0		1.2		1.4		1.6		1.8		2		2.2		2.4		2.6			
	RPM	BHP	RPM	BHP	RPM	BHP	RPM	BHP	RPM	BHP	RPM	BHP	RPM	BHP	RPM	BHP	RPM	BHP	RPM	BHP	RPM	BHP	RPM	BHP	RPM	BHP	RPM	BHP
1750	608	0.05	651	0.03	696	0.06	744	0.22	794	0.60	845	0.95	894	1.24	934	1.38	978	1.47	1047	1.66	1120	1.89	1179	2.15	1230	2.40		
2000	615	0.07	657	0.05	702	0.10	748	0.36	797	0.72	846	1.05	892	1.30	933	1.45	977	1.55	1049	1.75	1124	2.00	1181	2.23	1234	2.47		
2250	624	0.09	664	0.07	707	0.14	753	0.50	800	0.84	847	1.15	892	1.38	934	1.53	979	1.65	1051	1.86	1126	2.12	1183	2.36	1238	2.62		
2500	632	0.11	672	0.09	714	0.29	758	0.64	803	0.97	849	1.26	893	1.48	936	1.63	983	1.75	1052	1.96	1124	2.22	1184	2.49	1241	2.77		
2750	641	0.13	680	0.11	721	0.45	763	0.78	807	1.09	852	1.37	896	1.58	940	1.74	989	1.88	1053	2.08	1121	2.34	1185	2.63	1244	2.93		
3000	651	0.15	689	0.29	728	0.61	770	0.93	812	1.23	856	1.49	901	1.70	947	1.87	996	2.02	1055	2.21	1120	2.47	1186	2.78	1248	3.10		
3250	661	0.17	698	0.46	737	0.78	777	1.09	819	1.38	862	1.63	908	1.84	955	2.01	1004	2.17	1059	2.36	1122	2.62	1189	2.94	1252	3.28		
3500	672	0.36	708	0.65	746	0.95	786	1.25	827	1.53	870	1.78	916	1.99	965	2.17	1013	2.33	1065	2.52	1126	2.79	1193	3.12	1257	3.47		
3750	684	0.56	719	0.85	756	1.14	795	1.43	836	1.70	880	1.95	927	2.16	976	2.34	1023	2.51	1073	2.71	1133	2.98	1198	3.32	1263	3.67		
4000	697	0.78	731	1.05	768	1.34	807	1.62	848	1.89	892	2.13	940	2.34	988	2.53	1034	2.71	1083	2.91	1141	3.19	1205	3.53	1270	3.89		
4250	710	1.00	745	1.27	781	1.55	819	1.83	861	2.09	906	2.33	954	2.55	1001	2.74	1046	2.93	1094	3.14	1151	3.42	1214	3.76	1278	4.12		

OUTDOOR SOUND DATA

Unit Model Number	Octave Band Sound Power Levels dBA, re 10 ⁻¹² Watts - Center Frequency - Hz							¹ Sound Rating Number (dBA)
	125	250	500	1000	2000	4000	8000	
092, 102 and 120	76	79	84	83	79	73	66	88
150	75	81	87	85	80	73	67	90

Note - The octave sound power data does not include tonal corrections.

¹ Sound Rating Number according to AHRI Standard 270-95 or AHRI Standard 370-2001 (includes pure tone penalty). Sound Rating Number is the overall A-Weighted Sound Power Level, (LWA), dBA (100 Hz to 10,000 Hz).

BLOWER DATA

092H AND 102H HIGH EFFICIENCY BELT DRIVE BLOWER – BASE UNIT

BLOWER TABLE INCLUDES RESISTANCE FOR BASE UNIT ONLY (NO HEAT SECTION) WITH DRY INDOOR COIL AND AIR FILTERS IN PLACE. FOR ALL UNITS ADD:

- 1 – Wet indoor coil air resistance of selected unit.
- 2 – Any factory installed options air resistance (heat section, economizer, etc.)
- 3 – Any field installed accessories air resistance (duct resistance, diffuser, etc.)

Then determine from blower table blower motor output required.

See page 34 for blower motors and drives.

See page 34 for wet coil and option/accessory air resistance data.

MINIMUM AIR VOLUME REQUIRED FOR USE WITH OPTIONAL ELECTRIC HEAT (Maximum Static Pressure - 2.0 in. w.g.)

7.5 kW, 15 kW, 22.5 kW, 30 kW and 45 kW - 2800 cfm

Total Air Volume cfm	Total Static Pressure – in. w.g.																									
	0.2		0.4		0.6		0.8		1.0		1.2		1.4		1.6		1.8		2.0		2.2		2.4		2.6	
	RPM	BHP	RPM	BHP	RPM	BHP	RPM	BHP	RPM	BHP	RPM	BHP	RPM	BHP	RPM	BHP	RPM	BHP	RPM	BHP	RPM	BHP	RPM	BHP	RPM	BHP
1750	481	0.21	549	0.4	618	0.57	688	0.7	758	0.82	824	0.93	885	1.08	941	1.23	991	1.39	1038	1.54	1082	1.68	1124	1.82	1166	1.95
2000	493	0.29	561	0.47	629	0.64	700	0.77	768	0.9	832	1.02	892	1.17	946	1.33	995	1.49	1041	1.66	1085	1.81	1126	1.97	1167	2.12
2250	507	0.37	574	0.56	643	0.72	712	0.86	779	0.99	842	1.13	900	1.28	953	1.44	1001	1.61	1045	1.78	1088	1.95	1128	2.12	1168	2.3
2500	521	0.46	588	0.64	657	0.81	727	0.95	792	1.09	853	1.24	909	1.4	960	1.57	1007	1.74	1050	1.93	1091	2.11	1130	2.29	1170	2.48
2750	537	0.56	604	0.74	674	0.91	743	1.06	806	1.21	865	1.36	920	1.53	969	1.71	1014	1.89	1055	2.08	1095	2.27	1133	2.47	1172	2.66
3000	554	0.67	622	0.86	692	1.02	760	1.18	822	1.34	878	1.5	931	1.68	979	1.86	1021	2.06	1061	2.26	1099	2.46	1136	2.65	1174	2.85
3250	572	0.78	641	0.98	712	1.15	778	1.32	838	1.49	892	1.66	943	1.84	989	2.03	1030	2.24	1068	2.45	1105	2.65	1141	2.85	1178	3.06
3500	592	0.9	663	1.12	733	1.3	798	1.47	855	1.65	907	1.83	956	2.02	1000	2.22	1039	2.44	1076	2.65	1111	2.86	1146	3.07	1183	3.27
3750	614	1.04	687	1.28	756	1.47	818	1.65	872	1.83	923	2.02	970	2.22	1011	2.43	1049	2.65	1084	2.87	1118	3.09	1152	3.29	1189	3.51
4000	639	1.22	713	1.48	780	1.66	838	1.83	890	2.02	939	2.22	984	2.44	1023	2.66	1059	2.89	1093	3.11	1126	3.33	1160	3.54	1197	3.77
4250	667	1.43	741	1.69	805	1.86	859	2.02	909	2.22	956	2.45	998	2.68	1036	2.92	1070	3.15	1103	3.37	1135	3.59	1169	3.81	1207	4.05

BLOWER DATA

102S AND 120S SINGLE ZONE VAV SUPPLY FAN STANDARD EFFICIENCY BELT DRIVE BLOWER – BASE UNIT

BLOWER TABLE INCLUDES RESISTANCE FOR BASE UNIT ONLY (NO HEAT SECTION) WITH DRY INDOOR COIL AND AIR FILTERS IN PLACE. FOR ALL UNITS ADD:

- 1 – Wet indoor coil air resistance of selected unit.
- 2 – Any factory installed options air resistance (heat section, economizer, etc.)
- 3 – Any field installed accessories air resistance (duct resistance, diffuser, etc.)

Then determine from blower table blower motor output required.

See page 34 for blower motors and drives.

See page 34 for wet coil and option/accessory air resistance data.

MINIMUM AIR VOLUME REQUIRED FOR USE WITH OPTIONAL ELECTRIC HEAT (Maximum Static Pressure - 2.0 in. w.g.)

15 kW, 22.5 kW, 30 kW and 45 kW - 2800 cfm

60 kW - 4000 cfm

Total Air Volume cfm	Total Static Pressure – in. w.g.																										
	0.2		0.4		0.6		0.8		1.0		1.2		1.4		1.6		1.8		2		2.2		2.4		2.6		
	RPM	BHP	RPM	BHP	RPM	BHP	RPM	BHP	RPM	BHP	RPM	BHP	RPM	BHP	RPM	BHP	RPM	BHP	RPM	BHP	RPM	BHP	RPM	BHP	RPM	BHP	RPM
2000	593	0.11	636	0.07	682	0.10	731	0.22	784	0.60	840	0.96	898	1.26	948	1.38	996	1.47	1045	1.57	1092	1.71	1140	1.92	1188	2.32	
2250	604	0.15	645	0.11	690	0.15	739	0.39	790	0.74	846	1.08	901	1.34	953	1.48	1002	1.57	1052	1.70	1100	1.86	1149	2.09	1197	2.42	
2500	615	0.19	655	0.15	699	0.20	747	0.55	797	0.89	851	1.20	906	1.44	959	1.58	1009	1.68	1059	1.83	1108	2.01	1158	2.26	1206	2.52	
2750	626	0.23	666	0.19	709	0.37	755	0.71	805	1.03	858	1.32	912	1.55	966	1.70	1017	1.81	1067	1.97	1117	2.17	1166	2.44	1215	2.71	
3000	637	0.27	677	0.24	719	0.55	764	0.87	813	1.18	866	1.45	920	1.67	975	1.82	1026	1.96	1076	2.13	1126	2.35	1176	2.63	1225	2.92	
3250	650	0.31	688	0.43	730	0.73	775	1.04	823	1.34	875	1.60	930	1.81	985	1.97	1036	2.12	1086	2.31	1136	2.54	1186	2.83	1235	3.13	
3500	663	0.35	700	0.63	741	0.92	786	1.22	834	1.50	886	1.76	942	1.96	997	2.14	1048	2.31	1097	2.51	1147	2.75	1196	3.04	1245	3.35	
3750	676	0.57	714	0.84	754	1.12	798	1.41	846	1.68	899	1.93	956	2.14	1010	2.32	1060	2.51	1109	2.72	1158	2.98	1207	3.27	1255	3.58	
4000	691	0.79	728	1.05	768	1.33	812	1.61	860	1.88	914	2.12	971	2.34	1023	2.53	1072	2.73	1121	2.95	1169	3.22	1218	3.51	1266	3.83	
4250	706	1.03	743	1.28	783	1.55	827	1.82	876	2.09	931	2.33	987	2.55	1037	2.76	1085	2.97	1133	3.20	1181	3.47	1229	3.76	1277	4.08	
4500	722	1.27	759	1.52	799	1.78	844	2.05	894	2.31	949	2.56	1003	2.79	1052	3.00	1098	3.22	1145	3.46	1193	3.73	1241	4.03	1289	4.34	
4750	739	1.53	776	1.77	817	2.03	862	2.30	913	2.56	968	2.81	1020	3.04	1066	3.27	1112	3.49	1158	3.74	1205	4.01	1253	4.30	1301	4.61	
5000	757	1.79	794	2.04	835	2.30	882	2.56	934	2.83	988	3.08	1036	3.32	1081	3.55	1125	3.78	1171	4.02	1218	4.29	1265	4.59	1312	4.89	

BLOWER DATA

120H AND 120S (CAV) HIGH EFFICIENCY AND 150S STANDARD EFFICIENCY BELT DRIVE BLOWER – BASE UNIT
BLOWER TABLE INCLUDES RESISTANCE FOR BASE UNIT ONLY (NO HEAT SECTION) WITH DRY INDOOR COIL AND AIR FILTERS IN PLACE. FOR ALL UNITS ADD:

- 1 – Wet indoor coil air resistance of selected unit.
- 2 – Any factory installed options air resistance (heat section, economizer, etc.)
- 3 – Any field installed accessories air resistance (duct resistance, diffuser, etc.)

Then determine from blower table blower motor output required.

See page 34 for blower motors and drives.

See page 34 for wet coil and option/accessory air resistance data.

MINIMUM AIR VOLUME REQUIRED FOR USE WITH OPTIONAL ELECTRIC HEAT (Maximum Static Pressure - 2.0 in. w.g.)

15 kW, 22.5 kW, 30 kW and 45 kW - 2800 cfm

60 kW - 4000 cfm

Total Air Volume cfm	Total Static Pressure – in. w.g.																										
	0.2		0.4		0.6		0.8		1.0		1.2		1.4		1.6		1.8		2.0		2.2		2.4		2.6		
	RPM	BHP	RPM	BHP	RPM	BHP	RPM	BHP	RPM	BHP	RPM	BHP	RPM	BHP	RPM	BHP	RPM	BHP	RPM	BHP	RPM	BHP	RPM	BHP	RPM	BHP	RPM
2000	497	0.25	558	0.44	624	0.6	694	0.74	764	0.85	830	0.99	889	1.16	943	1.34	994	1.52	1045	1.71	1096	1.89	1146	2.08	1197	2.27	
2250	511	0.34	573	0.52	638	0.68	708	0.82	776	0.94	839	1.09	896	1.26	948	1.45	998	1.64	1048	1.83	1098	2.01	1149	2.2	1200	2.4	
2500	527	0.44	589	0.62	654	0.78	723	0.91	789	1.05	850	1.21	904	1.39	955	1.58	1003	1.77	1052	1.96	1101	2.14	1152	2.33	1203	2.53	
2750	545	0.55	606	0.72	672	0.88	740	1.03	804	1.17	861	1.34	914	1.53	962	1.72	1010	1.92	1057	2.10	1105	2.29	1154	2.47	1206	2.68	
3000	564	0.66	626	0.84	692	1.01	759	1.16	819	1.32	874	1.49	924	1.68	971	1.88	1017	2.08	1063	2.26	1110	2.44	1158	2.63	1208	2.83	
3250	585	0.79	648	0.98	714	1.14	778	1.31	836	1.48	887	1.66	935	1.86	981	2.06	1026	2.26	1071	2.45	1117	2.63	1163	2.80	1213	3.00	
3500	607	0.93	672	1.13	737	1.31	798	1.48	852	1.66	901	1.85	948	2.05	993	2.26	1037	2.46	1081	2.65	1125	2.83	1171	3.01	1221	3.21	
3750	632	1.10	698	1.31	762	1.50	819	1.67	869	1.86	915	2.05	961	2.25	1005	2.47	1049	2.68	1092	2.88	1136	3.05	1181	3.24	1231	3.45	
4000	660	1.30	726	1.52	787	1.70	838	1.87	885	2.06	930	2.26	974	2.48	1018	2.71	1062	2.93	1105	3.12	1149	3.30	1194	3.49	1245	3.72	
4250	691	1.53	755	1.75	810	1.91	857	2.07	901	2.27	945	2.50	990	2.74	1034	2.98	1077	3.20	1120	3.39	1163	3.58	1210	3.79	1262	4.03	
4500	724	1.78	783	1.98	831	2.12	874	2.28	917	2.50	962	2.75	1006	3.02	1051	3.27	1094	3.49	1137	3.70	1181	3.89	1228	4.11	1281	4.38	
4750	757	2.05	809	2.20	851	2.33	891	2.51	935	2.76	980	3.05	1025	3.33	1070	3.59	1113	3.82	1156	4.03	1201	4.24	1249	4.47	1303	4.75	
5000	787	2.31	831	2.43	870	2.57	910	2.78	954	3.06	1000	3.38	1046	3.68	1091	3.95	1135	4.19	1178	4.40	1224	4.62	1272	4.86	1325	5.13	
5250	814	2.55	852	2.66	889	2.83	930	3.09	975	3.41	1023	3.76	1070	4.08	1115	4.35	1159	4.59	1203	4.81	1248	5.03	1297	5.27	1350	5.53	
5500	835	2.78	871	2.91	909	3.13	952	3.44	999	3.81	1049	4.18	1096	4.51	1142	4.79	1186	5.03	1229	5.24	1275	5.46	1324	5.69	---	---	
5750	854	3.01	890	3.19	930	3.48	977	3.86	1027	4.27	1078	4.66	1126	4.99	1171	5.26	1214	5.49	1258	5.70	---	---	---	---	---	---	
6000	871	3.26	910	3.53	955	3.90	1006	4.34	1060	4.80	1111	5.19	1158	5.51	---	---	---	---	---	---	---	---	---	---	---	---	
6250	890	3.57	934	3.94	985	4.41	1041	4.91	1096	5.38	---	---	---	---	---	---	---	---	---	---	---	---	---	---	---	---	

BLOWER DATA

FACTORY INSTALLED BELT DRIVE KIT SPECIFICATIONS

Nominal hp	Maximum hp	Drive Kit Number	RPM Range
2	2.3	1	590 - 890
2	2.3	2	800 - 1105
2	2.3	3	795 - 1195
3	3.45	4	730 - 970
3	3.45	5	940 - 1200
3	3.45	6	1015 - 1300
5	5.75	10	900 - 1135
5	5.75	11	1040 - 1315
5	5.75	12	1125 - 1425

NOTE - Using total air volume and system static pressure requirements determine from blower performance tables rpm and motor output required. Maximum usable output of motors furnished are shown. In Canada, nominal motor output is also maximum usable motor output. If motors of comparable output are used, be sure to keep within the service factor limitations outlined on the motor nameplate.

NOTE – Units equipped with Single Zone VAV Supply Fan option are limited to a motor service factor of 1.0.

POWER EXHAUST FAN PERFORMANCE

Return Air System Static Pressure	Air Volume Exhausted
in. w.g.	cfm
0	3175
0.05	2955
0.10	2685
0.15	2410
0.20	2165
0.25	1920
0.30	1420
0.35	1200

FACTORY INSTALLED OPTIONS/FIELD INSTALLED ACCESSORY AIR RESISTANCE - in. w.g.

Air Volume cfm	Wet Indoor Coil		Electric Heat	Economizer	Dehumidification Condenser Reheat Coil	Filters		Return Air Adaptor Plate
	092, 102	120, 150				MERV 8	MERV 13	
1750	0.04	0.04	0.03	0.05	0.02	0.01	0.03	0.00
2000	0.05	0.05	0.03	0.06	0.02	0.01	0.03	0.00
2250	0.06	0.06	0.04	0.08	0.02	0.01	0.04	0.00
2500	0.07	0.07	0.04	0.11	0.03	0.01	0.05	0.00
2750	0.08	0.08	0.05	0.12	0.03	0.02	0.05	0.00
3000	0.10	0.09	0.06	0.13	0.03	0.02	0.06	0.02
3250	0.11	0.10	0.06	0.15	0.04	0.02	0.06	0.02
3500	0.12	0.11	0.09	0.15	0.04	0.03	0.07	0.04
3750	0.14	0.13	0.09	0.15	0.05	0.03	0.08	0.07
4000	0.15	0.14	0.09	0.19	0.05	0.04	0.08	0.09
4250	0.17	0.15	0.13	0.19	0.06	0.04	0.09	0.11
4500	0.19	0.17	0.14	0.22	0.07	0.04	0.09	0.12
4750	0.20	0.18	0.17	0.25	0.07	0.05	0.10	0.16
5000	0.22	0.20	0.20	0.29	0.08	0.06	0.10	0.18
5250	0.24	0.22	0.22	0.32	0.08	0.06	0.11	0.19
5500	0.25	0.23	0.25	0.34	0.09	0.07	0.12	0.22
5750	0.27	0.25	0.31	0.45	0.10	0.07	0.12	0.25
6000	0.29	0.27	0.33	0.52	0.10	0.08	0.13	0.27

BLOWER DATA

CEILING DIFFUSERS AIR RESISTANCE - in. w.g.

Unit Size	RTD11 Step-Down Diffuser				FD11 Flush Diffuser
	Air Volume cfm	2 Ends Open	1 Side, 2 Ends Open	All Ends & Sides Open	
092 Models	2400	0.21	0.18	0.15	0.14
	2600	0.24	0.21	0.18	0.17
	2800	0.27	0.24	0.21	0.20
	3000	0.32	0.29	0.25	0.25
	3200	0.41	0.37	0.32	0.31
	3400	0.50	0.45	0.39	0.37
	3600	0.61	0.54	0.48	0.44
102 & 120 Models	3800	0.73	0.63	0.57	0.51
	3600	0.36	0.28	0.23	0.15
	3800	0.40	0.32	0.26	0.18
	4000	0.44	0.36	0.29	0.21
	4200	0.49	0.40	0.33	0.24
	4400	0.54	0.44	0.37	0.27
	4600	0.60	0.49	0.42	0.31
	4800	0.65	0.53	0.46	0.35
150 Models	5000	0.69	0.58	0.50	0.39
	5200	0.75	0.62	0.54	0.43
	4200	0.22	0.19	0.16	0.10
	4400	0.28	0.24	0.20	0.12
	4600	0.34	0.29	0.24	0.15
	4800	0.40	0.34	0.29	0.19
	5000	0.46	0.39	0.34	0.23
	5200	0.52	0.44	0.39	0.27
	5400	0.58	0.49	0.43	0.31
5600	0.64	0.54	0.47	0.35	
5800	0.70	0.59	0.51	0.39	

CEILING DIFFUSER AIR THROW DATA

Model No.	Air Volume cfm	¹ Effective Throw Range	
		RTD11 Step-Down	FD11 Flush
		ft.	ft.
092 Models	2600	24 - 29	19 - 24
	2800	25 - 30	20 - 28
	3000	27 - 33	21 - 29
	3200	28 - 35	22 - 29
	3400	30 - 37	22 - 30
102, 120 Models	3600	25 - 33	22 - 29
	3800	27 - 35	22 - 30
	4000	29 - 37	24 - 33
	4200	32 - 40	26 - 35
	4400	34 - 42	28 - 37
150 Models	5600	39 - 49	28 - 37
	5800	42 - 51	29 - 38
	6000	44 - 54	40 - 50
	6200	45 - 55	42 - 51
	6400	46 - 55	43 - 52
6600	47 - 56	45 - 56	

¹ Throw is the horizontal or vertical distance an air stream travels on leaving the outlet or diffuser before the maximum velocity is reduced to 50 ft. per minute. Four sides open.

ELECTRICAL/ELECTRIC HEAT DATA

7.5 TON

7.5 TON STANDARD EFFICIENCY (R-410A)

KCB092S4

¹ Voltage - 60hz		208/230V - 3 Ph			460V - 3 Ph			575V - 3 Ph		
Compressor 1	Rated Load Amps	13.1			6.1			4.4		
	Locked Rotor Amps	83.1			41			33		
Compressor 2	Rated Load Amps	13.1			6.1			4.4		
	Locked Rotor Amps	83.1			41			33		
Outdoor Fan Motors (2)	Full Load Amps (total)	2.4 (4.8)			1.3 (2.6)			1 (2)		
Power Exhaust (1) 0.33 HP	Full Load Amps	2.4			1.3			1		
Service Outlet 115V GFI (amps)		15			15			20		
Indoor Blower Motor	Horsepower	2	3	5	2	3	5	2	3	5
	Full Load Amps	7.5	10.5	16.7	3.4	4.8	7.6	2.7	3.9	6.1
² Maximum Overcurrent Protection	Unit Only With (1) 0.33 HP Power Exhaust	50	50	60	25	25	30	15	20	20
³ Minimum Circuit Ampacity	Unit Only With (1) 0.33 HP Power Exhaust	42	45	52	20	22	25	15	16	19

ELECTRIC HEAT DATA

Electric Heat Voltage			208V	240V	208V	240V	208V	240V	480V	480V	480V	600V	600V	600V
² Maximum Overcurrent Protection	Unit+ Electric Heat	7.5 kW	50	50	50	50	60	60	25	25	30	15	20	20
	and (1) 0.33 HP Power Exhaust	15 kW	50	60	60	60	60	70	30	30	35	25	25	30
		22.5 kW	70	80	80	90	80	90	40	40	45	35	35	35
		30 kW	90	100	100	110	100	125	50	60	60	40	45	45
	45 kW	150	150	150	150	150	175	80	80	80	60	60	70	
³ Minimum Circuit Ampacity	Unit+ Electric Heat	7.5 kW	42	42	45	45	52	52	20	22	25	15	16	19
	and (1) 0.33 HP Power Exhaust	15 kW	49	55	53	59	60	66	27	29	33	22	23	26
		22.5 kW	69	78	72	81	80	89	39	40	44	31	32	35
		30 kW	88	100	92	104	100	112	50	52	55	40	41	44
	45 kW	127	145	131	149	139	157	72	74	78	58	60	62	
² Maximum Overcurrent Protection	Unit+ Electric Heat	7.5 kW	50	50	60	60	70	70	25	25	30	20	20	25
	and (1) 0.33 HP Power Exhaust	15 kW	60	60	60	70	70	70	30	35	35	25	25	30
		22.5 kW	80	90	80	90	90	100	40	45	45	35	35	40
		30 kW	100	110	100	110	110	125	60	60	60	45	45	45
	45 kW	150	150	150	175	150	175	80	80	80	60	70	70	
³ Minimum Circuit Ampacity	Unit+ Electric Heat	7.5 kW	45	45	48	48	55	55	22	23	26	16	17	20
	and (1) 0.33 HP Power Exhaust	15 kW	52	58	56	62	63	69	29	31	34	23	25	27
		22.5 kW	72	81	75	84	83	92	40	42	45	32	34	36
		30 kW	91	103	95	107	103	115	51	53	57	41	43	45
	45 kW	130	148	134	152	142	160	74	76	79	59	61	64	

ELECTRICAL ACCESSORIES

Disconnect	7.5 kW	54W56	54W56	54W56
	15 kW	54W56	54W56	54W56
	22.5 kW	54W56	54W56	54W56
	30 kW	54W57	54W56	54W56
	45 kW	54W57	54W56	54W56

NOTE - All units have a minimum Short Circuit Current Rating (SCCR) of 5000 amps.

¹ Extremes of operating range are plus and minus 10% of line voltage.

² HACR type breaker or fuse.

³ Refer to National or Canadian Electrical Code manual to determine wire, fuse and disconnect size requirements.

ELECTRICAL/ELECTRIC HEAT DATA

7.5 TON

7.5 TON HIGH EFFICIENCY (R-410A)

KCA092H4

¹ Voltage - 60hz		208/230V - 3 Ph			460V - 3 Ph			575V - 3 Ph		
Compressor 1	Rated Load Amps	13.1			6.1			4.4		
	Locked Rotor Amps	83.1			41			33		
Compressor 2	Rated Load Amps	13.1			6.1			4.4		
	Locked Rotor Amps	83.1			41			33		
Outdoor Fan Motors (2)	Full Load Amps (total)	2.4 (4.8)			1.3 (2.6)			1 (2)		
Power Exhaust (1) 0.33 HP	Full Load Amps	2.4			1.3			1		
Service Outlet 115V GFI (amps)		15			15			20		
Indoor Blower Motor	Horsepower	2	3	5	2	3	5	2	3	5
	Full Load Amps	7.5	10.6	16.7	3.4	4.8	7.6	2.7	3.9	6.1
² Maximum Overcurrent Protection	Unit Only With (1) 0.33 HP Power Exhaust	50	50	60	25	25	30	15	20	20
³ Minimum Circuit Ampacity	Unit Only With (1) 0.33 HP Power Exhaust	42	45	52	20	22	25	15	16	19

ELECTRIC HEAT DATA

Electric Heat Voltage			208V	240V	208V	240V	208V	240V	480V	480V	480V	600V	600V	600V
² Maximum Overcurrent Protection	Unit+ 7.5 kW	Electric Heat	50	50	50	50	60	60	25	25	30	15	20	20
	15 kW		50	60	60	60	60	70	30	30	35	25	25	30
	22.5 kW		70	80	80	90	80	90	40	40	45	35	35	35
	30 kW		90	100	100	110	100	125	50	60	60	40	45	45
	45 kW		150	150	150	150	150	175	80	80	80	60	60	70
³ Minimum Circuit Ampacity	Unit+ 7.5 kW	Electric Heat	42	42	45	45	52	52	20	22	25	15	16	19
	15 kW		49	55	53	59	60	66	27	29	33	22	23	26
	22.5 kW		69	78	72	81	80	89	39	40	44	31	32	35
	30 kW		88	100	92	104	100	112	50	52	55	40	41	44
	45 kW		127	145	131	149	139	157	72	74	78	58	60	62
² Maximum Overcurrent Protection	Unit+ 7.5 kW	Electric Heat	50	50	60	60	70	70	25	25	30	20	20	25
	15 kW		60	60	60	70	70	70	30	35	35	25	25	30
	22.5 kW		80	90	80	90	90	100	40	45	45	35	35	40
	30 kW		100	110	100	110	110	125	60	60	60	45	45	45
	45 kW		150	150	150	175	150	175	80	80	80	60	70	70
³ Minimum Circuit Ampacity	Unit+ 7.5 kW	Electric Heat	45	45	48	48	55	55	22	23	26	16	17	20
	15 kW		52	58	56	62	63	69	29	31	34	23	25	27
	22.5 kW		72	81	75	84	83	92	40	42	45	32	34	36
	30 kW		91	103	95	107	103	115	51	53	57	41	43	45
	45 kW		130	148	134	152	142	160	74	76	79	59	61	64

ELECTRICAL ACCESSORIES

Disconnect	7.5 kW	54W56			54W56		
	15 kW	54W56			54W56		
	22.5 kW	54W56	54W57		54W56		
	30 kW	54W57			54W56		
	45 kW	54W57			54W56		

NOTE - All units have a minimum Short Circuit Current Rating (SCCR) of 5000 amps.

¹ Extremes of operating range are plus and minus 10% of line voltage.

² HACR type breaker or fuse.

³ Refer to National or Canadian Electrical Code manual to determine wire, fuse and disconnect size requirements.

ELECTRICAL/ELECTRIC HEAT DATA

8.5 TON

8.5 TON STANDARD EFFICIENCY (R-410A)

KCB102S4

¹ Voltage - 60hz		208/230V - 3 Ph			460V - 3 Ph			575V - 3 Ph		
Compressor 1	Rated Load Amps	11.9			6.7			5.4		
	Locked Rotor Amps	109			59			40		
Compressor 2	Rated Load Amps	11.9			6.7			5.4		
	Locked Rotor Amps	109			59			40		
Outdoor Fan Motors (2)	Full Load Amps (total)	2.4 (4.8)			1.3 (2.6)			1 (2)		
Power Exhaust (1) 0.33 HP	Full Load Amps	2.4			1.3			1		
Service Outlet 115V GFI (amps)		15			15			20		
Indoor Blower Motor	Horsepower	2	3	5	2	3	5	2	3	5
	Full Load Amps	7.5	10.6	16.7	3.4	4.8	7.6	2.7	3.9	6.1
² Maximum Overcurrent Protection	Unit Only	50	50	60	25	25	30	20	20	25
With (1) 0.33 HP Power Exhaust	With (1) 0.33 HP	50	50	60	25	30	30	20	20	25
	Power Exhaust									
³ Minimum Circuit Ampacity	Unit Only	40	43	50	22	23	26	17	19	21
With (1) 0.33 HP Power Exhaust	With (1) 0.33 HP	42	45	52	23	24	27	18	20	22
	Power Exhaust									

ELECTRIC HEAT DATA

Electric Heat Voltage			208V	240V	208V	240V	208V	240V	480V	480V	480V	600V	600V	600V
² Maximum Overcurrent Protection	Unit+ Electric Heat	7.5 kW	50	50	50	50	60	60	25	25	30	20	20	25
and (1) 0.33 HP Power Exhaust	Electric Heat	15 kW	⁴ 50	60	60	60	⁴ 60	70	30	30	35	25	25	30
		22.5 kW	⁴ 70	80	⁴ 80	90	⁴ 80	90	40	40	45	35	35	35
		30 kW	⁴ 90	100	⁴ 100	110	⁴ 100	125	50	60	60	40	45	45
		45 kW	150	150	150	150	⁴ 150	175	80	80	80	60	60	70
³ Minimum Circuit Ampacity	Unit+ Electric Heat	7.5 kW	40	40	43	43	50	50	22	23	26	17	19	21
and (1) 0.33 HP Power Exhaust	Electric Heat	15 kW	49	55	53	59	60	66	27	29	33	22	23	26
		22.5 kW	69	78	72	81	80	89	39	40	44	31	32	35
		30 kW	88	100	92	104	100	112	50	52	55	40	41	44
		45 kW	127	145	131	149	139	157	72	74	78	58	60	62
² Maximum Overcurrent Protection	Unit+ Electric Heat	7.5 kW	50	50	50	50	60	60	25	30	30	20	20	25
and (1) 0.33 HP Power Exhaust	Electric Heat	15 kW	60	60	⁴ 60	70	70	70	30	35	35	25	25	30
		22.5 kW	⁴ 80	90	⁴ 80	90	⁴ 90	100	40	45	45	35	35	40
		30 kW	⁴ 100	110	⁴ 100	110	⁴ 110	125	60	60	60	45	45	45
		45 kW	150	150	⁴ 150	175	⁴ 150	175	80	80	80	60	70	70
³ Minimum Circuit Ampacity	Unit+ Electric Heat	7.5 kW	42	42	45	45	52	52	23	24	27	18	20	22
and (1) 0.33 HP Power Exhaust	Electric Heat	15 kW	52	58	56	62	63	69	29	31	34	23	25	27
		22.5 kW	72	81	75	84	83	92	40	42	45	32	34	36
		30 kW	91	103	95	107	103	115	51	53	57	41	43	45
		45 kW	130	148	134	152	142	160	74	76	79	59	61	64

ELECTRICAL ACCESSORIES

Disconnect	7.5 kW	54W56			54W56			54W56		
	15 kW	54W56			54W56			54W56		
	22.5 kW	54W56			54W56			54W56		
	30 kW	54W57			54W56			54W56		
	45 kW	54W57			54W56			54W56		

NOTE - All units have a minimum Short Circuit Current Rating (SCCR) of 5000 amps.

¹ Extremes of operating range are plus and minus 10% of line voltage.

² HACR type breaker or fuse.

³ Refer to National or Canadian Electrical Code manual to determine wire, fuse and disconnect size requirements.

ELECTRICAL/ELECTRIC HEAT DATA

8.5 TON

8.5 TON HIGH EFFICIENCY (R-410A)

KCA102H4

¹ Voltage - 60hz		208/230V - 3 Ph			460V - 3 Ph			575V - 3 Ph		
Compressor 1	Rated Load Amps	13.7			6.2			4.8		
	Locked Rotor Amps	83.1			41			33		
Compressor 2	Rated Load Amps	13.7			6.2			4.8		
	Locked Rotor Amps	83.1			41			33		
Outdoor Fan Motors (2)	Full Load Amps (total)	2.4 (4.8)			1.3 (2.6)			1 (2)		
Power Exhaust (1) 0.33 HP	Full Load Amps	2.4			1.3			1		
Service Outlet 115V GFI (amps)		15			15			20		
Indoor Blower Motor	Horsepower	2	3	5	2	3	5	2	3	5
	Full Load Amps	7.5	10.6	16.7	3.4	4.8	7.6	2.7	3.9	6.1
² Maximum Overcurrent Protection	Unit Only With (1) 0.33 HP Power Exhaust	50	50	60	25	25	30	20	20	25
³ Minimum Circuit Ampacity	Unit Only With (1) 0.33 HP Power Exhaust	44	47	54	20	22	25	16	17	20

ELECTRIC HEAT DATA

Electric Heat Voltage			208V	240V	208V	240V	208V	240V	480V	480V	480V	600V	600V	600V
² Maximum Overcurrent Protection	Unit+ Electric Heat	7.5 kW	50	50	50	50	60	60	25	25	30	20	20	25
		15 kW	50	60	60	60	60	70	30	30	35	25	25	30
		22.5 kW	70	80	80	90	80	90	40	40	45	35	35	35
		30 kW	90	100	100	110	100	125	50	60	60	40	45	45
		45 kW	150	150	150	150	150	175	80	80	80	60	60	70
³ Minimum Circuit Ampacity	Unit+ Electric Heat	7.5 kW	44	44	47	47	54	54	20	22	25	16	17	20
		15 kW	49	55	53	59	60	66	27	29	33	22	23	26
		22.5 kW	69	78	72	81	80	89	39	40	44	31	32	35
		30 kW	88	100	92	104	100	112	50	52	55	40	41	44
		45 kW	127	145	131	149	139	157	72	74	78	58	60	62
² Maximum Overcurrent Protection	Unit+ Electric Heat	7.5 kW	50	50	60	60	70	70	25	25	30	20	20	25
		15 kW	60	60	60	70	70	70	30	35	35	25	25	30
		22.5 kW and (1) 0.33 HP	80	90	80	90	90	100	40	45	45	35	35	40
		30 kW	100	110	100	110	110	125	60	60	60	45	45	45
		45 kW Power Exhaust	150	150	150	175	150	175	80	80	80	60	70	70
³ Minimum Circuit Ampacity	Unit+ Electric Heat	7.5 kW	46	46	49	49	56	56	22	23	26	17	18	21
		15 kW	52	58	56	62	63	69	29	31	34	23	25	27
		22.5 kW and (1) 0.33 HP	72	81	75	84	83	92	40	42	45	32	34	36
		30 kW	91	103	95	107	103	115	51	53	57	41	43	45
		45 kW Power Exhaust	130	148	134	152	142	160	74	76	79	59	61	64

ELECTRICAL ACCESSORIES

Disconnect	7.5 kW	54W56			54W56		
	15 kW	54W56			54W56		
	22.5 kW	54W56	54W57		54W56		
	30 kW	54W57			54W56		
	45 kW	54W57			54W56		

NOTE - All units have a minimum Short Circuit Current Rating (SCCR) of 5000 amps.

¹ Extremes of operating range are plus and minus 10% of line voltage.

² HACR type breaker or fuse.

³ Refer to National or Canadian Electrical Code manual to determine wire, fuse and disconnect size requirements.

ELECTRICAL/ELECTRIC HEAT DATA

10 TON

10 TON STANDARD EFFICIENCY (R-410A)

KCB120S4

¹ Voltage - 60hz		208/230V - 3 Ph			460V - 3 Ph			575V - 3 Ph		
Compressor 1	Rated Load Amps	13.5			8			5		
	Locked Rotor Amps	109			59			40		
Compressor 2	Rated Load Amps	13.5			8			5		
	Locked Rotor Amps	109			59			40		
Outdoor Fan Motors (2)	Full Load Amps (total)	2.4 (4.8)			1.3 (2.6)			1 (2)		
Power Exhaust (1) 0.33 HP	Full Load Amps	2.4			1.3			1		
Service Outlet 115V GFI (amps)		15			15			20		
Indoor Blower Motor	Horsepower	2	3	5	2	3	5	2	3	5
	Full Load Amps	7.5	10.6	16.7	3.4	4.8	7.6	2.7	3.9	6.1
² Maximum Overcurrent Protection	Unit Only With (1) 0.33 HP Power Exhaust	50	50	60	30	30	35	20	20	25
³ Minimum Circuit Ampacity	Unit Only With (1) 0.33 HP Power Exhaust	43	46	53	24	26	29	16	18	20

ELECTRIC HEAT DATA

Electric Heat Voltage			208V	240V	208V	240V	208V	240V	480V	480V	480V	600V	600V	600V
² Maximum Overcurrent Protection	Unit+ 15 kW	Electric Heat	50	60	60	60	60	70	30	30	35	25	25	30
	22.5 kW		70	80	80	90	80	90	40	40	45	35	35	35
	30 kW		90	100	100	110	100	125	50	60	60	40	45	45
	45 kW		150	150	150	150	150	175	80	80	80	60	60	70
	60 kW		150	175	150	175	150	175	80	80	90	70	70	70
³ Minimum Circuit Ampacity	Unit+ 15 kW	Electric Heat	49	55	53	59	60	66	27	29	33	22	23	26
	22.5 kW		69	78	72	81	80	89	39	40	44	31	32	35
	30 kW		88	100	92	104	100	112	50	52	55	40	41	44
	45 kW		127	145	131	149	139	157	72	74	78	58	60	62
	60 kW		135	154	139	158	146	166	77	79	82	62	63	66
² Maximum Overcurrent Protection	Unit+ 15 kW	Electric Heat	60	60	60	70	70	70	30	35	35	25	25	30
	22.5 kW		80	90	80	90	90	100	40	45	45	35	35	40
	30 kW	and (1) 0.33 HP	100	110	100	110	110	125	60	60	60	45	45	45
	45 kW	Power Exhaust	150	150	150	175	150	175	80	80	80	60	70	70
	60 kW		150	175	150	175	150	175	80	80	90	70	70	70
³ Minimum Circuit Ampacity	Unit+ 15 kW	Electric Heat	52	58	56	62	63	69	29	31	34	23	25	27
	22.5 kW		72	81	75	84	83	92	40	42	45	32	34	36
	30 kW	and (1) 0.33 HP	91	103	95	107	103	115	51	53	57	41	43	45
	45 kW	Power Exhaust	130	148	134	152	142	160	74	76	79	59	61	64
	60 kW		138	157	142	161	149	169	79	80	84	63	64	67

ELECTRICAL ACCESSORIES

Disconnect	15 kW	54W56	54W56	54W56
	22.5 kW	54W57	54W56	54W56
	30 kW	54W57	54W56	54W56
	45 kW	54W57	54W56	54W56
	60 kW	Not Available	54W56	54W56

NOTE - All units have a minimum Short Circuit Current Rating (SCCR) of 5000 amps.

¹ Extremes of operating range are plus and minus 10% of line voltage.

² HACR type breaker or fuse.

³ Refer to National or Canadian Electrical Code manual to determine wire, fuse and disconnect size requirements.

ELECTRICAL/ELECTRIC HEAT DATA

10 TON

10 TON HIGH EFFICIENCY (R-410A)

KCA120H4

¹ Voltage - 60hz		208/230V - 3 Ph			460V - 3 Ph			575V - 3 Ph		
Compressor 1	Rated Load Amps	13.5			8			5		
	Locked Rotor Amps	109			59			40		
Compressor 2	Rated Load Amps	13.5			8			5		
	Locked Rotor Amps	109			59			40		
Outdoor Fan Motors (2)	Full Load Amps (total)	2.4 (4.8)			1.3 (2.6)			1 (2)		
Power Exhaust (1) 0.33 HP	Full Load Amps	2.4			1.3			1		
Service Outlet 115V GFI (amps)		15			15			20		
Indoor Blower Motor	Horsepower	2	3	5	2	3	5	2	3	5
	Full Load Amps	7.5	10.6	16.7	3.4	4.8	7.6	2.7	3.9	6.1
² Maximum Overcurrent Protection	Unit Only	50	50	60	30	30	35	20	20	25
	With (1) 0.33 HP Power Exhaust	50	60	70	30	30	35	20	20	25
³ Minimum Circuit Ampacity	Unit Only	43	46	53	24	26	29	16	18	20
	With (1) 0.33 HP Power Exhaust	46	49	56	26	27	30	17	19	21

ELECTRIC HEAT DATA

Electric Heat Voltage			208V	240V	208V	240V	208V	240V	480V	480V	480V	600V	600V	600V
² Maximum Overcurrent Protection	Unit+ 15 kW	50	60	60	60	60	70	30	30	35	25	25	30	
	Electric Heat 22.5 kW	70	80	80	90	80	90	40	40	45	35	35	35	
	30 kW	90	100	100	110	100	125	50	60	60	40	45	45	
	45 kW	150	150	150	150	150	175	80	80	80	60	60	70	
³ Minimum Circuit Ampacity	Unit+ 15 kW	49	55	53	59	60	66	27	29	33	22	23	26	
	Electric Heat 22.5 kW	69	78	72	81	80	89	39	40	44	31	32	35	
	30 kW	88	100	92	104	100	112	50	52	55	40	41	44	
	45 kW	127	145	131	149	139	157	72	74	78	58	60	62	
² Maximum Overcurrent Protection	Unit+ 15 kW	60	60	60	70	70	70	30	35	35	25	25	30	
	Electric Heat 22.5 kW	80	90	80	90	90	100	40	45	45	35	35	40	
	and (1) 0.33 HP 30 kW	100	110	100	110	110	125	60	60	60	45	45	45	
	Power Exhaust 45 kW	150	150	150	175	150	175	80	80	80	60	70	70	
³ Minimum Circuit Ampacity	Unit+ 15 kW	52	58	56	62	63	69	29	31	34	23	25	27	
	Electric Heat 22.5 kW	72	81	75	84	83	92	40	42	45	32	34	36	
	and (1) 0.33 HP 30 kW	91	103	95	107	103	115	51	53	57	41	43	45	
	Power Exhaust 45 kW	130	148	134	152	142	160	74	76	79	59	61	64	
Power Exhaust	60 kW	138	157	142	161	149	169	79	80	84	63	64	67	

ELECTRICAL ACCESSORIES

Disconnect	15 kW	54W56			54W56		
	22.5 kW	54W56	54W57		54W56		
	30 kW	54W57			54W56		
	45 kW	54W57			54W56		
	60 kW	Not Available			54W56	N/A	54W56

NOTE - All units have a minimum Short Circuit Current Rating (SCCR) of 5000 amps.

¹ Extremes of operating range are plus and minus 10% of line voltage.

² HACR type breaker or fuse.

³ Refer to National or Canadian Electrical Code manual to determine wire, fuse and disconnect size requirements.

ELECTRICAL/ELECTRIC HEAT DATA

12.5 TON

12.5 TON STANDARD EFFICIENCY (R-410A)

KCB150S4

¹ Voltage - 60hz		208/230V - 3 Ph			460V - 3 Ph			575V - 3 Ph		
Compressor 1	Rated Load Amps	19.6			8.2			6.6		
	Locked Rotor Amps	136			66.1			55.3		
Compressor 2	Rated Load Amps	22.4			10.6			7.7		
	Locked Rotor Amps	149			75.0			54.0		
Outdoor Fan Motors (2)	Full Load Amps (total)	3 (6)			1.5 (3)			1.2 (2.4)		
Power Exhaust (1) 0.33 HP	Full Load Amps	2.4			1.3			1		
Service Outlet 115V GFI (amps)		15			15			20		
Indoor Blower Motor	Horsepower	2	3	5	2	3	5	2	3	5
	Full Load Amps	7.5	10.6	16.7	3.4	4.8	7.6	2.7	3.9	6.1
² Maximum Overcurrent Protection	Unit Only With (1) 0.33 HP Power Exhaust	80	80	90	35	35	40	25	30	30
³ Minimum Circuit Ampacity	Unit Only With (1) 0.33 HP Power Exhaust	62	65	71	28	30	33	22	23	25

ELECTRIC HEAT DATA

Electric Heat Voltage			208V	240V	208V	240V	208V	240V	480V	480V	480V	600V	600V	600V
² Maximum Overcurrent Protection	Unit+ 15 kW	22.5 kW	70	70	80	80	80	80	30	30	35	25	25	30
	Electric Heat 22.5 kW	30 kW	70	80	80	90	80	90	40	40	45	35	35	35
	and (1) 0.33 HP	45 kW	90	100	100	110	100	125	50	60	60	40	45	45
	Power Exhaust	60 kW	150	150	150	150	150	175	80	80	80	60	60	70
³ Minimum Circuit Ampacity	Unit+ 15 kW	22.5 kW	58	58	61	61	67	67	27	29	33	22	23	26
	Electric Heat 22.5 kW	30 kW	69	78	72	81	80	89	39	40	44	31	32	35
	and (1) 0.33 HP	45 kW	88	100	92	104	100	112	50	52	55	40	41	44
	Power Exhaust	60 kW	127	145	131	149	139	157	72	74	78	58	60	62
² Maximum Overcurrent Protection	Unit+ 15 kW	22.5 kW	70	70	80	80	80	80	30	35	35	25	25	30
	Electric Heat 22.5 kW	30 kW	80	90	80	90	90	100	40	45	45	35	35	40
	and (1) 0.33 HP	45 kW	100	110	100	110	110	125	60	60	60	45	45	45
	Power Exhaust	60 kW	150	150	150	175	150	175	80	80	80	60	70	70
³ Minimum Circuit Ampacity	Unit+ 15 kW	22.5 kW	60	60	64	64	70	70	29	31	34	23	25	27
	Electric Heat 22.5 kW	30 kW	72	81	75	84	83	92	40	42	45	32	34	36
	and (1) 0.33 HP	45 kW	91	103	95	107	103	115	51	53	57	41	43	45
	Power Exhaust	60 kW	130	148	134	152	142	160	74	76	79	59	61	64
			138	157	142	161	149	169	79	80	84	63	64	67

ELECTRICAL ACCESSORIES

Disconnect	15 kW	54W56	54W56	54W56
	22.5 kW	54W57	54W56	54W56
	30 kW	54W57	54W56	54W56
	45 kW	Not Available	54W56	54W56
	60 kW	Not Available	54W56	54W56

NOTE - All units have a minimum Short Circuit Current Rating (SCCR) of 5000 amps.

¹ Extremes of operating range are plus and minus 10% of line voltage.

² HACR type breaker or fuse.

³ Refer to National or Canadian Electrical Code manual to determine wire, fuse and disconnect size requirements.

ELECTRIC HEAT CAPACITIES

Volts Input	7.5 kW			15 kW			22.5 kW			30 kW			45 kW			60 kW		
	kW Input	Btuh Output	No. of Stages	kW Input	Btuh Output	No. of Stages	kW Input	Btuh Output	No. of Stages	kW Input	Btuh Output	No. of Stages	kW Input	Btuh Output	No. of Stages	kW Input	Btuh Output	No. of Stages
208	5.6	19,100	1	11.3	38,600	1	16.9	57,700	2	22.5	76,800	2	33.8	115,300	2	45.0	153,600	2
220	6.3	21,500	1	12.6	43,000	1	18.9	64,500	2	25.2	86,000	2	37.8	129,000	2	50.4	172,000	2
230	6.9	23,600	1	13.8	47,100	1	20.7	70,700	2	27.5	93,900	2	41.3	141,000	2	55.1	188,000	2
240	7.5	25,600	1	15.0	51,200	1	22.5	76,800	2	30.0	102,400	2	45.0	153,600	2	60.0	204,800	2
440	6.9	21,500	1	12.6	43,000	1	18.9	64,500	2	25.2	86,000	2	37.8	129,000	2	50.4	172,000	2
460	6.9	23,600	1	13.8	47,100	1	20.7	70,700	2	27.5	93,900	2	41.3	141,000	2	55.1	188,000	2
480	7.5	25,600	1	15.0	51,200	1	22.5	76,800	2	30.0	102,400	2	45.0	153,600	2	60.0	204,800	2
550	6.3	21,500	1	12.6	43,000	1	18.9	64,500	2	25.2	86,000	2	37.8	129,000	2	50.4	172,000	2
575	6.9	23,600	1	13.8	47,100	1	20.7	70,700	2	27.5	93,900	2	41.3	141,000	2	55.1	188,000	2
600	7.5	25,600	1	15.0	51,200	1	22.5	76,800	2	30.0	102,400	2	45.0	153,600	2	60.0	204,800	2

UNIT CLEARANCES

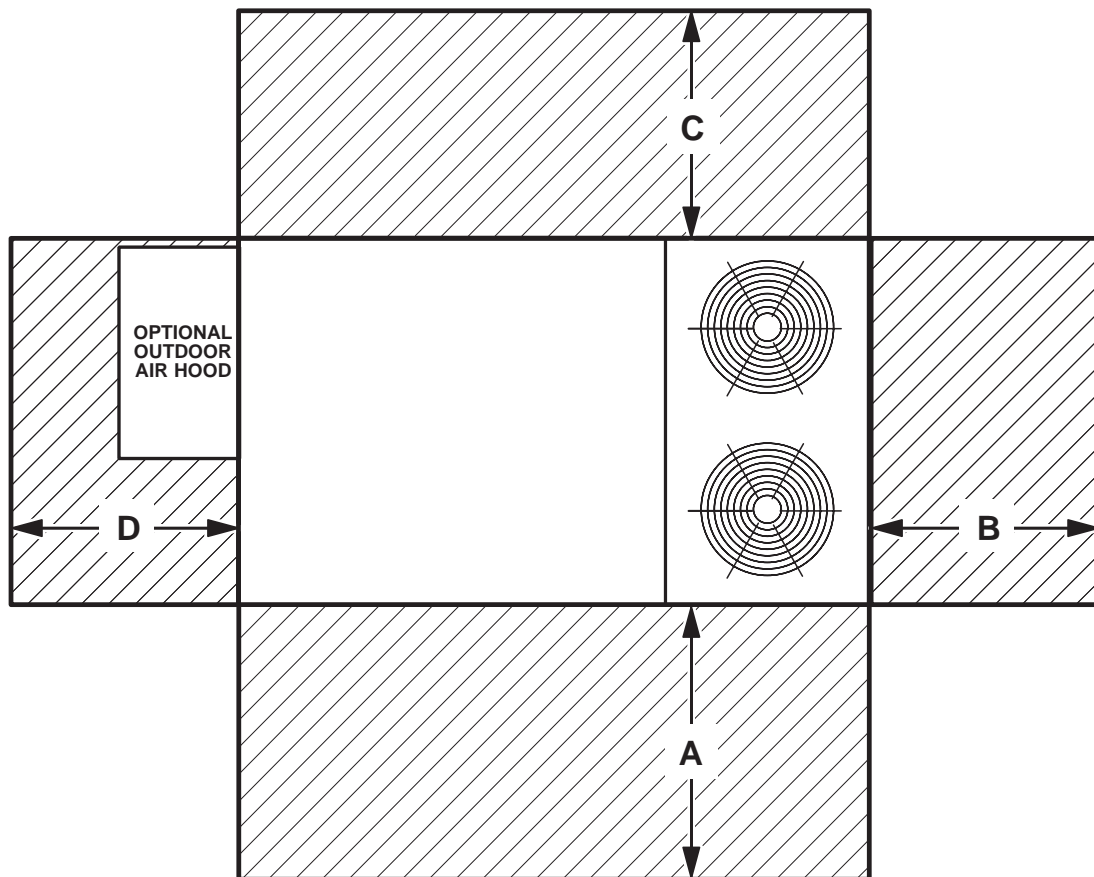

¹ Unit Clearance	A		B		C		D		Top Clearance
	in.	mm	in.	mm	in.	mm	in.	mm	
Service Clearance	60	1524	36	914	36	914	60	1524	Unobstructed
Minimum Operation Clearance	36	914	36	914	36	914	36	914	

NOTE - Entire perimeter of unit base requires support when elevated above the mounting surface.

¹ Service Clearance - Required for removal of serviceable parts.

Minimum Operation Clearance - Required clearance for proper unit operation.

WEIGHT DATA

Model Number	Outdoor Coil	Net		Shipping		Outdoor Coil	Net		Shipping	
		lbs.	kg	lbs.	kg		lbs.	kg	lbs.	kg
092H Base Unit	Eco-Last™	1052	477	1137	516	---	---	---	---	---
092H Max. Unit	Eco-Last™	1209	548	1294	587	---	---	---	---	---
102H Base Unit	Eco-Last™	1059	480	1144	519	---	---	---	---	---
102H Max. Unit	Eco-Last™	1216	552	1301	590	---	---	---	---	---
120H Base Unit	Eco-Last™	1094	496	1179	535	---	---	---	---	---
120H Max. Unit	Eco-Last™	1258	571	1343	609	---	---	---	---	---
092S Base Unit	Eco-Last™	870	395	955	433	Fin/Tube	927	421	1012	459
092S Max. Unit	Eco-Last™	1027	466	1112	504	Fin/Tube	1084	492	1169	531
102S Base Unit	Eco-Last™	890	404	975	442	Fin/Tube	947	430	1032	469
102S Max. Unit	Eco-Last™	1047	475	1132	513	Fin/Tube	1104	501	1189	540
120S Base Unit	Eco-Last™	954	432	1039	471	Fin/Tube	1025	465	1110	504
120S Max. Unit	Eco-Last™	1118	507	1203	545	Fin/Tube	1189	540	1274	578
150S Base Unit	---	---	---	---	---	Fin/Tube	1084	492	1169	531
150S Max. Unit	---	---	---	---	---	Fin/Tube	1234	560	1319	599

NOTE - Max. Unit is the unit with ALL INTERNAL OPTIONS Installed. (Economizer, Standard Static Power Exhaust Fans, Controls, etc.). Does not include accessories EXTERNAL to unit.

OPTIONS / ACCESSORIES

Model Number	Shipping Weight		
	lbs.	kg	
ECONOMIZER / OUTDOOR AIR / EXHAUST			
Economizer			
Economizer Dampers	60	27	
Barometric Relief Dampers (downflow)	8	4	
Barometric Relief Damper Hood (downflow)	25	11	
Outdoor Air Hood (downflow)	23	10	
Outdoor Air Dampers			
Outdoor Air Damper Section - Automatic	51	23	
Outdoor Air Damper Section - Manual	39	18	
Power Exhaust	31	14	
ELECTRIC HEAT			
7.5 kW	50	23	
15 kW	50	23	
22.5 kW	57	26	
30 kW	57	26	
45 kW	59	27	
60 kW	68	31	
DEHUMIDIFICATION SYSTEM			
Dehumidification Option	10	5	
SINGLE ZONE VAV SUPPLY FAN BLOWER OPTION			
Variable Frequency Drive (VFD) and associated components	10	5	
ROOF CURBS			
Hybrid Roof Curbs, Downflow			
8 in. height	60	27	
14 in. height	85	39	
18 in. height	100	45	
24 in. height	125	57	
Adjustable Pitch Curb, Downflow			
14 in. height	191	82	
CEILING DIFFUSERS			
Step-Down	RTD11-95S	118	54
	RTD11-135S	135	61
	RTD11-185S	168	76
Flush	FD11-95S	118	54
	FD11-135S	135	61
	FD11-185S	168	76
Transitions	C1DIFF30B-1	30	14
	C1DIFF31B-1	32	15
	C1DIFF32B-1	36	16
PACKAGING			
LTL Packaging (less than truck load)	105	48	

DIMENSIONS - UNIT

Model No.	CORNER WEIGHTS												CENTER OF GRAVITY											
	AA				BB				CC				DD				EE				FF			
	Base		Max.		Base		Max.		Base		Max.		Base		Max.		Base		Max.		Base		Max.	
	lbs.	kg	lbs.	kg	lbs.	kg	lbs.	kg	lbs.	kg	lbs.	kg	lbs.	kg	lbs.	kg	in.	mm	in.	mm	in.	mm	in.	mm
092S	223	101	309	141	190	86	259	118	206	94	275	124	250	113	341	154	44-1/2	1130	43-1/2	1105	24-1/2	622	25-1/2	648
092H	270	122	310	141	230	104	265	120	249	113	287	130	302	137	348	158	44-1/2	1130	43-1/2	1105	24-1/2	622	25-1/2	648
102S	228	104	316	143	195	88	262	119	211	96	280	127	254	116	347	157	44-1/2	1130	43-1/2	1105	24-1/2	622	25-1/2	648
102H	272	123	312	141	232	105	266	121	251	114	288	131	304	138	350	159	44-1/2	1130	43-1/2	1105	24-1/2	622	25-1/2	648
120S	243	110	331	150	204	93	273	124	220	100	294	133	271	123	369	167	44	1118	43	1092	24-3/4	629	25-3/4	654
120H	283	128	325	148	238	108	274	124	257	116	295	134	316	143	363	165	44	1118	43	1092	24-3/4	629	25-3/4	654
150S	263	119	305	138	222	101	257	117	242	110	280	127	298	135	346	157	44	1118	43	1092	24	610	25	635

Base Unit - The unit with NO OPTIONS.

Max. Unit - The unit with ALL OPTIONS Installed. (Economizer, etc.)

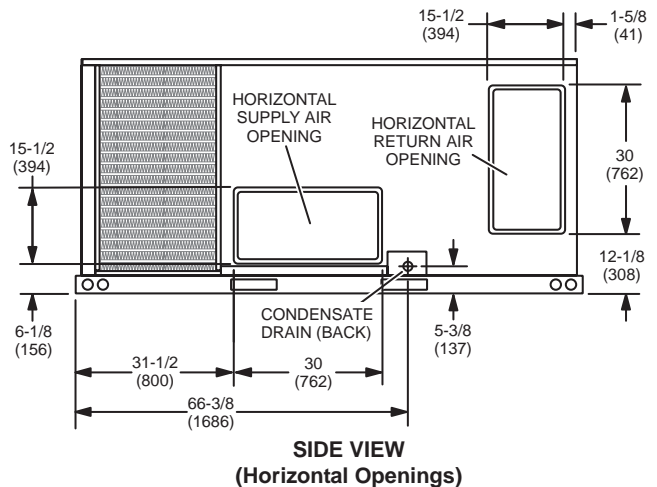
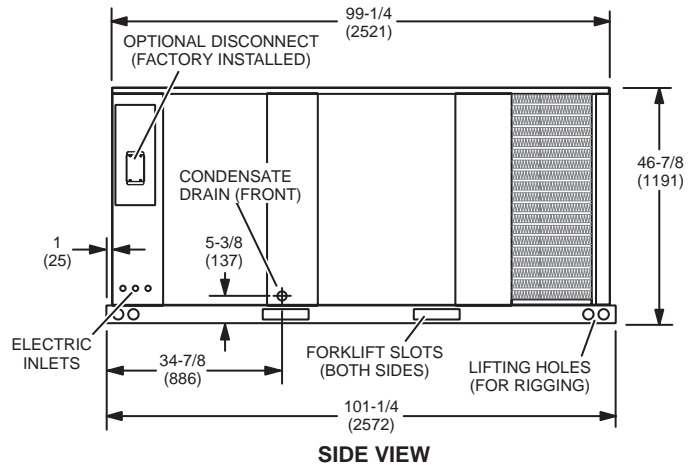
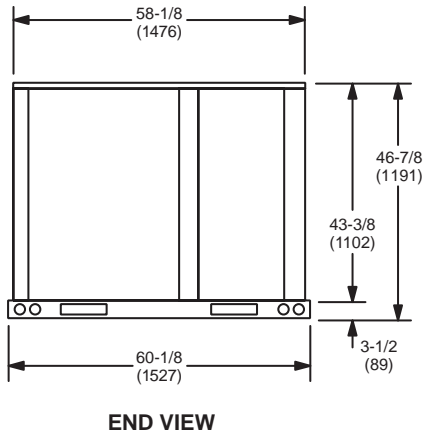
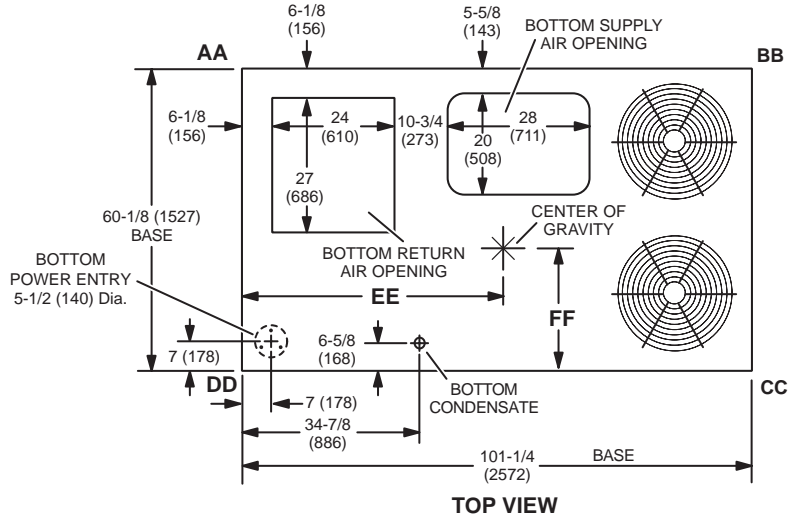

OUTDOOR AIR HOOD DETAIL

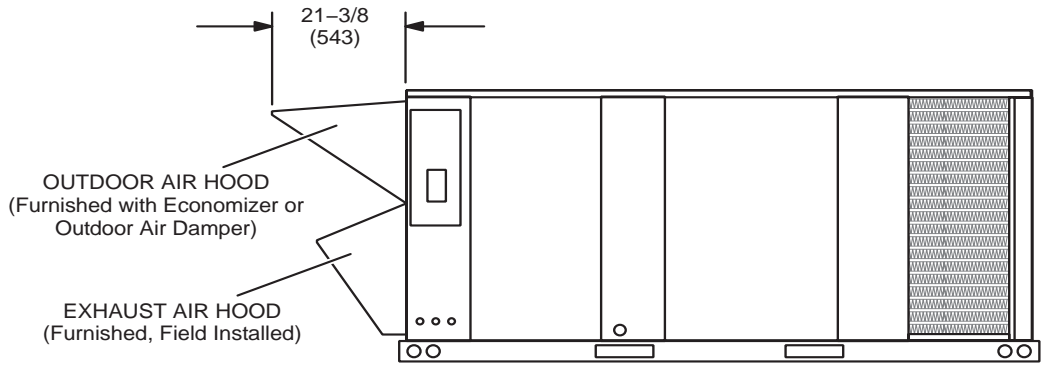

DIMENSIONS - ACCESSORIES

HORIZONTAL ECONOMIZER APPLICATION

(With Furnished Barometric Relief Dampers and Optional Horizontal Discharge Kit - Required)

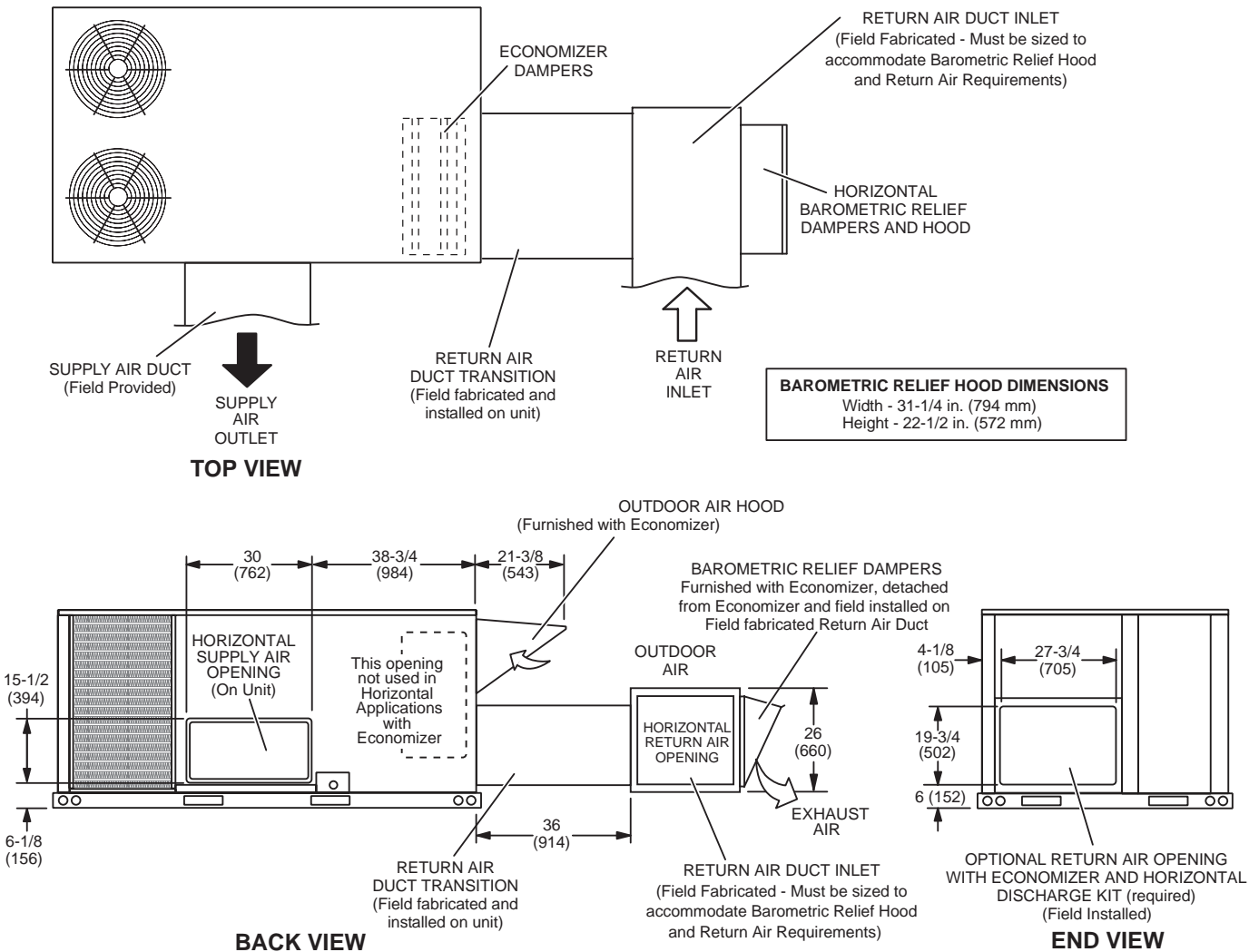

NOTE - Return Air Duct and Transition must be supported.

BAROMETRIC RELIEF DAMPERS (Furnished with Economizer)

(Field installed in horizontal return air duct adjacent to unit)

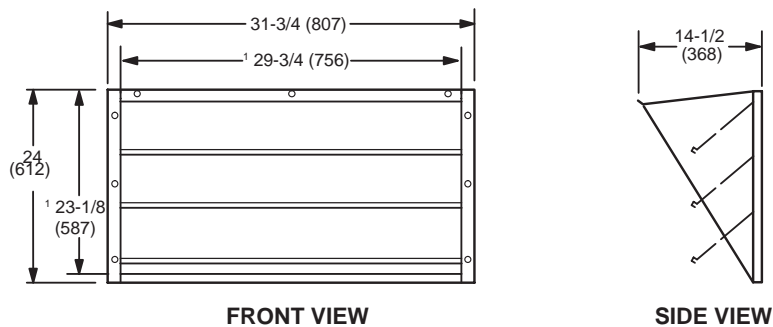

¹ NOTE - Opening size required in return air duct.

DIMENSIONS - ACCESSORIES

HORIZONTAL ECONOMIZER APPLICATION

(with Optional Low Profile Horizontal Barometric Relief Dampers and Horizontal Discharge Kit - Required)

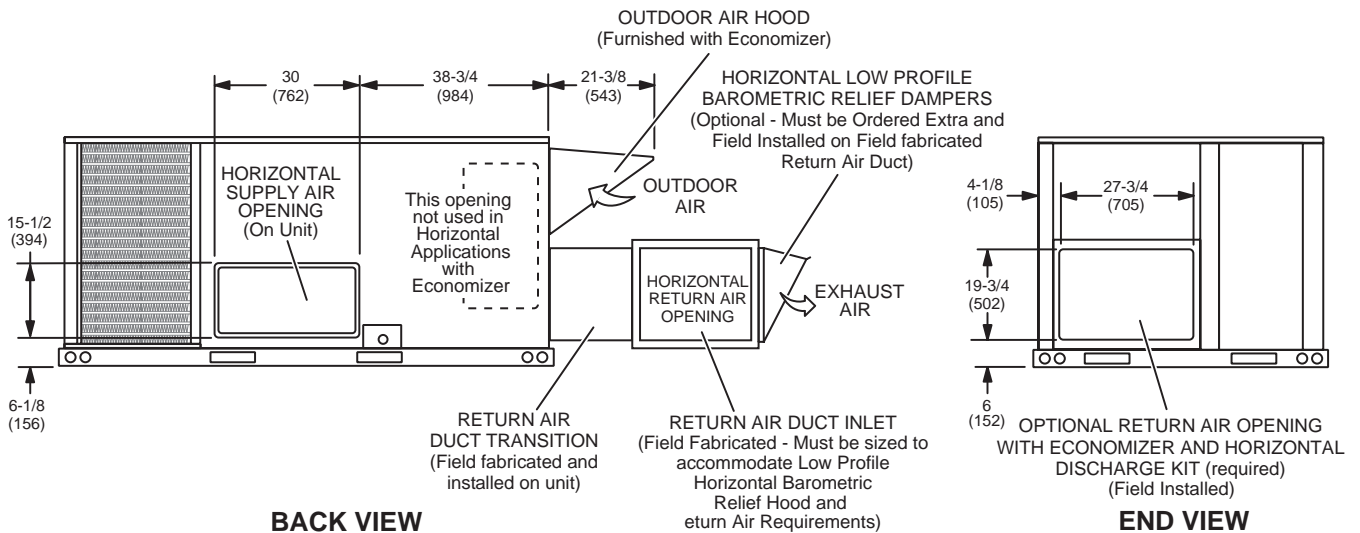
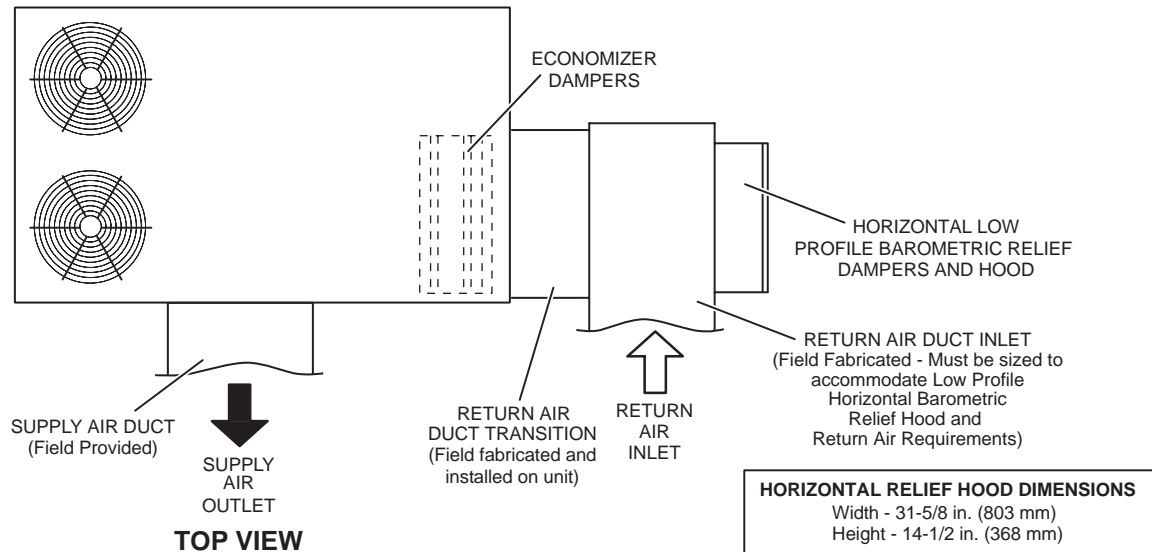

NOTE - Return Air Duct and Transition must be supported.

HORIZONTAL LOW PROFILE BAROMETRIC RELIEF DAMPERS (Field installed in horizontal return air duct adjacent to unit)

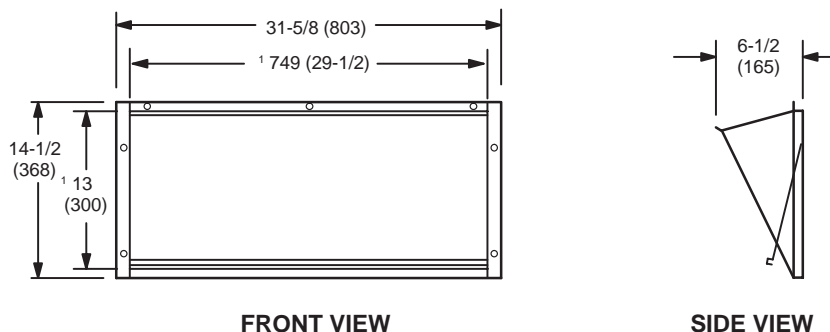

¹ NOTE - Opening size required in return air duct.

DIMENSIONS - ACCESSORIES

HYBRID ROOF CURBS - DOUBLE DUCT OPENING

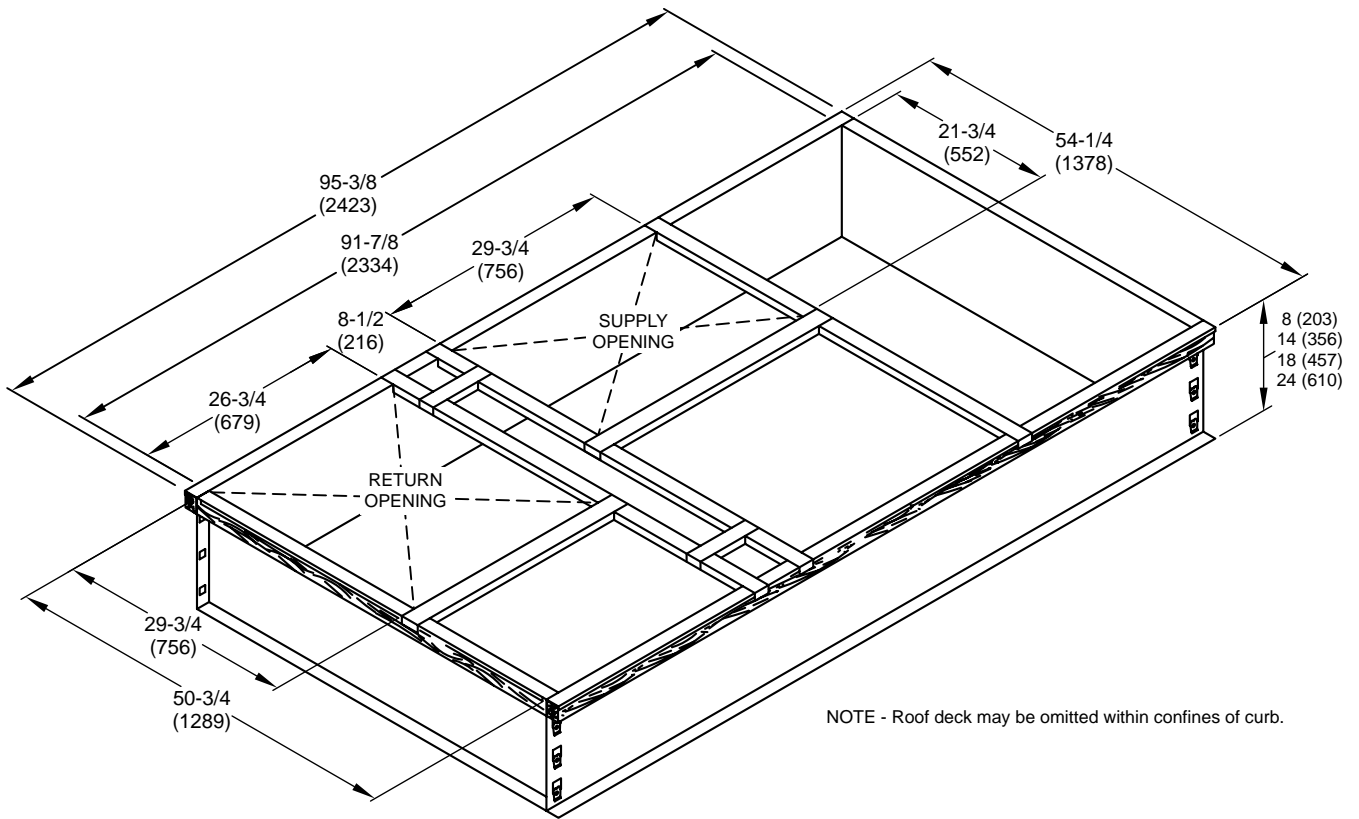

TYPICAL FLASHING DETAIL FOR ROOF CURB

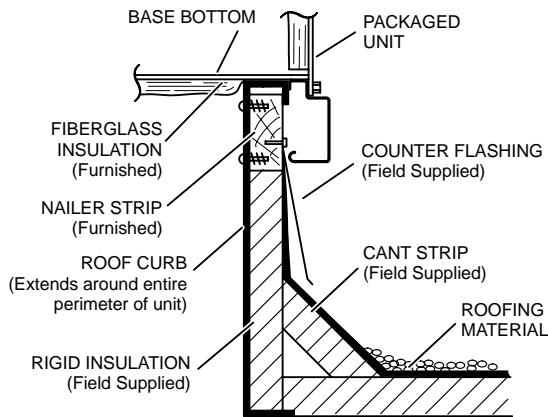

DETAIL ROOF CURB

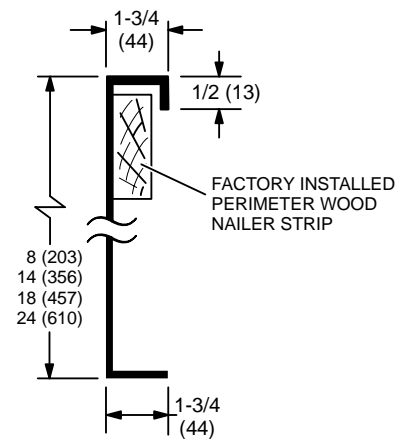

DIMENSIONS - ACCESSORIES

ADJUSTABLE PITCH CURBS - DOUBLE DUCT OPENING

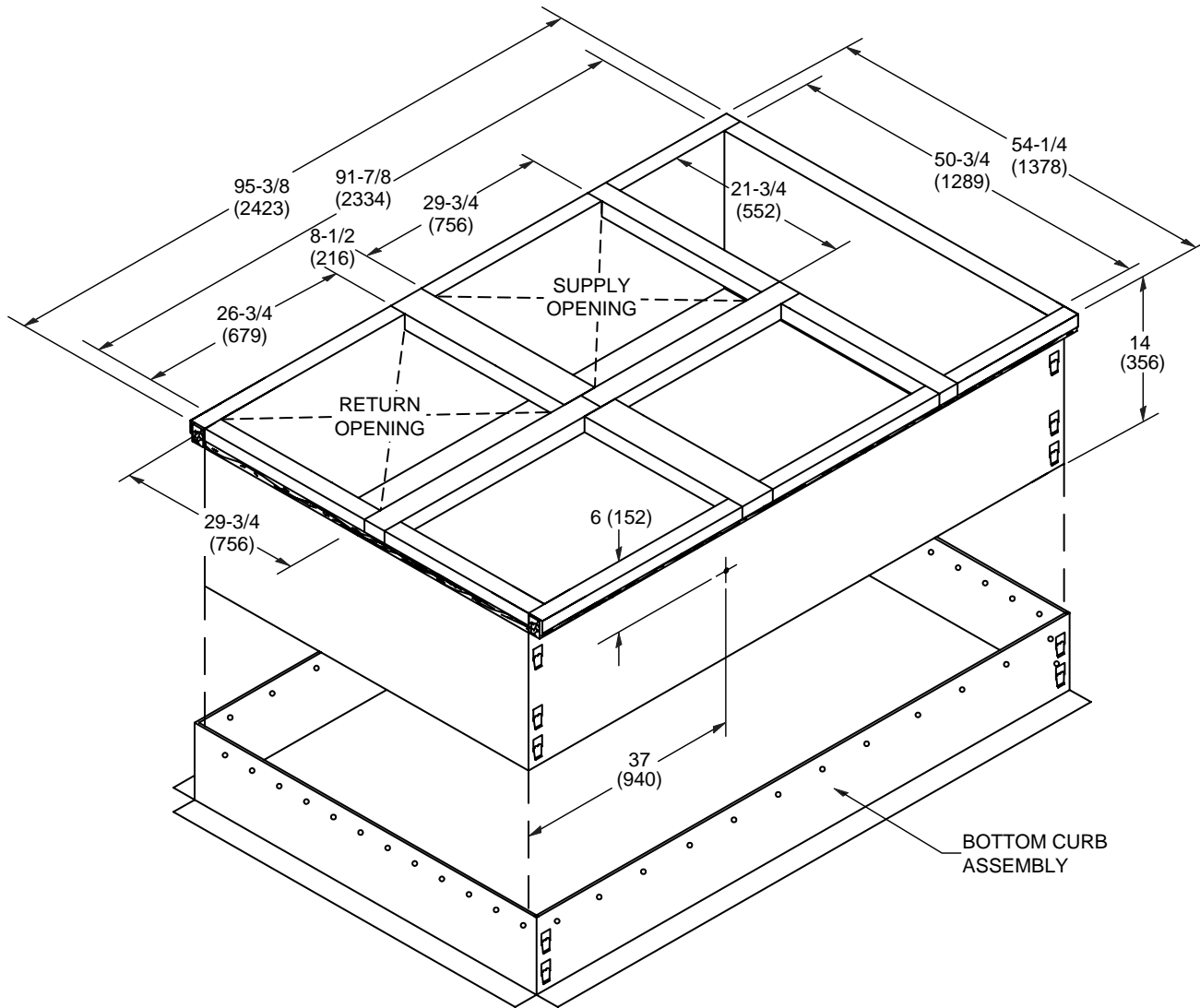

NOTE - Maximum slope pitch is 3/4 in. per 1 foot (19 mm per 305 mm) in any one direction.

TYPICAL FLASHING DETAIL FOR ROOF CURB

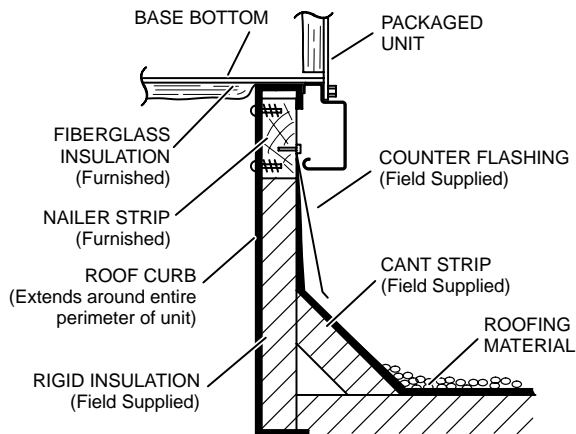

DETAIL ROOF CURB

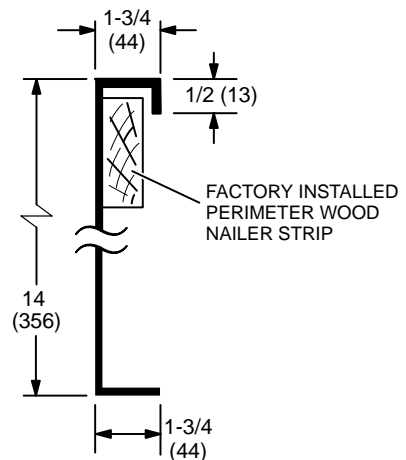

DIMENSIONS - ACCESSORIES

ROOF CURBS WITH SUPPLY & RETURN AIR TRANSITIONS FOR CEILING DIFFUSERS

C1DIFF30B-1 ROUND TRANSITIONS
(for 092 models)

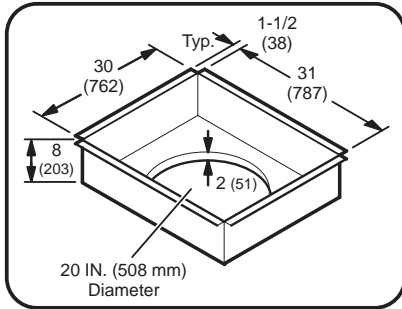

C1DIFF31B-1 & C1DIFF32B-1 RECTANGULAR TRANSITIONS
(for 102 thru 150 models)

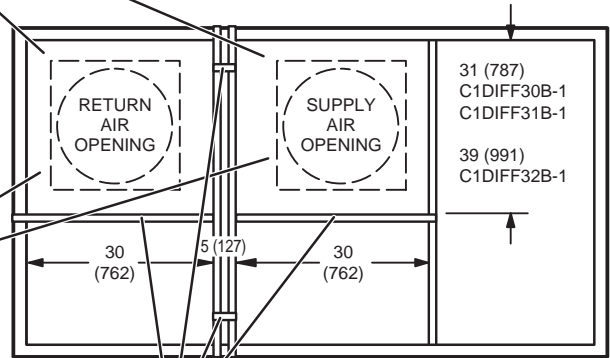
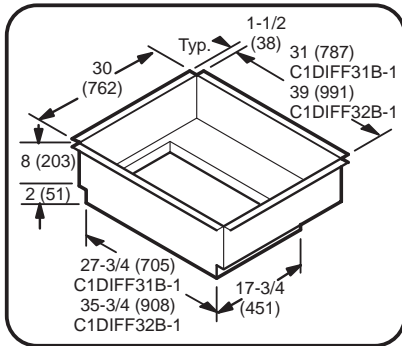

TOP VIEW

NOTE - These four supports are furnished with the transitions to replace supports furnished with curb for proper transition spacing.

DIMENSIONS - ACCESSORIES

COMBINATION CEILING SUPPLY AND RETURN DIFFUSERS

STEP-DOWN CEILING DIFFUSER

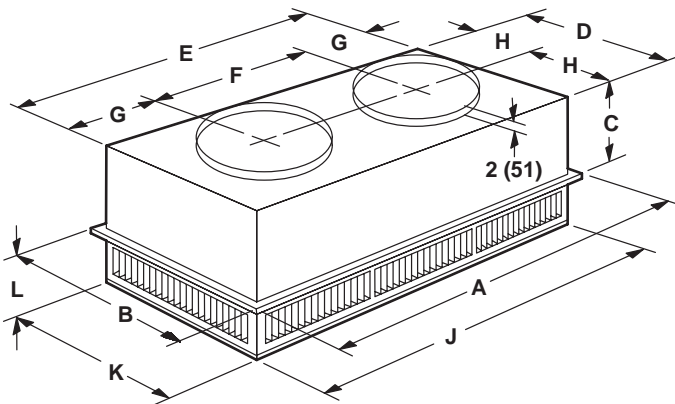

FLUSH CEILING DIFFUSER

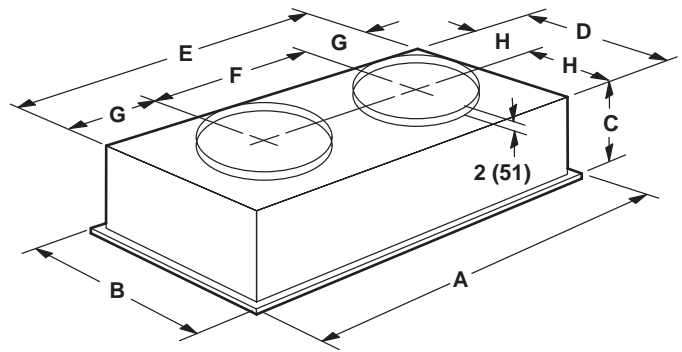

Model Number		RTD11-95S
A	in.	47-5/8
	mm	1159
B	in.	29-5/8
	mm	752
C	in.	14-3/8
	mm	365
D	in.	27-1/2
	mm	699
E	in.	45-1/2
	mm	1158
F	in.	22-1/2
	mm	572
G	in.	11-1/2
	mm	292
H	in.	13-3/4
	mm	349
J	in.	45-1/2
	mm	1156
K	in.	27-1/2
	mm	699
L	in.	8-1/8
	mm	206
Duct Size	in.	20 round
	mm	508 round

Model Number		FD11-95S
A	in.	47-5/8
	mm	1159
B	in.	29-5/8
	mm	752
C	in.	16-5/8
	mm	422
D	in.	27
	mm	686
E	in.	45
	mm	1143
F	in.	22-1/2
	mm	572
G	in.	11-1/4
	mm	286
H	in.	13-1/2
	mm	343
Duct Size	in.	20 round
	mm	508 round

DIMENSIONS - ACCESSORIES

COMBINATION CEILING SUPPLY AND RETURN DIFFUSERS

STEP-DOWN CEILING DIFFUSER

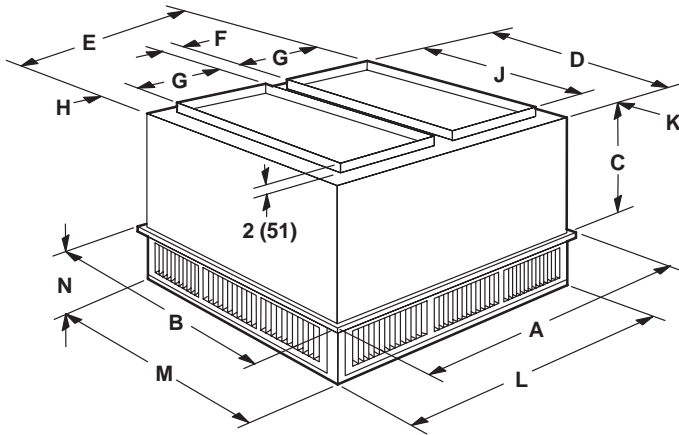

FLUSH CEILING DIFFUSER

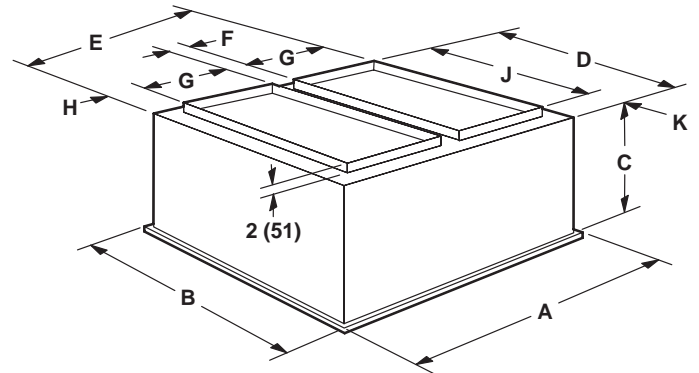

Model Number		RTD11-135S	RTD11-185S
A	in.	47-5/8	47-5/8
	mm	1210	1210
B	in.	35-5/8	47-5/8
	mm	905	1210
C	in.	20-5/8	24-5/8
	mm	524	625
D	in.	33-1/2	45-1/2
	mm	851	1156
E	in.	45-1/2	45-1/2
	mm	1156	1156
F	in.	4-1/2	4-1/2
	mm	114	114
G	in.	18	18
	mm	457	457
H	in.	2-1/2	2-1/2
	mm	64	64
J	in.	28	36
	mm	711	914
K	in.	2-3/4	4-3/4
	mm	70	121
L	in.	45-1/2	45-1/2
	mm	1156	1156
M	in.	33-1/2	45-1/2
	mm	851	1156
N	in.	9-1/8	10-1/8
	mm	232	257
Duct Size	in.	18 x 28	18 x 36
	mm	457 x 711	457 x 914

Model Number		FD11-135S	FD11-185S
A	in.	47-5/8	47-5/8
	mm	1210	1210
B	in.	35-5/8	47-5/8
	mm	905	1210
C	in.	23-1/4	29-1/4
	mm	591	743
D	in.	33	45
	mm	838	1143
E	in.	45	45
	mm	1143	1143
F	in.	4-1/2	4-1/2
	mm	114	114
G	in.	18	18
	mm	457	457
H	in.	2-1/4	2-1/4
	mm	57	57
J	in.	28	36
	mm	711	914
K	in.	2-1/2	4-1/2
	mm	64	114
Duct Size	in.	18 x 28	18 x 36
	mm	457 x 711	457 x 914

REVISIONS

Section	Description
Electrical Data	Updated for KCA092, 102 models.
Specifications	Refrigerant charge updated for KCA092, 102 models.



Visit us at www.allied-commercial.com

For the latest technical information, visit us at www.allied-commercial.com

Contact us at 1-800-448-5872

NOTE - Due to Allied Commercial ongoing commitment to quality, Specifications, Ratings and Dimensions subject to change without notice and without incurring liability. Improper installation, adjustment, alteration, service or maintenance can cause property damage or personal injury. Installation and service must be performed by a qualified installer and servicing agency.