

Catalog Number
Notes
Type

FEATURES & SPECIFICATIONS

INTENDED USE — Provides a minimum of 90 minutes illumination for the rated wattage upon loss of AC power to meet and exceed code required emergency lighting. Ideal for applications requiring attractive LED unit equipment with quick installation and unparalleled performance for mounting heights from 7.5' to 30'.

Certain airborne contaminants can diminish the integrity of acrylic and/or polycarbonate.

[Click here for Acrylic-Polycarbonate Compatibility table for suitable uses.](#)

CONSTRUCTION — The housing is a standard white (black optional) thermoplastic with a compact and low-profile contemporary design. It is SVA flame rated, impact-resistant, scratch-resistant and corrosion proof. The UV-stable resin resists discoloration from natural and man-made light sources. There is a low-profile, integrated and back-lit test switch with an easily visible multi-color LED status indicator. The back-plate contains a universal j-box mounting pattern to facilitate ease of installation on a wide variety of j-boxes and the front housing allows tool-less access for ease of maintenance. **US Patents Pending.**

The lamp heads have a unique track-and-swivel arrangement permitting full range of direction of optical aiming.

OPTICS — The ELM4L features two high-performance LEDs rated at 3.3 watts per lamp head and delivers a total of 640 lumens in a spot pattern (SP640L).

The ELM6L features three high-performance LEDs rated at 5.3 watts per lamp head and delivers a total of 1,100 lumens in a spot pattern (SP1100L).

The typical life of an LED is 10 years. The LED light sources typically never need to be replaced under normal conditions for normal off applications.

CCT: 5000K

ELECTRICAL — Orderable in multiple voltages (see ordering tree for specific voltages.)

Current-limiting charger maximizes battery life and minimizes energy consumption to provide low operating costs. Small battery chargers Certified in the CA Title 20 Appliance Efficiency Database.

Short-circuit protection — current-limiting charger circuitry protects printed circuit board from shorts.

Regulated charge voltage maintains a stable charge voltage over a wide range of line voltages.

Prevents over/undercharging that shortens battery life and reduces capacity. Filtered charger input minimizes charge voltage ripple and extends battery life.

BATTERY: Sealed, maintenance-free nickel-cadmium (ELM4L only) or Lithium Iron Phosphate battery. Optional High-Output (HO option) and Extra High Output (EHO option), LTP battery type only, provides a wide variety of remote capacities and/or extended run-times.

SELF-DIAGNOSTICS and REMOTE TEST (SDRT option):

Automatic 24-hour recharge after a 90-minute discharge.

Advanced electrical design provides constant light output throughout the entire discharge period.

Brownout protection is automatically switched to emergency mode when supply voltage drops below approximately 80 percent nominal of 120, 220, 277 or 347. Other input voltages may vary.

AC/LVD reset allows battery connection before AC power is applied and prevents battery damage from deep discharge.

Self-Diagnostics: Continuously monitors AC functionality. Test switch and remote tester (RTKIT accessory) provide manual activation of 30-second diagnostic testing for on-demand visual inspection. Standard derangement monitoring will indicate disconnected battery, charger failure and displays green flashing indicator light while in emergency mode. Single multi-chromatic LED indicator to display two-state charging, test activation and three-state self-diagnostics.

Self-diagnostic testing: Five minutes every 30 days and 90 minutes annually. Diagnostic evaluation of lamps, AC to DC transfer, battery charging and condition of microprocessor. Automatic test is easily postponed for eight hours by activating manual test switch or use of remote tester (RTKIT accessory).

INSTALLATION — Wall and ceiling mount standard. Blind-mate connector ensures easy installation and safe maintenance. 7/8" entrance provision at top of unit for standard 1/2" conduit entry. Tool-less removal of front cover from back-plate for ease of installation and maintenance.

LISTINGS — UL damp location listed standard and wet location listed when used with the WPVS accessory, all at 50-104°F (10-40°C). Meets or exceeds all applicable requirements for UL 924, NFPA 101 (current Life Safety code), NFPA 70 (NEC), NOM (Norma Oficial Mexicana), California Energy Commission Title 20 section 1605.3 (W)(4), FCC Title 47, Part 15, Subpart B and OSHA. List and labeled to comply with Canadian Standards C22.2 No. 141-10.

WARRANTY — 5-year limited warranty. Complete warranty terms located at:

www.acuitybrands.com/support/customer-support/terms-and-conditions

NOTE: Actual performance may differ as a result of end-user environment and application.

All values are design or typical values, measured under laboratory conditions at 25 °C.

Specifications subject to change without notice.

† Small Battery Chargers Certified in the CA Title 20 Appliance Efficiency Database.

Contemporary Commercial LED Emergency Light



ELM4L
640 Lumens

ELM6L
1100 Lumens

**LITHIUM IRON PHOSPHATE
NICKEL CADMIUM**



MOUNTING

All dimensions are inches (centimeters) unless otherwise indicated.

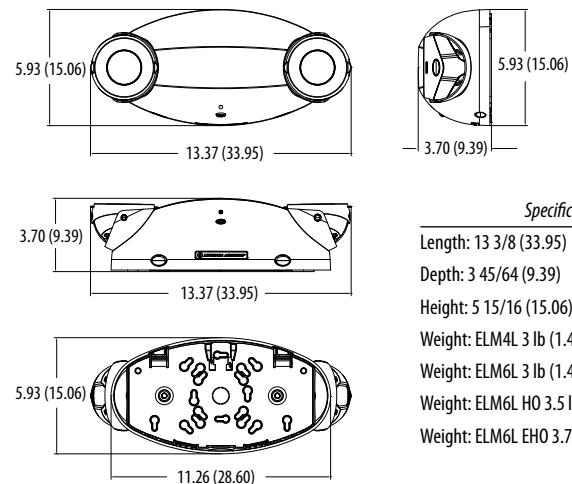

Specifications

Length: 13 3/8 (33.95)

Depth: 3 45/64 (9.39)

Height: 5 15/16 (15.06)

Weight: ELM4L 3 lb (1.4kg)

Weight: ELM6L 3 lb (1.4kg)

Weight: ELM6L HO 3.5 lbs (1.59 kg)

Weight: ELM6L EHO 3.75 lbs (1.7 kg)



ELM4L-ELM6L Quantum® LED Contemporary Commercial Emergency Light



Looking for Contractor Select readily available configurations? Click here to visit Contractor Select™ spec sheet or go to www.contractorselect.com

NICKEL CADMIUM BATTERY MODELS

ORDERING INFORMATION For shortest lead times, configure product using **bolded options**.

Example: ELM4L

Series	Lamp Type	Housing Color	Voltage	Battery Type	Automatic Testing	Options
ELM4L ¹	640 lumens, adjustable optics (blank) SP640L 640 lumen, 6.6 watt, Spot Pattern, two lamp	(blank) White B Black	(blank) 120-277 VAC, 50/60Hz UVOLT 120 - 347 VAC, 50/60Hz	(blank) Nicad	(blank) None SDRT Self Diagnostics, Remote Test ²	(blank) none WPVS Wet protective vandal shield ³ USPOM Assembled in the US

Notes

- Does not support remote loads.
- SDRT only available with UVOLT
- Must be ordered when using for wet location applications.. WPVS breaks out and ships separately and color will match (ex: WPVS LRG B). Decreases delivered lumens up to 20%. See spec sheet [WPVS](#) for more information.

LITHIUM IRON PHOSPHATE BATTERY MODELS

ORDERING INFORMATION For shortest lead times, configure product using **bolded options**.

Example: ELM6L UVOLT LTP SDRT

Series ¹	Lamp Type	Housing Color	Voltage	Battery Type	Automatic Testing	Options
ELM4L	640 lumens, adjustable optics (blank) SP640L 640 lumen, 6.6 watt, Spot Pattern, two lamp	(blank) White B Black	UVOLT 120 - 347 VAC, 50/60Hz	LTP Lithium Iron Phosphate	(blank) none ² SDRT Self-diagnostics, remote test ³	LLH Less lamp heads ⁴
ELM6L	1100 lumens, adjustable optics (blank) SP1100L 1100 lumen, 10.6 watt, Spot Pattern, two lamp					HO High-output battery EHO Extra High-output battery WPVS Wet protective vandal shield ⁵ USPOM Assembled in the US PM Pendant mount ⁶

Notes

- Extended run-time or remote capacity is standard. New ELMRE style remotes are compatible with both SDRT and non-SDRT versions (see page 3).
- Only available with ELM4L.
- SDRT not compatible to run previous generation ELA style remotes (see page 3).
- ELM4L with LLH (less lamp heads) not available with SDRT. Order ELM6L with LLH if SDRT is required.
- Must be ordered when using for wet location applications. WPVS breaks out and ships separately and color will match (ex: WPVS LRG B). Decreases delivered lumens up to 20%. See spec sheet [WPVS](#) for more information.
- Pendant mount option will include a 12" long 3/8-16 UNC threaded rod and hardware. Not available with any other lengths. Only available with ELM6L series, not available with ELM4L series.

Other Accessories: Order as separate catalog number.

WPVS LRG W	Wet protective vandal shield, white (must be used for wet location applications)
WPVS LRG B	Wet protective vandal shield, black (must be used for wet location applications)
ELA WG1	Wireguard, 13 3/4"H x 15 1/4"W x 6"D (see spec sheet ELA-WG).
RTKIT	Remote test kit, up to 40' away (includes goggles, laser and battery)



ELM4L-ELM6L mounted inside the WPVS

ELM4L-ELM6L Quantum® LED Contemporary Commercial Emergency Light

SPACING GUIDELINES

*Note: To see complete photometric report or download the .ies file for this product, visit Lithonia Lighting ELM4L and ELM6L home page.

Maximum Spacing Guidelines — ELM4L ¹						
Mounting Height	Illumination Level	Single Luminaire		Multiple Luminaire		Application Notes
		3' Path of Egress	6' Path of Egress	3' Path of Egress	6' Path of Egress	
7.5'	1FC Avg ¹	62'	58'	67'	60'	100' Corridor, 8' wide, and 12' high with 80/50/20 reflectances
10'	1FC Avg ¹	62'	58'	67'	60'	
7.5'	1FC Avg ¹	52'	40'	66'	58'	Retail open area: 200' X 15' X 30' with 80/50/20 reflectances
10'	1FC Avg ¹	52'	48'	64'	60'	
12'	1FC Avg ¹	52'	48'	62'	59'	
16'	1FC Avg ¹	52'	44'	61'	58'	
20'	1FC Avg ¹	44'	42'	60'	58'	
24'	1FC Avg ¹	34'	34'	42'	58'	

Maximum Spacing Guidelines — ELM6L ¹						
Mounting Height	Illumination Level	Single Luminaire		Multiple Luminaire		Application Notes
		3' Path of Egress	6' Path of Egress	3' Path of Egress	6' Path of Egress	
7.5'	1FC Avg ¹	76'	74'	98'	90'	100' Corridor, 8' wide, and 12' high with 80/50/20 reflectances
10'	1FC Avg ¹	76'	74'	98'	88'	
7.5'	1FC Avg ¹	60'	48'	77'	68'	Retail open area: 200' X 15' X 30' with 80/50/20 reflectances
10'	1FC Avg ¹	78'	56'	85'	82'	
12'	1FC Avg ¹	68'	66'	77'	74'	
16'	1FC Avg ¹	72'	68'	72'	74'	
20'	1FC Avg ¹	66'	64'	70'	68'	
24'	1FC Avg ¹	66'	56'	65'	62'	

Notes:

- Also meets the additional illumination requirements of NFPA 101: 1FC minimum and max/min ratio of 40:1.

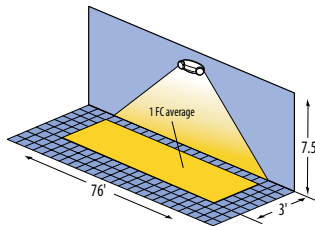

Example of single ELM4L illuminating a 3' path of egress

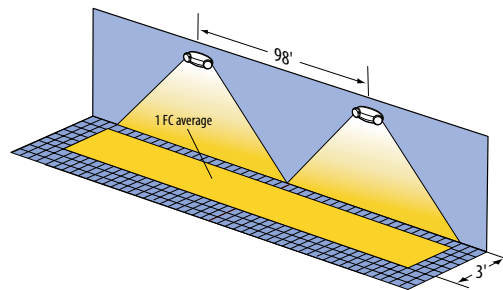

Example of multiple ELM6L units illuminating a 3' path of egress

REMOTES

BATTERY CAPACITY AND LOADING - INDOOR/ DAMP LOCATION REMOTES						Outdoor/ Wet Location Remotes
Battery Option (LTP Only)	Battery Voltage	Total Capacity 90 Minutes	LP220L (1.2 Watts each) Maximum # Remote Lamps ¹	SP640L (3.3 Watts each) Maximum # Remote Lamps ¹	SP1100L (5.3 Watts each) Maximum # Remote Lamps ¹	ELA QWP (1.5 Watts each) Maximum # Remote Lamps ^{1,2}
ELM4L LTP	9.6V	11 watts	3	1	0	2
ELM4L LTP HO	9.6V	22 watts	12	4	2	10
ELM4L LTP EHO	12.6V	32 watts	21	7	6	N/A
ELM6L LTP	9.6V	11 watts	0	0	0	N/A
ELM6L LTP HO	9.6V	22 watts	9	3	2	N/A
ELM6L LTP EHO	12.6V	32 watts	17	6	4	N/A
ELM6L LLH LTP	9.6V	11 watts	9	3	2	N/A
ELM6L LLH LTP HO	9.6V	22 watts	18	6	4	N/A
ELM6L LLH LTP EHO	12.6V	32 watts	26	9	6	N/A

Notes

- These are in addition to the lamp heads on the product.
- Not compatible with SDRT. For ELA QWP ordering information, please see spec sheet [ELA-Q-LED](#).
For wet location applications, must order ELMRE remote with WPVS accessory when ordering ELM6L UVOLT LTP SDRT.

ELMRE Compatible Remotes^{1,2}

LTP Compatible Remote Accessories: Order as separate catalog number.	
ELMRE LP220L SGL	Single LED Indoor remote head, white.
ELMRE LP220L T	Twin LED Indoor remote heads, white.
ELMRE SP640L SGL	Single LED Indoor remote head, white.
ELMRE SP640L T	Twin LED Indoor remote heads, white.
ELMRE SP1100L SGL	Single LED Indoor remote head, white.
ELMRE SP1100L T	Twin LED Indoor remote heads, white.

Notes

- Compatible with SDRT and non-SDRT versions.
- Order the WPVS accessory for wet location listing and vandal protection.



ELA QWP



ELA T QWP



ELMRE LP220L SGL



ELMRE LP220L SGL T



ELMRE SP640L SGL



ELMRE SP640L T



ELMRE SP1100L SGL



ELMRE SP1100L T



ELMRE LP220L T with WPVS SML W (order WPVS separately)

ELM4L-ELM6L Quantum® LED Contemporary Commercial Emergency Light

SPECIFICATIONS

ELECTRICAL			
Primary Circuit			
Type	Volts	Input amps	Watts
Nicad	120	0.032	3.15
	347	0.036	3.15
Lithium Iron Phosphate (SDRT)	120	0.028	2.78
	347	0.033	2.78
Lithium Iron Phosphate (HO option)	120	0.046	4.77
	347	0.046	4.77
Lithium Iron Phosphate (EHO option)	120	0.052	5.95
	347	0.045	5.95

BATTERY CAPACITY FOR EXTENDED RUN-TIMES				
Battery Option	Total Capacity 2 hours	Remote Capacity 2 hours*	Total Capacity 4 hours	Remote Capacity 4 hours*
ELM4L - LTP	8.25 watts	NA	NA	NA
ELM4L - HO	16.5 watts	9.9 watts	8.25 watts	NA
ELM4L EHO	24 watts	17.4 watts	12 watts	5.4 watts
ELM6L - LTP	8.25 watts**	8.25 watts**	NA	NA
ELM6L HO	16.5 watts	5.9 watts	8.25 watts**	8.25 watts**
ELM6L EHO	24 watts	13.4 watts	12 watts	12 watts**

* Remote capacity left after using standard lamps shipped mounted on luminaire. ELM4L standard high performance LED lamp heads are rated at 3.3 watts each, delivering a total of 640 lumens. ELM6L standard high performance LED lamp heads are rated at 5.3 watts each, delivering a total of 1,100 lumens. These lamps are different in both wattage and performance from the LT24 compatible remotes.

** LLH option only

BATTERY			
Nicad (6V)			
Typical Shelf life ¹	Typical life ¹	Maintenance ²	Temperature range ^{3,4}
3 years	7-9 years	none	50-104°F (10-40°C)
Lithium Iron Phosphate (standard and HO option) (9.6V)			
Typical Shelf life ¹	Typical life ¹	Maintenance ²	Temperature range ^{3,4}
1 year	7-9 years	none	50-104°F (10-40°C)
Lithium Iron Phosphate (EHO option) (12.8V)			
Typical Shelf life ¹	Typical life ¹	Maintenance ²	Temperature range ^{3,4}
1 year	7-9 years	none	50-104°F (10-40°C)

Notes

- 1 At 77°F ambient temperature, charge/discharge cycles and prolonged full discharge may reduce useful life.
- 2 All life safety equipment, including emergency lighting for path of egress must be tested in accordance with all National Fire Protection Association (NFPA) and local codes. Failure to perform the required testing could jeopardize the safety of occupants and will void all warranties.
- 3 Optimum ambient temperature range where unit will provide capacity for 90 minutes. Higher and lower temperatures affect life and capacity.
- 4 Battery life is negatively impacted by many variables including temperature, charging rates, number of cycles and deep discharges due to long periods of time without AC power.