

Installation/Operating Instructions

K671GAD / K676GADDR

Deadbreak Grounding Device and Insulated Cap with Test Point

*Contents: 28KV GADDR = K671GAD Grounding Device, K676GADDR Insulating Cap, (2) Lubes and Installation Instructions.
 K671GAD = K671GAD Grounding Device, Lube and Installation Instructions.
 K676GADDR = K676GADDR Insulating Cap, Lube and Installation Instructions.*

DANGER

All apparatus must be de-energized during installation or removal of part(s).

All apparatus must be installed and operated in accordance with individual user, local, and national work rules. These instructions do not attempt to provide for every possible contingency.

Do not touch or move other energized products in the work area.

This product should be installed only by competent personnel trained in good safety practices involving high voltage electrical equipment. These instructions are not intended as a substitute for adequate training or experience in such safety practices.

Excess distortion of the assembled product may result in its failure.

Failure to follow these instructions will result in damage to the product and serious or fatal injury.

If this product is supplied with a protective shipping cover(s), remove this shipping cover(s) and replace with the appropriate HV insulated cap(s) or connector(s) before submerging or energizing the circuit.

FOR MORE INFORMATION ON PARTS, INSTALLATION RATINGS AND COMPATIBILITY, CALL THE NEAREST ELASTIMOLD-® OFFICE.

Limited Warranty:

1. T&B warrants that its products will be free from defects in materials or workmanship for a period of two (2) years, except for tools which are warranted separately (see warranty accompanying those products). Fisher Pierce® products and Elastimold® Reclosers are warranted for three years; and Joslyn™ VBT and VBU capacitor switches are warranted for four years or 40,000 operations whichever occurs first. Upon prompt notification of a warranted defect, T&B will, at its option, repair or replace the defective product.
2. In no event shall T&B be liable for any consequential, indirect or special damages, nor will T&B be liable for transportation, labor, or other charges arising out of the removal or reinstallation of its products. Liability for breach of warranty is limited to the cost of repair or replacement of the warranted product only.
3. Misuse, misapplication or modification of T&B products immediately voids all warranties.

THE WARRANTIES AND REMEDIES CONTAINED HEREIN ARE EXCLUSIVE AND ARE IN LIEU OF ALL OTHER WARRANTIES AND REMEDIES, INCLUDING BUT NOT LIMITED TO ANY IMPLIED WARRANTIES OF MERCHANTABILITY AND FITNESS FOR A PARTICULAR PURPOSE, WHICH ARE SPECIFICALLY DISCLAIMED.

IMPORTANT

1. Check contents of package to ensure they are complete and undamaged.
2. Check all components to ensure proper fit with cable and/or mating products.
3. Read entire installation instructions before starting.
4. Have all required tools at hand and maintain cleanliness throughout the procedure.

K671GAD

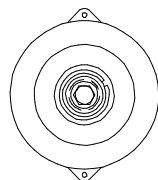

Ground Clamp
Connection Rod

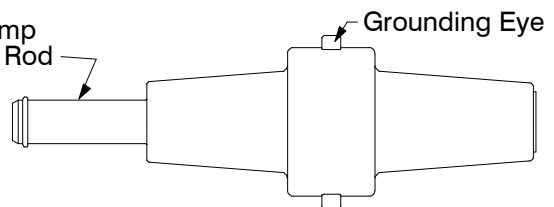

K671GADDR

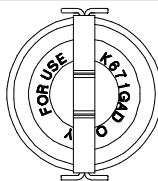

Assembly /
Disassembly Bail

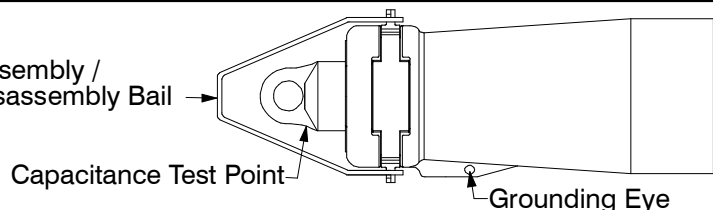

STEP 1 (Installing the K671GAD Grounding Connector)

- A.) Install the 600Amp elbow onto the apparatus bushing following the instructions supplied with the elbow. **DO NOT INSTALL THE INSULATING PLUG OR CAP.**
- B.) Clean and lubricate the K671GAD Grounding Connector interface and 600Amp elbow interface with lubricant supplied. **DO NOT SUBSTITUTE.** Other lubricant may be harmful to the product or its mating product(s).
- C.) Insert K671GAD Grounding Connector into the elbow and rotate clockwise to engage the stud.

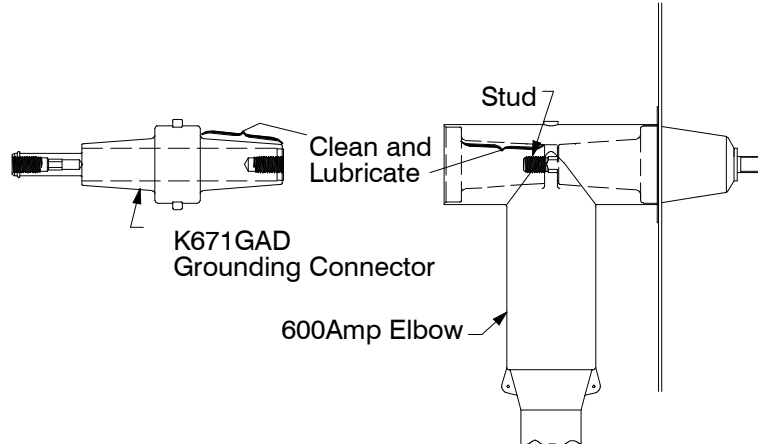

- D.) Insert the 600ATM assembly tool into the K671GAD Grounding Connector and using a torque wrench continue rotating clockwise. When the K671GAD Grounding Connector stops rotating, tighten to 55/60 foot/pounds torque. Remove the 600ATM tool.

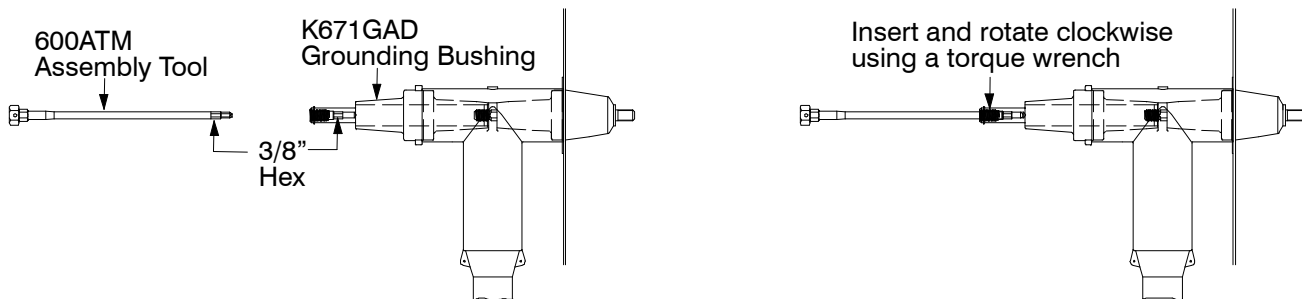

- E.) Using a separate copper wire (No 14AWG/2.55mm) or equivalent, insert one end through the grounding eye on the K671GAD Grounding Connector. Twist tightly taking care not to damage the eye. The other end of the wire must be attached to the system ground.

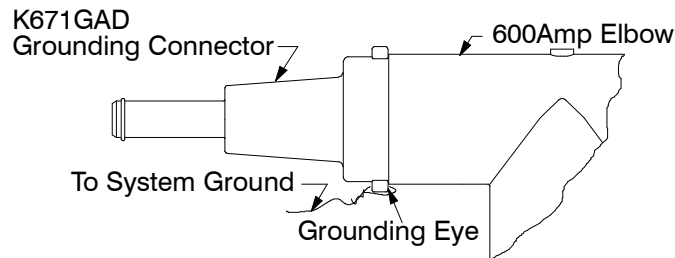

STEP 2 (Installing the K676GADDR Insulating Cap)

- A.) Insert a length of No. 14 AWG (2.5mm²) copper wire (or equivalent) through the grounding eye of the insulated cap. Make a small loop and twist tightly, taking care not to damage the grounding eye. Connect free end of grounding wire to the system ground. Length of grounding wire should be sufficient for the distance from the grounding point to the grounding eye of the insulated cap plus enough to wrap around the insulated cap 10 times (90°) during assembly (see Step C).

Note: 2 hotsticks will be needed for Steps 2 & 3)

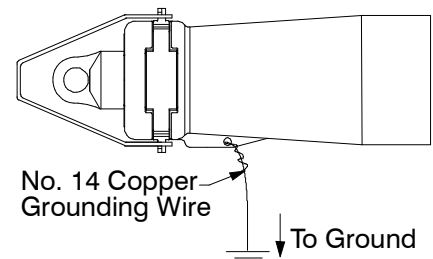

B.) Clean and lubricate the K676GADDR insulating cap and the K671GAD interface with lubricant supplied. DO NOT SUBSTITUTE. Other lubricant may be harmful to the product or its mating product(s).

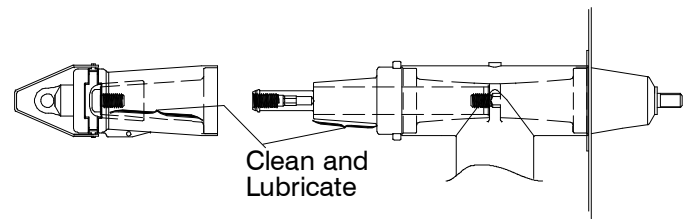

C.) During installation of the insulated cap, the grounding wire will be wrapped around the body of the insulated cap. A second hotstick will be required to control the tension and position of the grounding wire. The wire should be wrapped loosely about the center of the insulated cap.

Attach the first hotstick tool to the insulated cap assembly/disassembly bail and push receptacle onto bushing interface as far as it will go. With the second hotstick, engage grounding wire and establish slight tension (see illustration). With first hotstick, while pushing against the bushing interface, rotate clockwise until the threads between bushing and insulated cap engage; continue turning without pushing until resistance is felt. **DO NOT OVERTIGHTEN.** Remove 2nd hotstick.

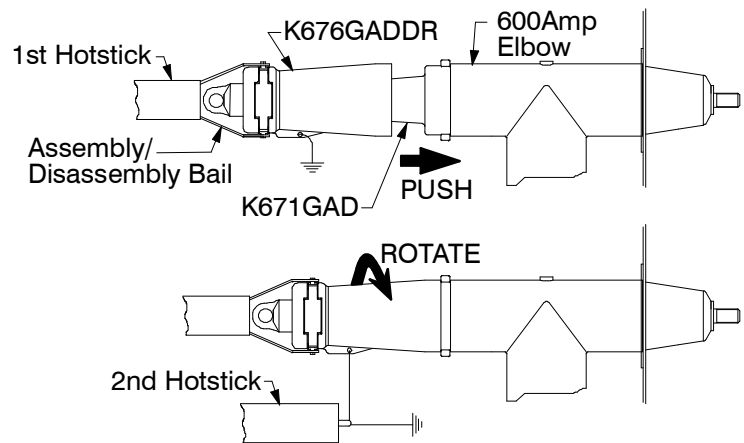

STEP 3

Removing The Insulated Cap

WARNING: DO NOT DISCONNECT WHILE ENERGIZED.

Conduct Voltage Test as described below to ensure system is de-energized.

A.) Voltage Test

The ELASTIMOLD® K676GADDR insulated cap is equipped with an integral capacitance test point that can be used to establish whether or not the circuit is energized. When using the test point, complete the following steps:

1. Remove the voltage detection point cap with a hotstick. When removing cap, PEEL OFF AT AN ANGLE rather than pulling directly in line with the test point assembly.
2. **WARNING: THE VOLTAGE TEST POINT IS A CAPACITANCE DEVICE, IT IS NOT DIRECTLY CONNECTED TO THE CONDUCTOR.** Do not use conventional voltage measuring equipment. Follow the manufacturer's directions for the meter that is used. Test with a suitable sensing device, made for use with separable connectors manufactured with capacitive test points, to determine if cable is energized. Contamination, moisture, dirt, etc. around the test point or use of the wrong measuring equipment can provide a false "no voltage" indication on an energized elbow. To prevent serious or fatal injury treat the elbow as energized until the "no voltage" test point indication is confirmed by other means.
3. After voltage detection has been made, clean and lubricate the inside surface of the cap with silicone grease and replace it on the test point.

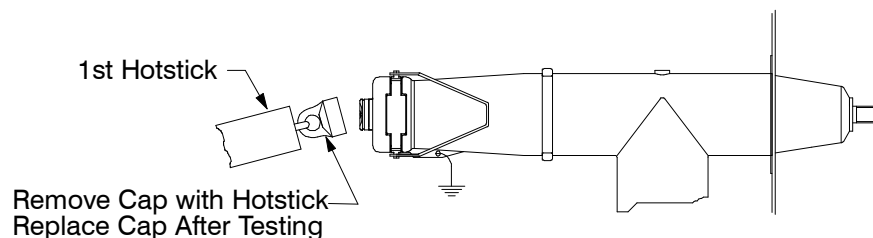

B.) After the circuit is known to be de-energized securely fasten a hotstick to the assembly/disassembly bail. Without exerting any pulling force, rotate the receptacle **counter-clockwise** eight or nine turns. With a second hotstick tool, control the unwound ground wire so that the wire will not interfere with adjacent devices or entangle itself with the first hot stick tool. Then exert pulling force to remove the insulated cap from the bushing interface.

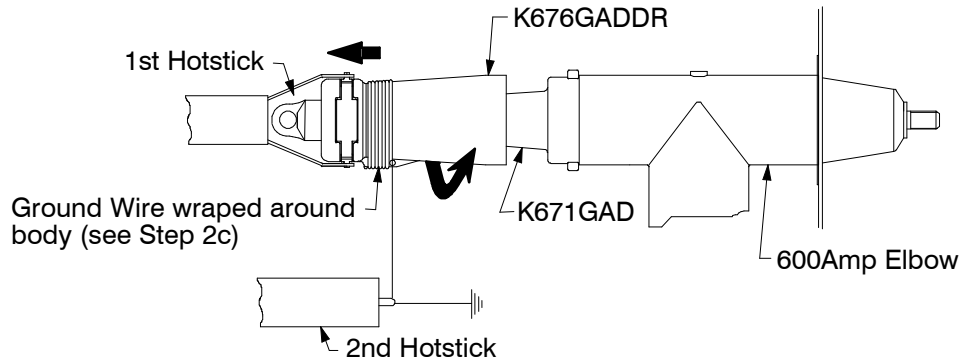

STEP 4 (Install Ground Clamp)

The K671GAD has a copper bus extending out from the interface end so that a hot line grounding clamp can be attached. **FOR THIS STEP FOLLOW YOUR UTILITY'S OPERATING PROCEDURE.**

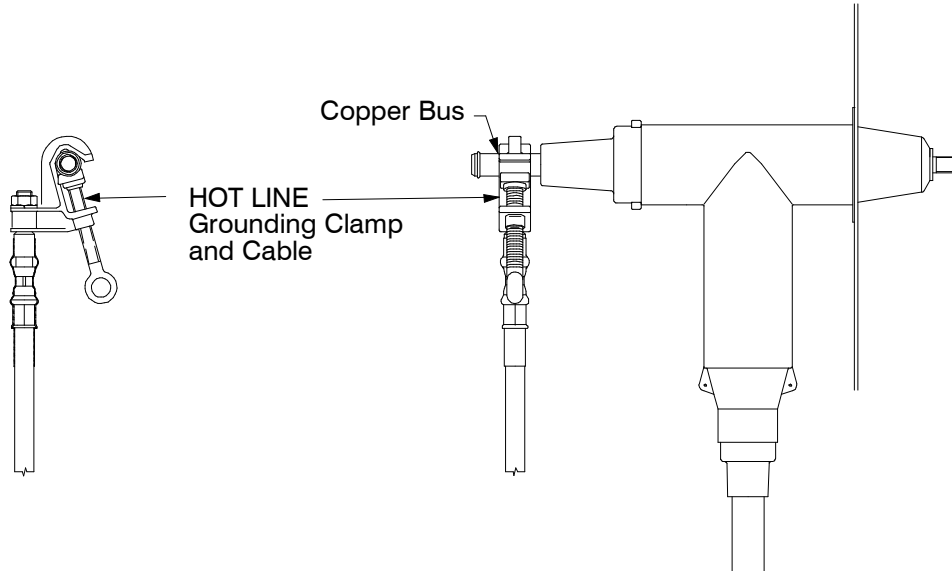

STEP 5 (Remove Ground Clamp and Install Cap)

When Repairs have been completed, remove the hot line grounding clamp. Install the K676GADDR following Step 2.

THOMAS & BETTS CORP. PROPRIETARY AND CONFIDENTIAL

BY ACCEPTANCE OF THIS DOCUMENT YOU AGREE THAT ALL RIGHTS TO THE DRAWINGS AND INFORMATION CONTAINED IN IT, AS WELL AS THE SUBJECT MATTER AND ALL PROPRIETARY AND NOVEL FEATURES DISCLOSED, ARE OWNED BY THOMAS & BETTS CORP AND THAT DEVICES EMBODYING SUCH FEATURES OR INFORMATION DERIVED FROM THESE DRAWINGS WILL NOT BE MANUFACTURED BY OR FOR YOU OR DISCLOSED TO OTHERS WITHOUT THE PRIOR EXPRESS WRITTEN CONSENT OF THOMAS & BETTS CORP. THESE DRAWINGS ARE NOT TO BE COPIED OR REPRODUCED OR DISCLOSED TO OTHERS WITHOUT THE PRIOR EXPRESS WRITTEN CONSENT OF THOMAS & BETTS CORP. ALL DRAWINGS AND INFORMATION ARE TO BE RETURNED TO UPON DEMAND OR UPON COMPLETION OF PURPOSE FOR WHICH LENT. COPYRIGHT THOMAS & BETTS CORP. ALL RIGHTS RESERVED. ALL OTHER TRADEMARKS ARE THE PROPERTY OF THEIR RESPECTIVE OWNERS.