



2000 LM

CL-SWL-12

2000 LUMEN SUPER BRIGHT
EMERGENCY SOLAR WALL LIGHT

Scientific Light Distribution



Product Advantage

Turn up, down, left and right; light wherever you want. Easy installation.



Vertical Sliding

**DIRECT FIXTURE AS YOU WISH,
AMAZING LIKE A MAGIC CUBE.**



Horizontally Sliding



Item : CL-SWL-12	Fixture Power : 20W
Solar panel	
Power	Epoxy Mono-Crystalline , 1W
Li-ion battery	
Capacity	3.7V 14.8WH 2AH/PC
Charging/Discharging Temp	0~40°C/-20~60°C
Charging Time	20H
LED (OSRAM)	2835 39pcs ;
Color Temp	4000K , Ra 80+
Efficiency	100lm/W
UV LED	-
Performance	
Lighting Time in Rainyday	>10days
Control Mode	Button Switch , ON/OFF Long Press 1.5s
Lighting Mode	M1 : 50+PIR (2000 lm) / M2 : 0+PIR (2000 lm) / M3 :50lm Till dawn -
Mode Indication	M1 : Flash for one time , M2 : Flash for two times ; M3 : Flash for three times
Capacity Indication	-
PIR	120° , >5m
Core technology	ALS 2.1 / TCS 1.0
Solar Panel Autoclean	-
IP/IK Class	IP65 / IK10
Install Height	3m

SOLAR LIGHT I EXPLODED VIEW

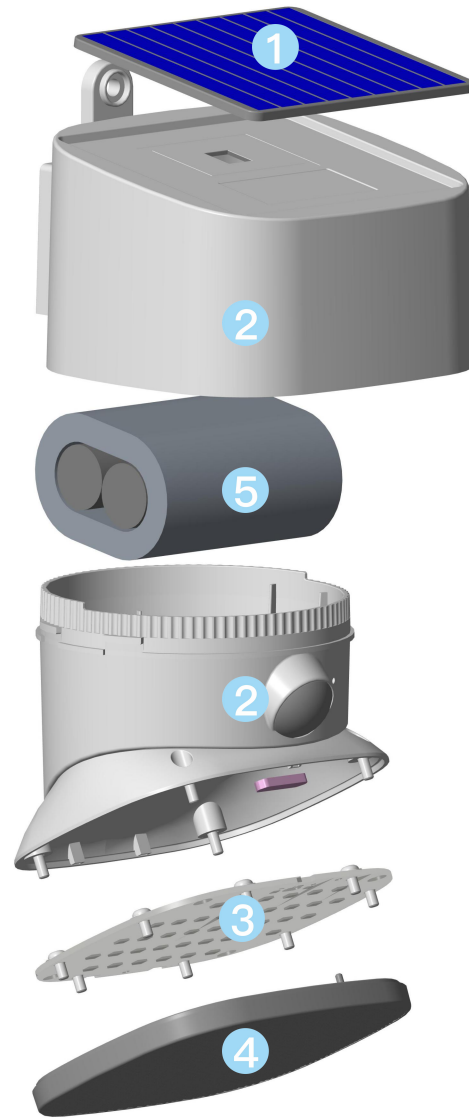

Solar panel



product shell



Led plate



optical lens



battery pack

Road Simulated Diagram

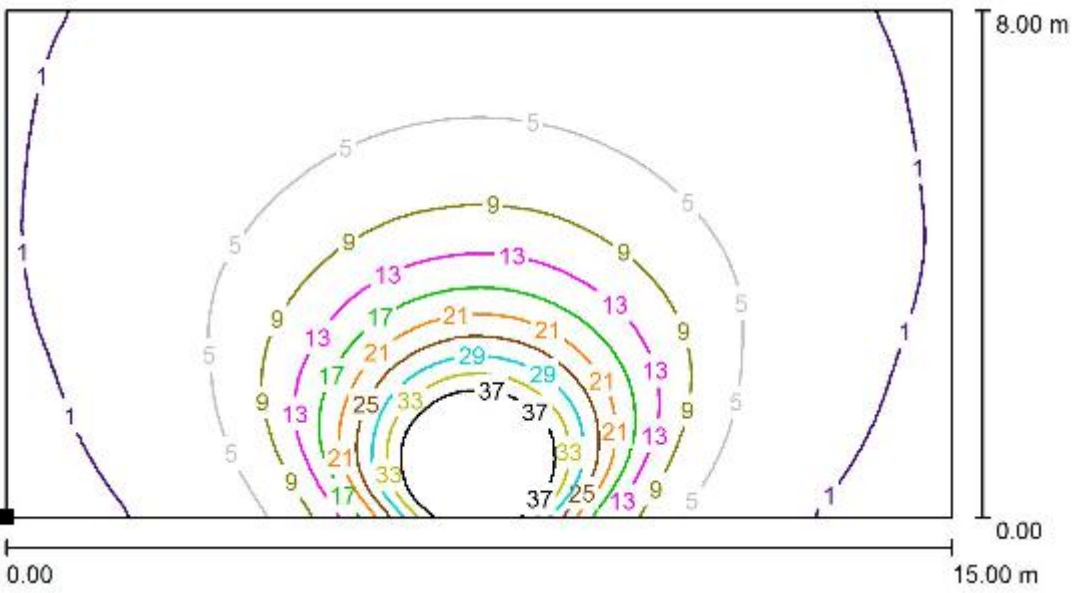

Illumination Curve

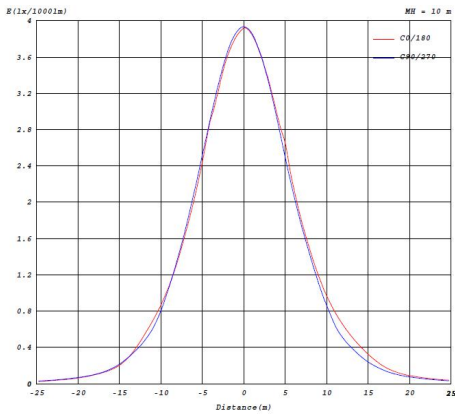

Luminance Distribution

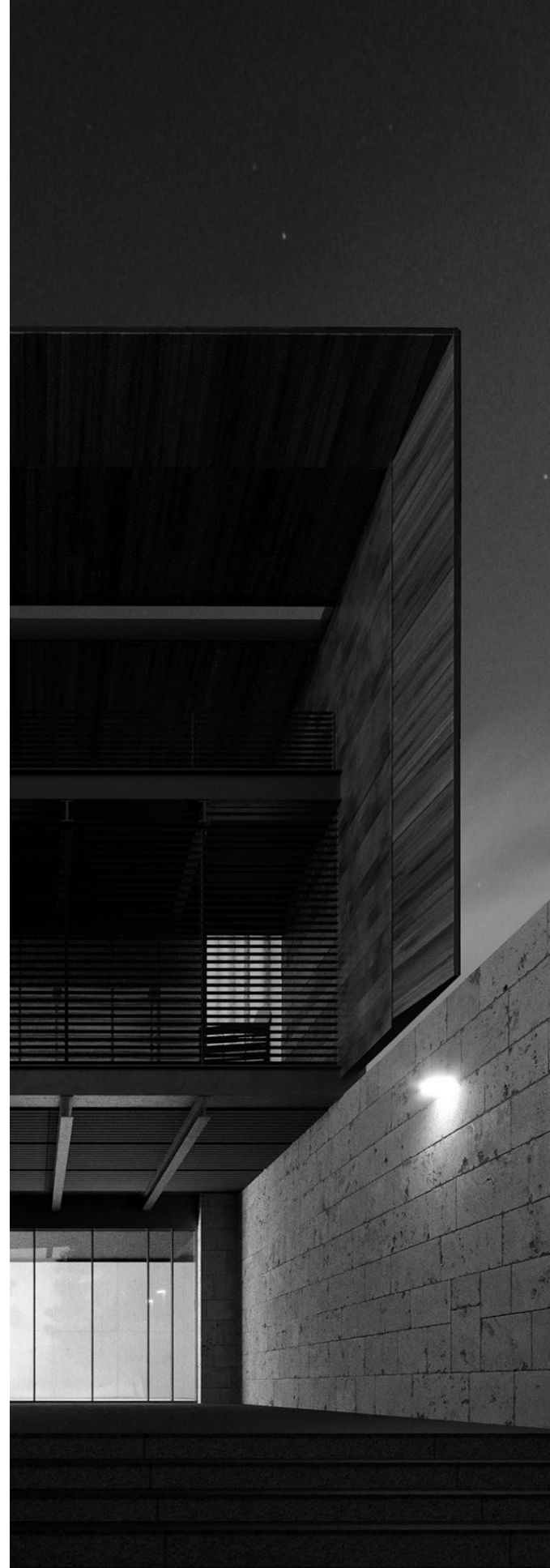
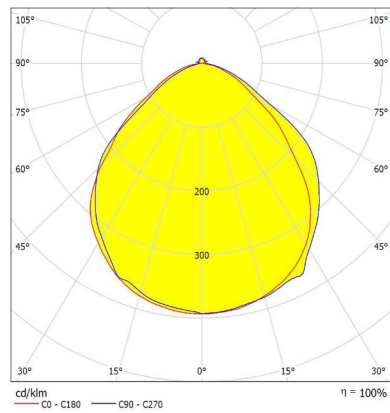

SOLAR LIGHT I DIMENTION FIGURE

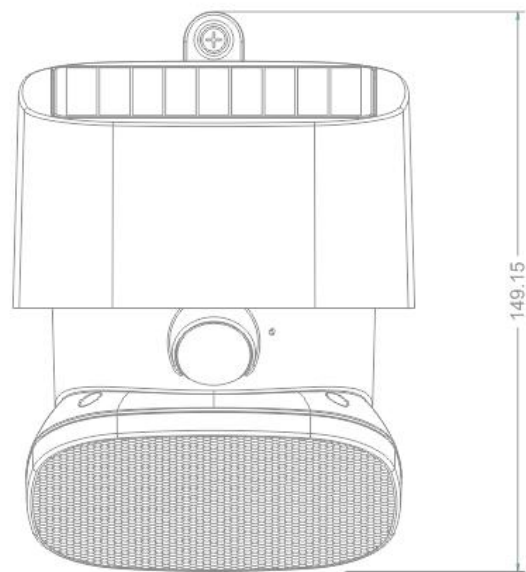
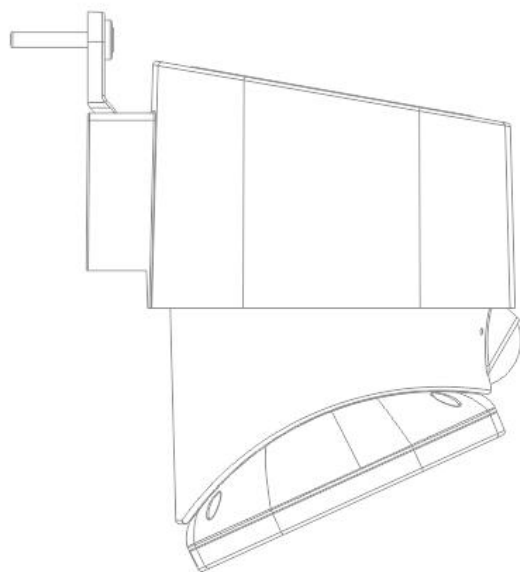
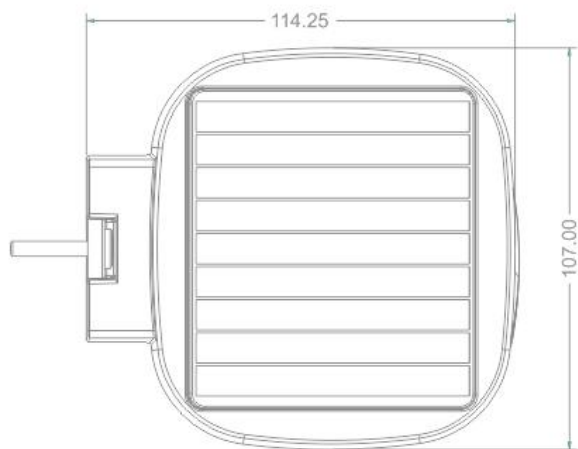

Advantage in every detail

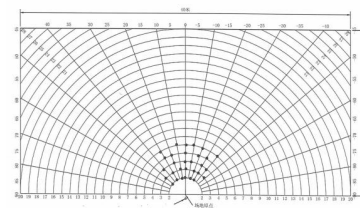

Monocrystalline
Solar Charging Efficiency :> 21%

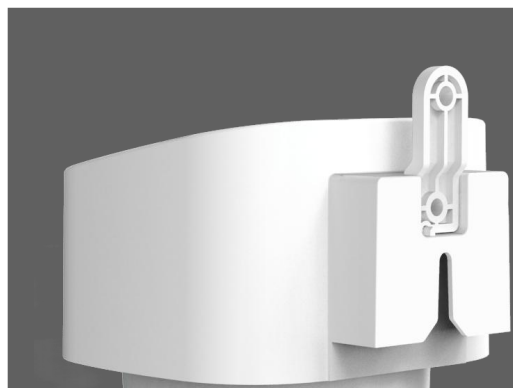

Easy to install

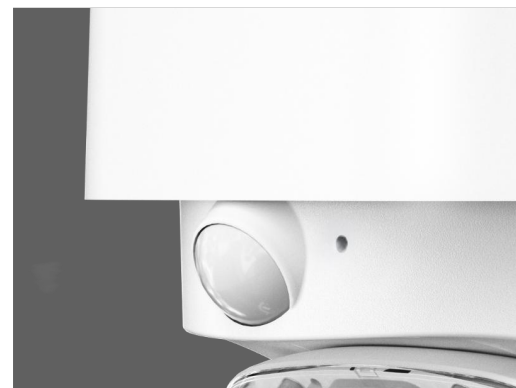

High sensitivity PIR sensor
Switches



Vertical sliding

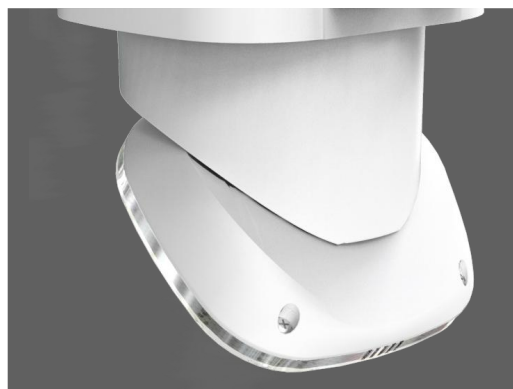

Back details



High lumen LEDs
190lm/W



A Great Company should always pay the highest attention to the every detail design , and the craftsmanship spirit should be filled in the whole design process and mass production.

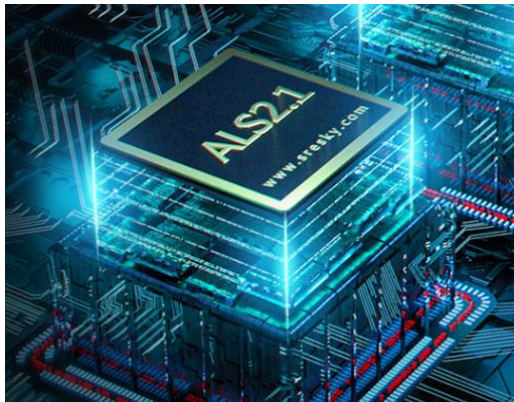

ADVANTAGE OF ALS

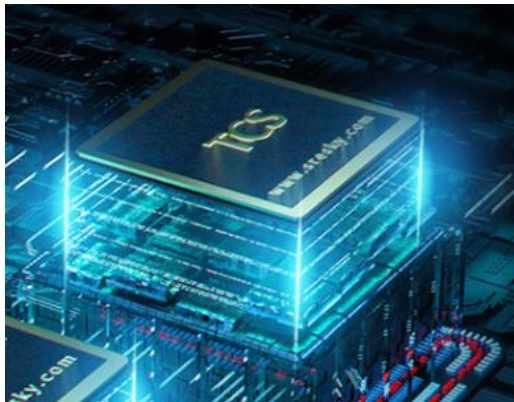
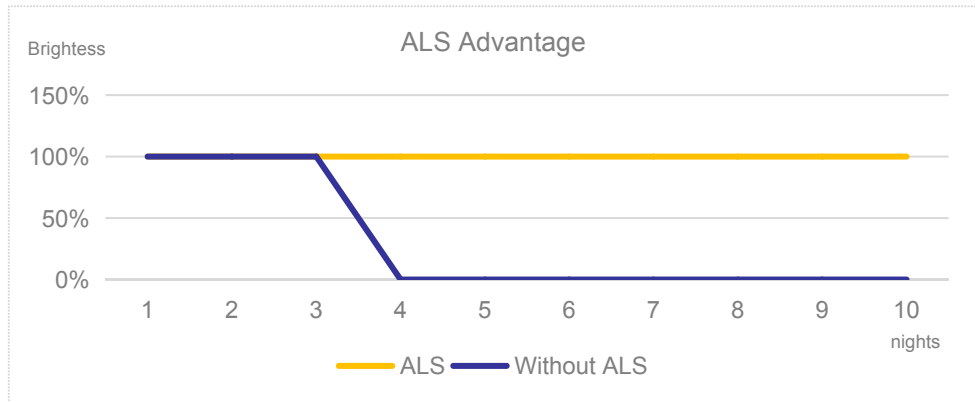

ADVANTAGE OF TCS

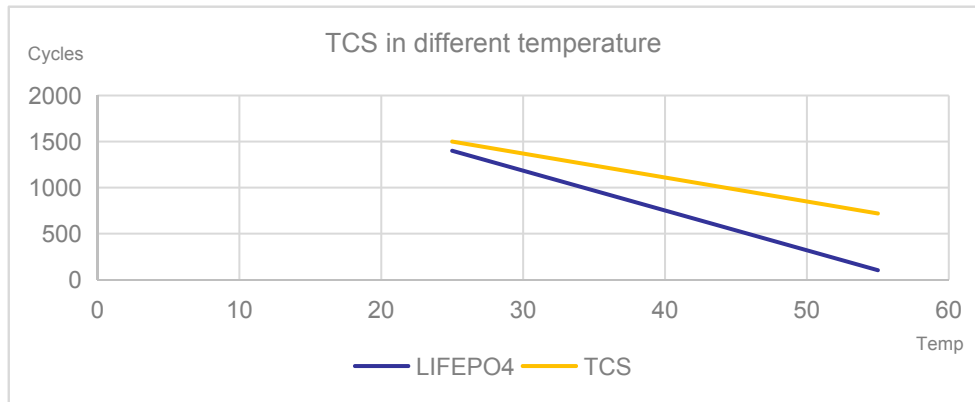

SOLAR LIGHT I PACKAGE DETAIL

PRODUCT LIST
 SCREW : 3PCS
 EXPANSION SCREWS : 2PCS
 ACCESSORIES : 1PC
 PIN: 1PC

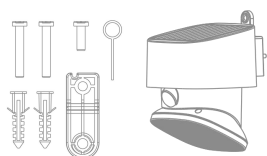

INNER COLOR BOX
 SIZE: 113*125*140mm
 1PCS/1 BOX



2 LAYERS
 1 LAYER = 12 BOXES

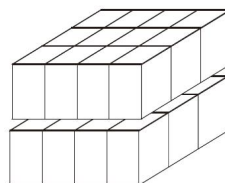

MASTER CARTON
 SIZE: 467*387*298mm
 24PCS/CTN

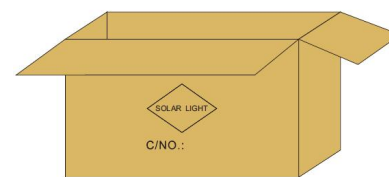

CARTON

LAYER NUMBER

COLOR BOX

PRODUCT LIST

STEP 1

STEP 2

STEP 3

STEP 4

MODEL NO.	PACKING METHOD	PCS/CTN	QTY(PCS)	CTN QTY	CARTON SIZE(MM)	N.W.(KG)	G.W.(KG)
CL-SWL-12	COLOR BOX	1	1	1	113*125*140	0.5	0.55
	CARTON	24	24	1	467*387*298	12	12.5

Net weight and gross weight are for reference only