



**SST/SST-U SERIES**

**IST/IST-U SERIES**

# superTube Heaters

LOW INTENSITY TUBE TYPE INFRARED HEATER  
WITH HIGH EFFICIENCY EC Motors

ANSI Z83.20-2016 • CSA 2.34-2016



## GENERAL INSTALLATION / OWNER'S MANUAL

A SUPPLEMENTARY MANUAL IS INCLUDED IN THE BURNER KIT FOR THE SPECIFIC MODEL



### WARNING

Improper installation, adjustment, alteration, service or maintenance can cause property damage, injury or death. Read the installation, operating and maintenance instructions thoroughly before installing or servicing this heater.



### SAFETY ALERT:

Do not store or use gasoline or other flammable vapours and liquids in the vicinity of this or any other gas fired appliance.

### IF YOU SMELL GAS:



- Extinguish any open flame
- Do not attempt to light this or any other appliance
- Don't touch any electrical switch, or telephone
- Immediately call your gas supplier from a neighbor's phone
- Follow any and all instruction from your gas supplier
- If your gas supplier is not available, call the fire department



### FIELD CONVERTIBILITY:

This appliance is field convertible to LP gas. Only use a kit available from manufacturer. Follow instructions provided in the kit and all local and national codes.

**Keep this manual in a secure place .**

Record for future reference:

Model #: \_\_\_\_\_

Serial #: \_\_\_\_\_

(located on heater rating label)

**NOTICE:**

*This manual is current and correct for this product at time of manufacture. Occasional revision of the product Certification Standard may require changes to the product and/or this manual.*

*This publication, or parts thereof, may not be reproduced in any form, without prior written consent from The Manufacturer. Unauthorized use or distribution of this publication is strictly prohibited.*

**Schwank Group**

Schwank and InfraSave brand products

*5285 Bradco Boulevard  
Mississauga, Ontario, L4W 2A6*

*2 Schwank Way  
Waynesboro, Georgia 30830*

**Customer & Technical Services**

*Phone: 877-446-3727*

*Fax: 866-361-0523*

*e-mail: [csr@schwankgroup.com](mailto:csr@schwankgroup.com)*

**[www.schwankgroup.com](http://www.schwankgroup.com)**


**[www.infrasave.com](http://www.infrasave.com)**

# SST & IST SERIES GENERAL MANUAL

LOW INTENSITY GAS FIRED INFRARED TUBE HEATERS

- ALSO REFER TO THE SUPPLEMENTARY MANUAL INCLUDED FOR SINGLE-STAGE, TWO-STAGE, and MODULATING MODELS

## GENERAL MANUAL: TABLE OF CONTENTS

TOPIC	..... PAGE	TOPIC	.....PAGE
 <b>IMPORTANT INFORMATION - READ FIRST</b>			
APPLICATION	4	9. BURNER & TUBE INSTALLATION:	
HEATER EXPANSION	5, 31	STRAIGHT TUBE SYSTEM	18
GAS CONNECTION	5, 31	SPECIAL COUPLING - 225 to 250 MBH	21
VENTING	5, 26	10. SEISMIC RESTRAINT	22
START UP 'SMOKE'	5	HIGH WIND RESTRAINT	22
THERMOSTAT SETTING / COMFORT	5	11. REFLECTOR INSTALLATION	23
TUBE 'GLOW'	6	REFLECTOR EXTENSIONS	23
CLEARANCE TO COMBUSTIBLES	6	12. GAS SUPPLY	24
Clearances Figure & Table	7&8	HEATER EXPANSION	25
STACKING HEIGHT SIGN	9	FLEXIBLE GAS CONNECTION	26
1. LABOR REQUIREMENTS	10	13. ELECTRICAL AND THERMOSTAT	27
2. INSTALLATION IN AIRCRAFT HANGARS	10	14. HIGH ALTITUDE INSTALLATION	27
3. COMMERCIAL GARAGES	10	15. LIGHTING INSTRUCTIONS	27
4. USE OTHER THAN SPACE HEATING	10	16. RECOMMENDED MAINTENANCE	27
5. PRE-INSTALLATION SURVEY	11	17. OPTIONAL ACCESSORIES	28
6. MOUNTING CLEARANCES	12	OPTIONAL CONTROLS	30
SERVICE CLEARANCE	12	WARRANTY STATEMENT	BACK PAGE
HEATER PLACEMENT GUIDELINES	13		
7. SYSTEMS WITH 90° & 180° ELBOWS	14	<b><u>SPECIFIC MODEL DATA, DIMENSIONS, WIRING DIAGRAMS, ETC.</u></b>	
ELBOW KIT INSTALLATION	15	REFER TO SUPPLEMENTARY MANUAL	
8. SUSPENSION OF THE SYSTEM	16	INCLUDED IN THE BURNER KIT FOR	
		THIS SPECIFIC MODEL	



## WARNING



Improper installation, adjustment, alteration, service or maintenance can cause property damage, injury or death. Read and understand this installation and operation manual thoroughly prior to assembly, installation, operation or service to this appliance.

This heater must be installed and serviced only by a trained gas service technician.

Do not store or use gasoline or other flammable vapours and liquids in the vicinity of this or any other gas fired appliance.



Failure to comply could result in personal injury, death, fire and/or property damage.

Do not store or use gasoline or other flammable vapours and liquids in the vicinity of this or any other gas fired appliance.



This appliance may have sharp edges and corners. Wear protective clothing such as gloves and protective eye wear when servicing this or any other appliance.

California Proposition 65:



**WARNING:** This product can expose you to chemicals including carbon monoxide, which is known to the State of California to cause birth defects or other reproductive harm. For more information, go to [www.P65Warnings.ca.gov](http://www.P65Warnings.ca.gov)

## APPLICATION

**SST/IST Series** gas-fired radiant tube heaters may be installed for heating of commercial / industrial indoor spaces. Not for use in residential dwellings.

A “residential dwelling” is defined in the standard as “a housekeeping unit used or intended to be used as a domicile by one or more persons, containing cooking, eating, living, sleeping, and/or sanitary facilities. A residential dwelling does not include an attached garage, detached garage, workshop or outdoors”. Local Code requirements take precedence.

It is beyond the scope of these instructions to consider all conditions and requirements that may be encountered in the field. Installation must conform with all local codes or, in the absence of local codes, with the latest edition of the National Fuel Gas Code, ANSI Z223.1/NFPA 54 in the U.S.A. or the Natural Gas and Propane Installation Code, CSA B149.1 in Canada. The latest edition Electrical Code ANSI/NFPA No. 70 in the U.S.A. and PART 1 CSA C22.1 in Canada must also be observed.

Installation of a gas fired tube heater must conform to all heating installation design procedures including clearance to combustibles, connection to the gas and electrical supplies, and ventilation requirements.

This heater is not for installation in a Class 1 or Class 2 explosive environment, nor in a residential dwelling. If installation of this equipment is in question, consult with the local authority having jurisdiction (Fire Marshall, labor department, insurance underwriter, or other).

Revisions to codes and/or standards, may require revision to equipment and installation procedures. In case of discrepancy, the latest codes, standards, and installation manual will take priority over prior releases.



## WARNING

### Heater Expansion



It is a normal condition that during heat-up and cool-down a tube heater will expand and contract. Allowances for heater expansion must be made in the gas connection, venting and combustion air ducting. Improper installation, alteration, or adjustment can result in property damage, injury or death. **Refer to Section 12**



## WARNING

### Gas Connection



Improper installation, connection, or adjustment can result in property damage, toxic gases, asphyxiation, injury or death. Using an approved flexible gas connector in the USA or Type 1 hose connector in Canada, the gas supply to the heater must be connected and tested in accordance with all local, state, provincial, and national codes (ANSI Z223.1/NFPA 54 in USA; B149.1 in Canada) and as indicated in this manual. **Refer to Section 12**



## WARNING

### Venting



Inadequate venting of a heater may result in asphyxiation, carbon monoxide poisoning, injury or death. This heater may be directly or indirectly vented from the space. Venting must be in accordance with all local, state, provincial, and national codes (ANSI Z223.1/NFPA 54 in USA; B149.1 in Canada) and as indicated in this manual. **Refer to Supplementary Model Manual Sections 5 & 6**



## WARNING

### Start-Up 'SMOKE' Condition

During start up, the heating of material coatings used in the production process of tubes and reflectors will create smoke during the initial period of operation. This condition is normal and temporary .

Ensure that there is sufficient ventilation to adequately clear any smoke from the space.

Notify site and safety personnel to ensure that alarm systems are not unduly activated.



## IMPORTANT

### THERMOSTAT SETTING FOR COMFORT

Infrared radiant (IR) heating system provide comfort from the effect of radiant heat and ambient air heat.

If your IR system is controlled by a thermostat that senses radiant heat (TruTemp or ThermoControl Plus), then set the thermostat to the actual desired comfort temperature (ie: 65°; 68°; 20°C).

If your IR system is controlled by a standard 24V or 120V thermostat that senses only air temperature, then start with a thermostat setting that is 5° to 7°F (3° to 5°C) lower than the desired comfort temperature. Some trial and error setting may be required to 'fine tune' the comfort temperature that best suits your site and provides most economical operation.



## WARNING

### Tube “GLOW”

It is a normal condition that the combustion tube (1st tube) can appear to “glow red”. For inputs up to 205,000 Btuh, the top surface of the tube can appear red where heat is trapped between the reflector and the tube. The stainless steel tube used for inputs 225,000 and greater can appear to entirely glow red. The tube material is designed into the heater because it can withstand the high temperature of combustion, and the “red glow” is a normal condition of the metallurgy of the tube material.



## WARNING

### Clearance to Combustibles

Location of flammable or explosive objects, liquids or vapors close to the heater may cause fire or explosion and result in property damage, injury or death. Do not use, store or locate flammable or explosive objects, liquids or vapors in proximity of the heater.



**The clearance to combustible material represents the minimum distance that must be maintained between the outer heater surface and a nearby surface. The stated clearance to combustibles represents a surface temperature of 90F° (50C°) above room temperature. It is the installer’s responsibility to ensure that building materials with a low heat tolerance which may degrade at lower temperatures are protected to prevent degradation. Examples of low heat tolerance materials include vinyl siding, fabrics, some plastics, filmy materials, etc.**

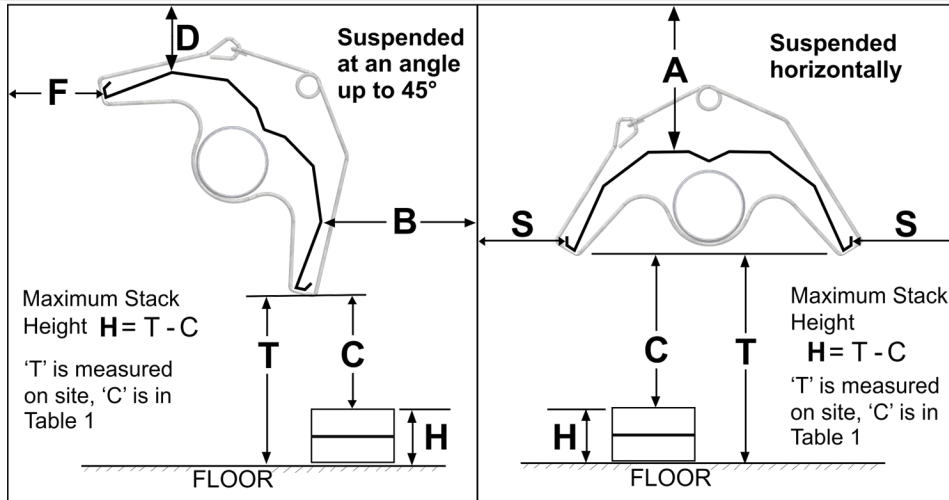
In locations used for the storage of combustible materials, signs must be posted to specify the maximum permissible stacking height to maintain the required clearances from the heater to the combustibles. Such signs must either be posted adjacent to the heater thermostats or in the absence of such thermostats in a conspicuous location. In addition to stored or stationary material, consideration must also be given to moveable objects such as cranes, vehicles, and overhead doors, and structural objects such as sprinkler heads, electrical and gas lines, and electrical fixtures.

It is beyond the scope of these instructions to consider all conditions that may be encountered in the field. Consult local authorities such as the Fire Marshall, insurance carrier, or safety authorities if you are uncertain as to the safety or applicability of the proposed installation.

**Refer to Figure 1 and Table 1 for the certified clearances to combustibles for the appropriate model input/size.**

**FIGURE 1A. MINIMUM CLEARANCES TO COMBUSTIBLES\*** - refer to Table 1 for values

**NOTE:** A 'PEEL & STICK' SIGN IS SUPPLIED: USE AN INDELIBLE MARKER TO ENTER VALUES 'H', 'S', 'F', & 'B' ON THE SIGN.  
 POST THE SIGN ADJACENT TO THE HEATER THERMOSTAT OR IN A PROMINENT LOCATION.




**TABLE 1A SST / IST MINIMUM CLEARANCES TO COMBUSTIBLES\***

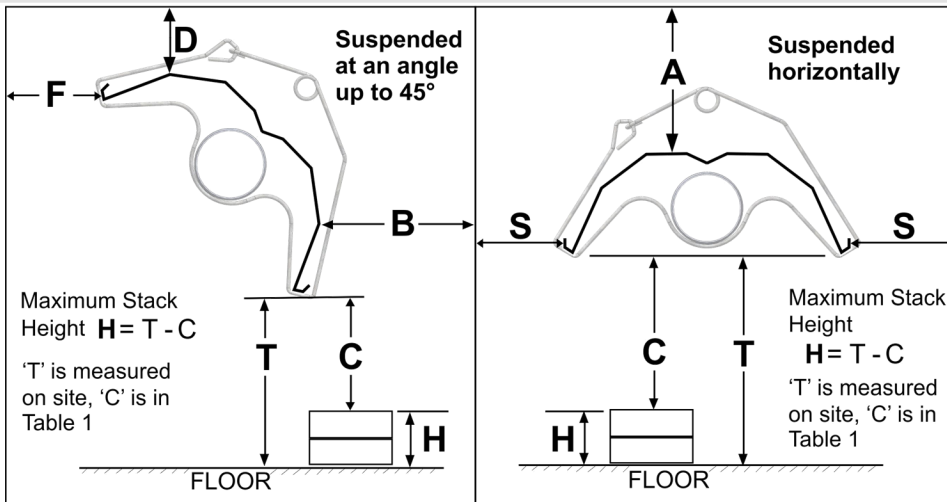
MODEL SST / IST Input Rate [BTUH]	SUSPENDED AT AN ANGLE UP TO 45 DEGREES				SUSPENDED HORIZONTALLY		
	D inches (mm)	B inches (mm)	F inches (mm)	C inches (mm)	A inches (mm)	S inches (mm)	C inches (mm)
50,000	4 (102)	3 (76)	40 (1016)	44 (1118)	4 (102)	20 (508)	42 (1067)
65,000	4 (102)	3 (76)	48 (1219)	50 (1270)	4 (102)	22 (559)	52 (1321)
80,000	5 (127)	3 (76)	54 (1372)	60 (1524)	5 (127)	24 (610)	62 (1575)
115,000	5 (127)	3 (76)	62 (1575)	70 (1778)	5 (127)	26 (660)	74 (1880)
130,000	7 (178)	3 (76)	64 (1626)	72 (1829)	6 (152)	28 (711)	78 (1981)
155,000	7 (178)	4 (102)	66 (1676)	74 (1880)	6 (152)	30 (762)	80 (2032)
180,000	8 (203)	4 (102)	72 (1829)	76 (1930)	7 (178)	36 (914)	84 (2134)
205,000	10 (254)	6 (152)	74 (1880)	78 (1981)	8 (203)	40 (1016)	88 (2235)
225,000	12 (305)	6 (152)	78 (1981)	78 (1981)	12 (305)	42 (1067)	92 (2337)
250,000	14 (356)	6 (152)	82 (2083)	78 (1981)	12 (305)	44 (1118)	95 (2413)

**\*NOTE: Clearances are measured from the reflector.**

The clearance to combustible materials represents the minimum distance that must be maintained between the heater and a nearby surface. **The stated clearance to combustibles represents a surface temperature of 90F° (50C°) above room temperature.**

**FIGURE 1B. MINIMUM CLEARANCES TO COMBUSTIBLES (U-Tube Models)- refer to Table 2 for values**

**NOTE:** A 'PEEL & STICK' SIGN IS SUPPLIED: USE AN INDELIBLE MARKER TO ENTER VALUES 'H', 'S', 'F', & 'B' ON THE SIGN.  
 POST THE SIGN ADJACENT TO THE HEATER THERMOSTAT OR IN A PROMINENT LOCATION. See next page for details.



**TABLE 1B SST-U / IST-U MINIMUM CLEARANCES TO COMBUSTIBLES (U-Tube Models)**

MODEL SST-U / IST-U Input Rate [BTUH]	SUSPENDED AT AN ANGLE UP TO 45 DEGREES				SUSPENDED HORIZONTALLY		
	D inches (mm)	B inches (mm)	F inches (mm)	C inches (mm)	A inches (mm)	S inches (mm)	C inches (mm)
50,000	6 (152)	3 (76)	42 (1067)	46 (1168)	4 (102)	20 (508)	48 (1219)
65,000	6 (152)	3 (76)	50 (1270)	52 (1321)	4 (102)	22 (559)	54 (1372)
80,000	8 (203)	3 (76)	60 (1524)	64 (1626)	6 (152)	24 (610)	66 (1676)
115,000	10 (254)	3 (76)	66 (1676)	72 (1829)	6 (152)	28 (711)	78 (1981)
130,000	12 (305)	3 (76)	66 (1676)	72 (1829)	8 (203)	30 (762)	80 (2032)
155,000	12 (305)	4 (102)	72 (1829)	78 (1981)	8 (203)	32 (813)	84 (2134)
180,000	15 (381)	4 (102)	72 (1829)	78 (1981)	10 (254)	36 (914)	88 (2235)
205,000	15 (381)	6 (152)	80 (2032)	82 (2083)	10 (254)	40 (1016)	90 (2286)
225,000	18 (457)	6 (152)	82 (2083)	84 (2134)	15 (381)	44 (1118)	95 (2413)
250,000	18 (457)	6 (152)	84 (2134)	86 (2184)	15 (381)	48 (1219)	100 (2540)

**\*NOTE: Clearances are measured from the reflector.**

The clearance to combustible materials represents the minimum distance that must be maintained between the heater and a nearby surface. **The stated clearance to combustibles represents a surface temperature of 90F° (50C°) above room temperature.**



**It is the installer’s responsibility to ensure that building materials with a low heat tolerance which may degrade at lower temperatures are protected to prevent degradation. Examples of low heat tolerance materials include vinyl siding, fabrics, some plastics, filmy materials, etc.**

**VENT END CLEARANCE:** Clearances from the vent pipe are determined by local or national installation codes, but must not be less than 6 inches (15 cm). For ‘unvented’ installation, a minimum distance of 48 inches (122 cm) is required from the end of heater to a combustible surface.



**WARNING** In locations used for the storage of combustible materials: **Signs must be posted** specifying the *maximum permissible stacking height* to maintain the required clearances from the heater to the combustibles.

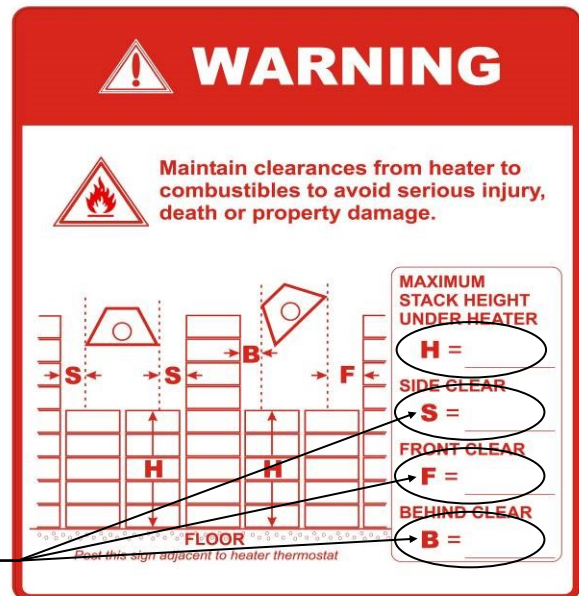
The signs must be posted either adjacent to the IR heating system thermostats or in the absence of such thermostats, in a conspicuous place.

A “peel and stick” sign is provided with this heater (look in manual). Use a permanent marker to record the required dimensions on the sign for the heater model installed.

To calculate the value ‘H’: ( $H = T - C$ )

- Measure the on site distance between bottom of the heater and the floor = ‘T’ inches (cm).
- Refer to Table 1 to get the value ‘C’ that corresponds to the model you are installing
- Subtract the clearance below the heater ‘C’ from ‘T’ to get value ‘H’.
- Enter this value ‘H’ on the sign.

Refer to the information in Figure 1 and Table 1 for the heater model being installed to get the values for dimensions ‘S’, ‘F’ and ‘B’.



Post this sign as instructed above.

## 1. LABOR REQUIREMENTS

Two workers are required to safely install this equipment. Wear gloves and other required safety protection.

## 2. INSTALLATION IN COMMERCIAL AIRCRAFT HANGARS

Low intensity radiant tube heaters are suitable for use in aircraft hangars when installed in accordance with the latest edition of the Standard for *Aircraft Hangars*, ANSI/NFPA No 409 in the USA, or the Canadian *Natural Gas and Propane Installation Code*, B149.1.

- A. A minimum clearance of 10 ft (3 m) above either the highest fuel storage compartment or the highest engine enclosure of the highest aircraft which may occupy the hangar. The clearance to the bottom of the heater shall be measured from the upper surface of either the fuel storage compartment or the engine enclosure, whichever is higher from the floor.
- B. A minimum clearance of 8 ft (2.4 m) must be maintained from the bottom of the heater to the floor in other sections of the aircraft hangar, such as offices and shops, which communicate with areas for servicing or storage. Refer to Section 1 for proper mounting clearances to combustibles.
- C. Heaters must be located so as to be protected from damage by aircraft and other objects, such as cranes and movable scaffolding.
- D. Heaters must be located so as to be accessible for servicing and adjustment.

## 3. INSTALLATION IN COMMERCIAL GARAGES AND PARKING STRUCTURES

Low Intensity Heaters are suitable for use in commercial garages when installed in accordance with the latest edition of the Standard for *Parking Structures*, ANSI/NFPA 88A, or the Standard for *Repair Garages*, ANSI/NFPA No. 88B, or the Canadian *Natural Gas and Propane Installation Code*, B149.1.



### **WARNING**

An overhead heater shall be located high enough to maintain the minimum distance to combustibles, as shown on the heater rating plate, from the heater to any vehicles parked below the heater.

Overhead heaters shall be installed at least 8 ft (2.4 m) above the floor.

## 4. INSTALLATIONS OTHER THAN SPACE HEATING

Use for process heat or other applications that are not space heating will void the C.S.A. certification and product warranty. Process application of gas-fired equipment requires field inspection and/or certification by local authority having jurisdiction.



## WARNING



Improper installation, adjustment, alteration, service or maintenance can cause property damage, injury or death. Read and understand this installation and operation manual thoroughly prior to assembly, installation, operation or service to this appliance.



This heater must be installed and serviced only by a trained gas service technician.

Do not store or use gasoline or other flammable vapours and liquids in the vicinity of this or any other gas fired appliance.



Failure to comply could result in personal injury, death, fire and/or property damage.

Do not store or use gasoline or other flammable vapours and liquids in the vicinity of this or any other gas fired appliance.

## 5. PRE INSTALLATION SURVEY

It is recommended that a full heating design including heat loss calculation be conducted on the structure or area to be heated. Heater sizing and placement must consider available mounting height, sources of greatest heat loss, and the certified clearances to combustibles with respect to stored material, moveable objects (cranes, vehicles, lifts, overhead doors, etc), sprinkler system heads, and other obstructions on the site. Consideration must also be given to vent / duct placement and the allowable combined lengths of vent and duct. Carefully survey the area to be heated, and for best results place burner and combustion chamber in the coldest area(s) .

Installation must conform with all local, state, provincial and national code requirements including the current latest edition ANSI Z223.1 (NFPA 54) in the U.S.A. and B149.1 installation code in Canada, for gas burning appliances and equipment. The latest edition Electrical Code ANSI/ NFPA N0 70 in the U.S.A. and PART 1 CSA C22.1 in Canada must also be observed.

The heating system must have gas piping of the correct diameter, length, and arrangement to function properly. For this reason, a layout drawing is necessary.

## **6. MOUNTING CLEARANCES**

This heater must be mounted with at least the minimum clearances between the heater and combustibles as shown in Figure 1 and Table 1. It is the installer's responsibility to ensure that building materials with a low heat tolerance which may degrade at lower temperatures are protected to prevent degradation. Examples of low heat tolerance materials include vinyl siding, fabrics, some plastics, filmy materials, etc.

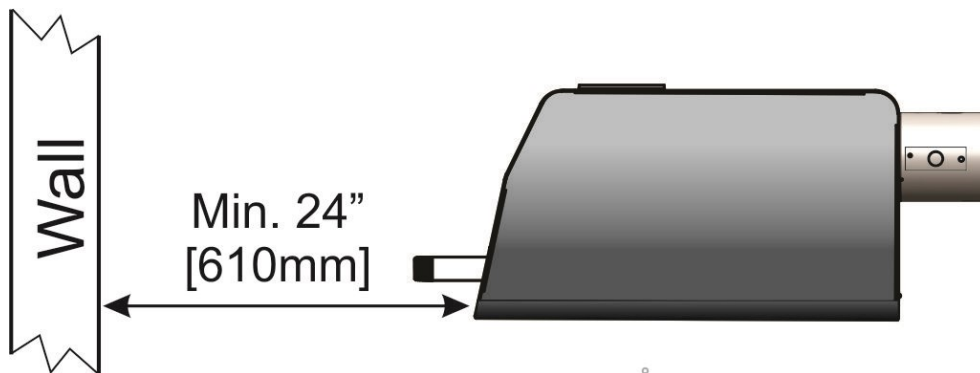
Positioning of lights, sprinkler heads, overhead doors, storage areas, gas and electrical lines, parked vehicles, cranes and any other possible obstruction or hazard must be evaluated prior to installation.

**Ensure adequate clearance around the air intake at the burner to allow sufficient combustion air supply to the heater.**

Guidelines for heater placement refer to Table 2.

**SERVICE CLEARANCE TO BURNER:** The lower 'jaw' of the burner cabinet swings down to provide convenient service access to burner components. Provide a minimum clearance from any wall or obstruction of 24 inches (610 mm) to the access end of the burner housing (refer to Figure 2) - the minimum clearances to combustibles must always be maintained above, below, and to the sides of the tube/reflector system.

**FIGURE 2 SERVICE CLEARANCE TO BURNER**



**TABLE 2: GUIDELINES FOR HEATER PLACEMENT**

MODEL HIGH INPUT (BTUH)	TYPICAL MOUNTING HEIGHT* ft (m)	MAXIMUM DISTANCE BETWEEN HEATERS ft (m)	DISTANCE BETWEEN OUTSIDE WALL AND PARALLEL HEATER LONG AXIS ft (m)	
			HORIZONTAL ft (m)	ANGLE
50,000	8 – 16 (2.5 - 5)	20 (6)	8 – 12 (2.5 - 4)	COMBUSTIBLE CLEARANCE BEHIND (refer to Table 1)
65,000	8 – 18 (2.5 - 5.5)	25 (8)	11 – 15 (3.4 - 5)	
80,000	10 – 20 (3 - 6)	30 (9)	12 – 16 (4 - 5)	
115,000	13 – 22 (4 - 7)	35 (11)	13 – 18 (4 - 6)	
130,000	15 – 25 (5 - 8)	40 (12)	15 – 20 (5 - 7)	
155,000	16 – 28 (5 - 8.5)	45 (14)	15 – 20 (5 - 7)	
180,000	18 – 30 (6 - 9)	50 (15)	17 – 25 (5 - 8)	
205,000	18 – 35 (6 - 11)	50 (15)	17 – 25 (5 - 8)	
225,000	20 – 40 (6 - 12)	60 (18)	20 – 30 (6 - 9)	
250,000	25 – 50 (8 - 15)	70 (21)	25 – 35 (8 - 11)	

\* TYPICAL MOUNTING HEIGHT provides optimum comfort in general space heating applications. Variance from the typical height can occur in applications:

- Higher mounting heights due to structure or application requirements
- Lower mounting heights for area or ‘spot’ heat, or in areas with greater air movement / infiltration losses (near overhead doors, etc)
- Lower mounting height when the diagonal distance from a heater to personnel provides a distance value similar to the Typical Mounting Height



**IMPORTANT:** Single or multiple heater placement must be such that continuous operation of heater(s) will not cause combustible material or materials in storage to reach a temperature in excess of ambient temperature plus 90 F° (50 C°).

**It is the installer’s responsibility to ensure that building materials with a low heat tolerance which may degrade at lower temperatures are protected to prevent degradation. Examples of low heat tolerance materials include vinyl siding, fabrics, some plastics, filmy materials, etc.**

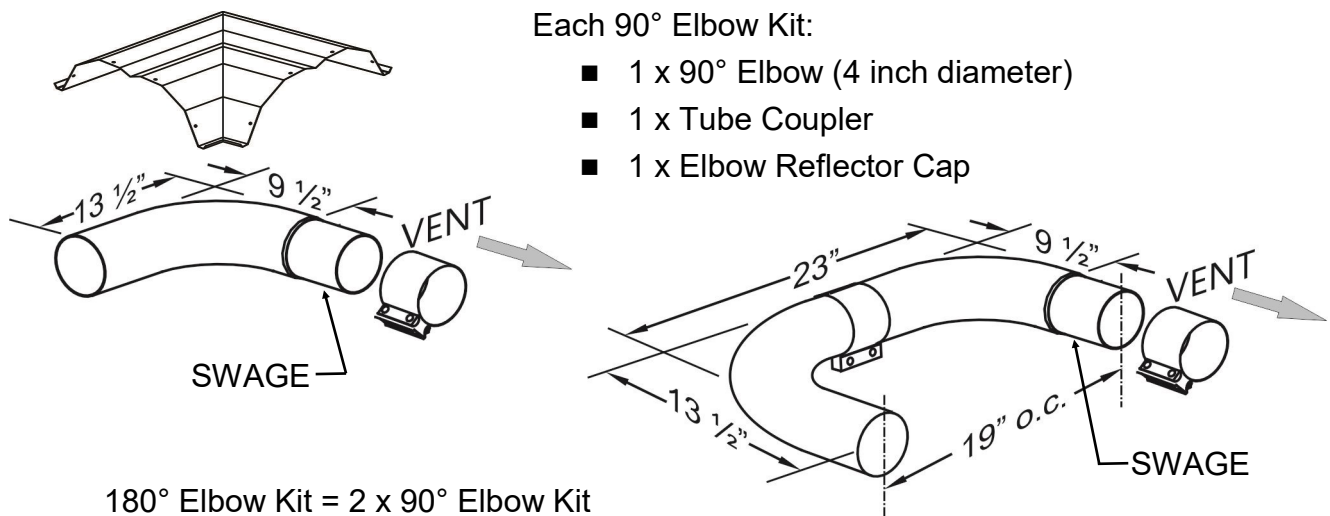
**Refer to “Clearance to Combustibles” information on pages 6 to 8, and Figure 1 and Table 1.**

## 7. SYSTEMS INCORPORATING 90° ELBOWS AND 180° ELBOWS

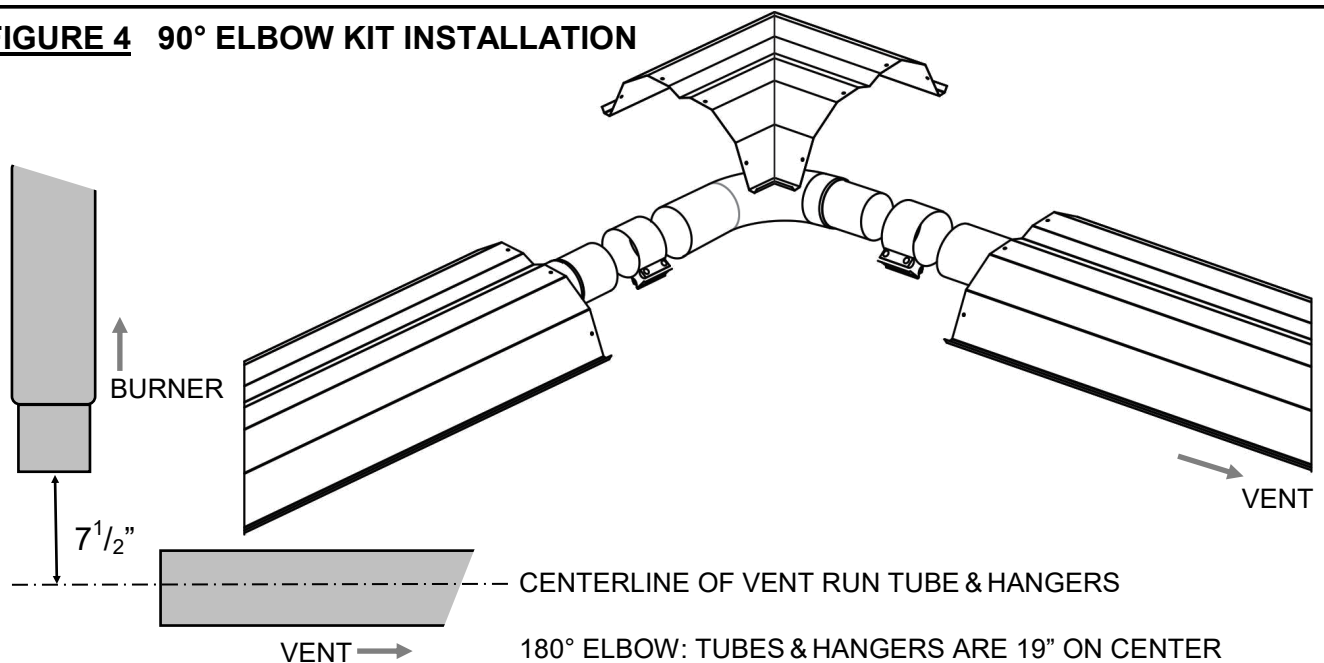
The radiant tube heater can be installed in configurations as illustrated in Figure 4 with a maximum of two 90° elbows per heater. Each elbow in the system is equivalent to 5 lineal feet that is part of the maximum total system length. (See Section 11 : Flue venting)

A 90° elbow kit (JS-0508-SST) includes one 90° elbow, one tube coupler, one elbow reflector, and two web brackets. For a 180° elbow, order 2 x 90° kits that assemble to create a 180°.

**FIGURE 3 SYSTEM ELBOW KIT - JS-0508-SST**

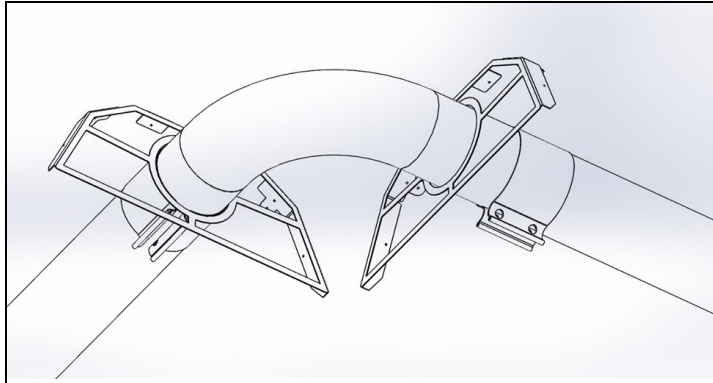


**FIGURE 4 90° ELBOW KIT INSTALLATION**



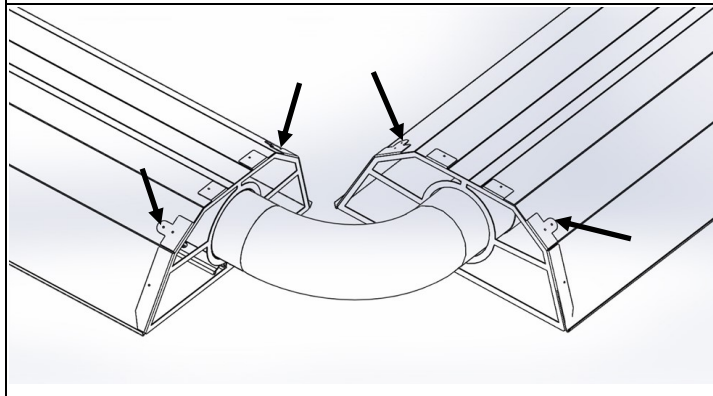
## INSTALLATION INSTRUCTIONS FOR 90° ELBOW KIT

When installing systems that incorporate a 90° elbow, assembly of the system is facilitated by first locating and installing the elbow assembly, then install the remainder of the tube/ reflector system working away from the elbow.

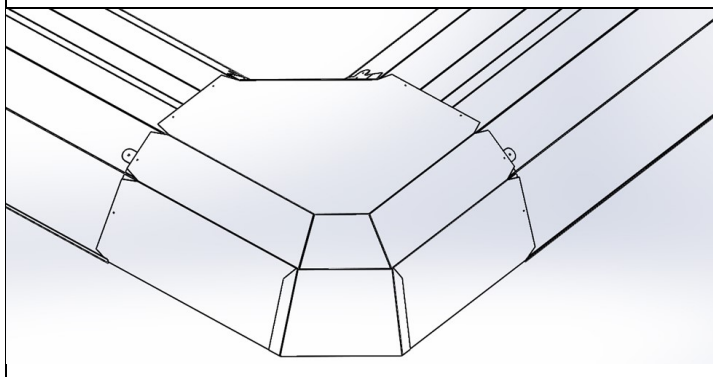


Add the coupler to the 90° elbow over the swaged end of the elbow. Slacken the coupler bolts. Slide the coupler over the elbow from the swaged end.

Add the plate hanger to the system at the same end where the coupling is located. The plate hanger must be installed with the cavity side facing toward the coupler/reflector.



Secure the plate hangers to the reflector with sheet metal screws provided.



Place the reflector over the plate hangers. Secure reflector to hangers with sheet metal screws provided.

**IMPORTANT: Elbow Location / Input:** A minimum run of straight radiant tube must be connected to the burner before any elbow as follows:



- Inputs 250 MBH and 225 MBH = 30 ft
- Inputs 205 MBH and 180 MBH = 25 ft
- Input 155 MBH = 20 ft
- Inputs 130 MBH and 115 MBH = 15 ft
- Inputs 80 MBH, 65 MBH, and 50 MBH = 10 ft

## 8. SUSPENDING THE SYSTEM - GENERAL



Inadequate or improper suspension of the tube heater can result in collapse of the system, property damage, and personal injury or death.

It is the installer's responsibility to ensure that the hardware and structural supports from which the heater is suspended are sound and of adequate strength to support the weight and expansion forces of the heater.

Consider that the heater will expand in length as much as 1/2 inch (12.5 mm) or more for every 10 ft (3 m) of system length – typically the greater the input rate, the greater the expansion.

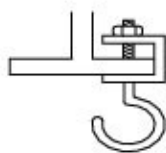
- 1) Survey the available structural supports, considering the system configuration and heat requirements of the area to establish the optimum heater location.
  - a) Locating a heater directly under joists or beams, or installing supplemental steel support rail or angle iron can substantially reduce labor and materials
- 2) Hardware with a minimum 60 lb. (30 kg) work load must be used at each heater suspension point. A #8 Jack Chain or equivalent is typically used for suspending the heater.
  - a) Connect to the structure using typical hardware as illustrated in Figure 6 or by other mechanically sound means
  - b) If rigid devices such as 3/8" threaded rods are used for suspension, swing joints or other means must be provided to allow for system expansion - approximately 1/2 inch to 1 inch for every 10 ft (1 cm to 2.5 cm for every 3 m) of system length.
- 3) Tube system hangers must be located:
  - i: Straight in line
  - ii: At a common height (tube level)

NOTE: It is important that the tubes in the system are installed in alignment horizontally (level) and vertically (in line) – this will ensure system integrity

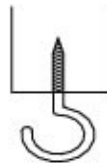
**FIGURE 6 TYPICAL MOUNTING HARDWARE**



HOOK OR EYE BOLT



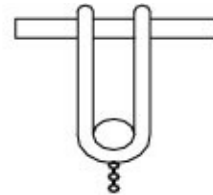
BEAM CLAMP WITH HOOK OR



HOOK OR



PIPE RING



BAR-JOIST CLAMP



NOTE: It is the installer's responsibility to ensure that mounting hardware and fastening to structure are of sufficient strength to support the system.



## 9 INSTALLATION OF HANGERS, TUBES AND BURNER

### IMPORTANT SPECIAL NOTES: READ FIRST

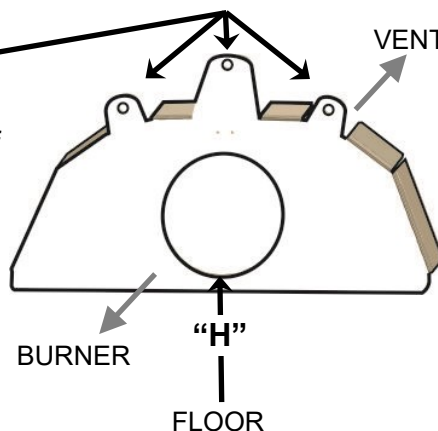
1. **Inputs 225 & 250 MBH:** Special Tube Connection - Refer to Section 9.2, Fig 11  
These input rates have an unpainted stainless steel first tube and second tube, and an unpainted aluminized steel tube as the third tube; all subsequent tubes are hot rolled steel. The first tube (stainless steel ) will “glow red” while heater is in operation - THIS IS A NORMAL CONDITION
3. IF a 90° elbow is to be installed in the system, **refer NOW** to Section 7 and the Elbow Kit installation instructions supplied with the kit
4. If a **Torcrite tube coupler** is removed or loosened for any reason after the heater has been put into service, the coupler must be replaced with a new one. A used, heated coupler will not be able to be torqued properly for tight grip. Part Numbers: Aluminized steel Torcrite coupler: JA-0516-SW; Stainless steel Torcrite coupler: JA-0516-SS

## 9.1 SST / IST SERIES: TUBE AND BURNER INSTALLATION

Refer to the Single-Stage , Two-Stage Model, or Modulating Supplementary Manual for turbulator locations and tube kit assemblies for the various model input rates.

- 1) At each hanger use chain, cable, and/or other hardware rated for minimum 100 lb [45.5 kg] load
  - i: The first hanger (plate hanger at burner end) is to be located no closer than 3" [75mm] and no further than 5" [127mm] from the burner/tube connection
  - ii: Subsequent wire hangers are to be located no closer than 6" (15 cm) either side of a tube connection in the system, and no further than 24" (61 cm) either side of a tube connection in the system

- 2) The first hanger at the burner end is a plate hanger with 3 suspension tabs.
  - i. Use the center suspension tab for horizontal orientation of the reflector, or one of the side suspension tabs for angle mount of the reflector (45°) over the tube
  - ii. Suspend the plate hanger so that the bottom of the tube-opening in the hanger is at the desired height for the tube above the floor ("H")
  - iii. The reflector attachment flanges on the plate hanger face away from the burner



- 3) Suspend the next hanger (wire hanger) in alignment and at the same tube height as the plate hanger
  - i. Distance between first & second hangers is maximum 107" [2718 mm] and minimum 87" [2210 mm] ... also see 1) above.
- 4) Insert the combustion tube section into first two hangers with swaged end of tube toward the vent. The tube must be level along its length.

**NOTE: FROM BURNER END, INSTALL THE FIRST AND SECOND TUBES ONLY WITH THE WELDED SEAM (ALONG THE TUBE LENGTH) FACING DOWNWARD (in the bottom hemisphere).**

Labels on tubes identify those with turbulators and indicate their location in the system.

- 5) Install burner to combustion tube: SEE DETAILS - FIGURE 8 NEXT PAGE

**IMPORTANT NOTE: Models with inputs 180,000 to 250,000 refer to section 9.2**

- 6) Slide a Torctite tube coupler over the swaged end of the first tube, then join the second tube over the swage in the first tube

- 7) Slide the Torctite coupler into position across the center of the joint - SEE FIGURE 9

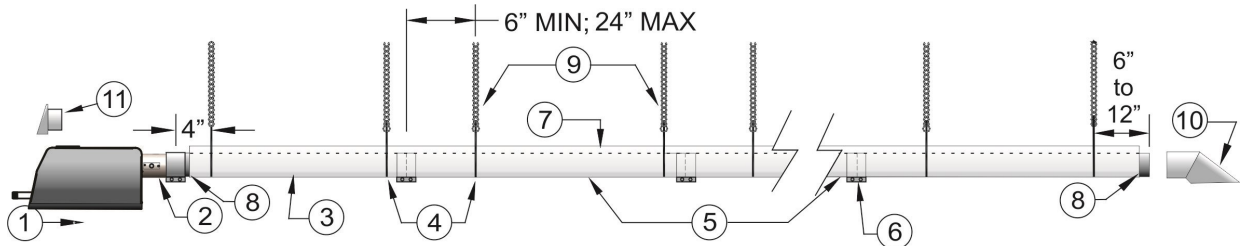
- 8) **IMPORTANT: TORQUE THE COUPLER BOLTS TO 40 lb-ft.**

**TORCTITE COUPLER CAN ONLY BE USED ONCE. IF COUPLER IS LOOSENED OR REMOVED FOR ANY REASON, REPLACE COUPLER WITH NEW ONE. TORCTITE COUPLER Part # JA-0516-SW**

9) Subsequent lengths of tube can then be installed, by inserting the swaged portion inside the next tube and locking the joint using the Torctite coupler. SEE FIGURE 9.

**NOTE:** For the 3rd and following tubes in the system: DO NOT install the welded seam facing downward along the length of the system after the first two tubes. Welded seams should randomly face toward one side or the other (3 or 9 o'clock), 90° up from bottom (6 o'clock).

**FIGURE 7: STRAIGHT TUBE TYPICAL HANGER & SUPPORT SPACINGS**



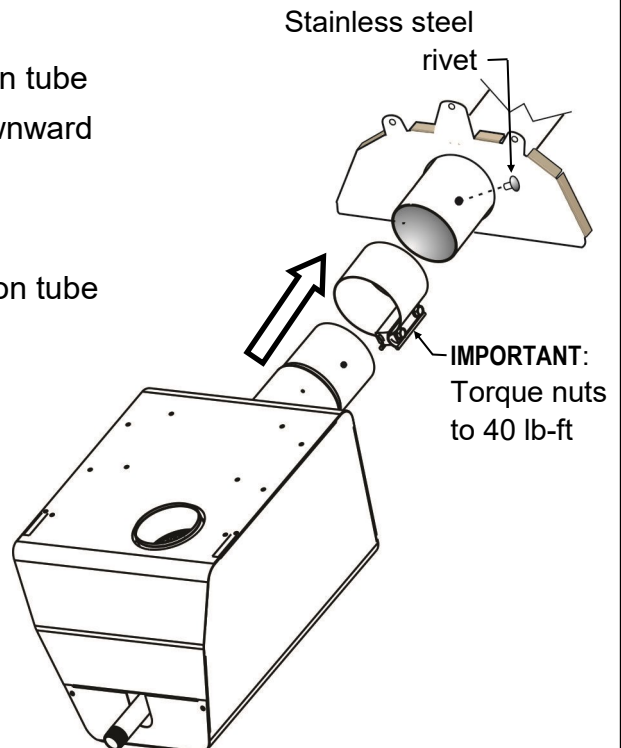
SUSPEND ALL TUBES BY TWO (2) HANGERS PER 10' LENGTH, LOCATE HANGERS BETWEEN 6" to 24" FROM EACH TUBE CONNECTION.

1ST & 2ND TUBES ONLY FROM BURNER END: INSTALL WELDED SEAM FACING DOWNWARD.

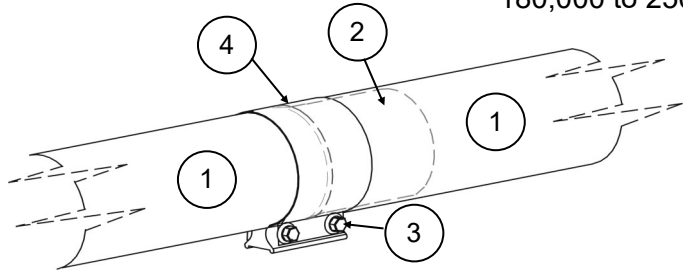
- |                                   |                                |                                     |
|-----------------------------------|--------------------------------|-------------------------------------|
| 1 - BURNER ASSEMBLY               | 4 - WIRE HANGERS               | 9 - HEATER SUSPENSION CHAIN / CABLE |
| 2 - SIGHT GLASS WIRE HANGER       | 5 - STEEL HEAT EXCHANGE TUBES  | OPTIONAL:                           |
| 3 - COMBUSTION TUBE:              | 6 - TORCTITE TUBE COUPLER      | 10 - FLUE VENT TERMINAL             |
| • UP TO 155,000: ALUMINIZED STEEL | 7 - ALUMINIZED STEEL REFLECTOR | 11 - 4" AIR DUCT WALL CAP           |
| • > 155,000: STAINLESS STEEL      | 8 - REFLECTOR END CAP          |                                     |

**FIGURE 8: INSTALL BURNER TO COMBUSTION TUBE**

1. Suspend combustion tube in first two hangers:
  - Hole for connection rivet at side of combustion tube
  - Welded seam of combustion tube facing downward
2. Slide tube coupler on to combustion tube (past the rivet hole in tube)
3. Insert the burner tube (swage) into the combustion tube
4. Align rivet holes in combustion and burner tubes. A screwdriver or similar tool can assist alignment
5. Insert rivet into the aligned holes
6. Slide tube coupler over rivet head and locate coupler half on burner tube and half on combustion tube
7. **IMPORTANT:** Torque coupler nuts to 40 lb-ft
8. Adjust (rotate) burner to ensure hanging plumb



**FIGURE 9: COUPLER INSTALLATION** (NOTE: See Section 9.2 for 'Special Couplers' at tube joints: 180,000 to 250,000 models)

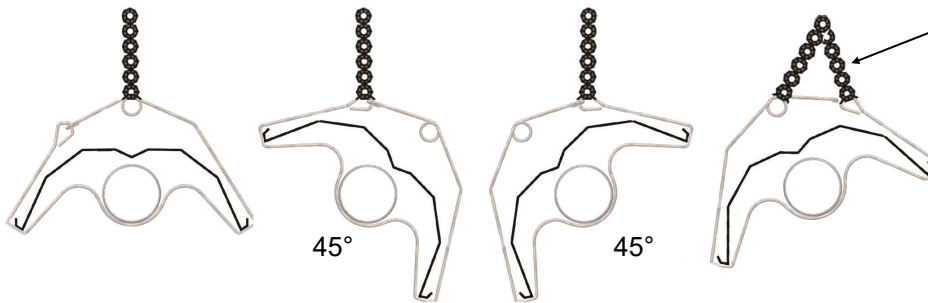


1. Tube
2. Swaged end of upstream tube
3. Tube Coupler

**NOTE: Coupler can be used only once. Replace any coupler that has been loosened or removed.**

4. Center coupler over tube joint
5. **Tighten coupler bolts to 40 lb-ft.**

**FIGURE 10: HANGER / REFLECTOR ORIENTATION HORIZONTAL TO 45°**



TO ACHIEVE AN ANGLE LESS THAN 45° USE CHAIN TO BOTH EYES ON HANGER . ADJUST CHAIN LENGTHS AS REQUIRED.



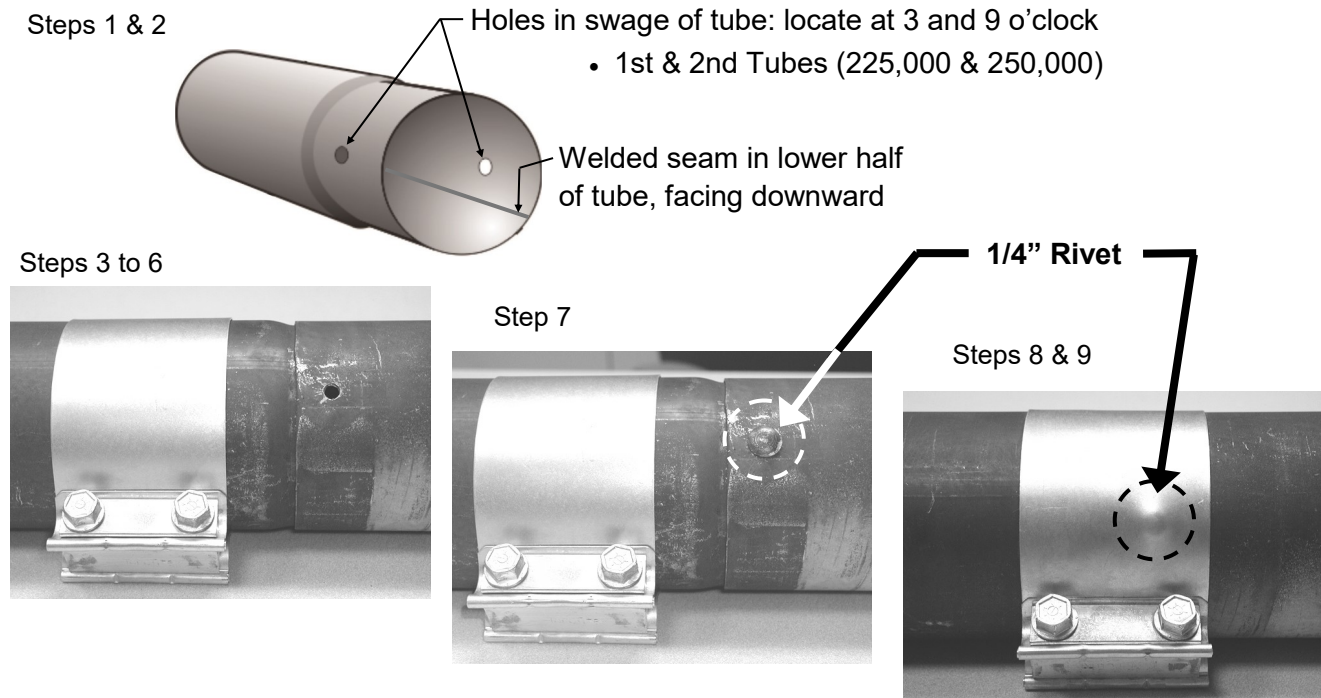
## 9.2 SPECIAL TUBE COUPLING: 225,000 to 250,000 Btuh

NOTE: The joint of 1ST & 2ND tubes (225,000 - 250,000) experience strong forces of expansion. Follow instructions below for special coupling of the first few tubes in the system.

### SPECIAL COUPLING: INSTALLATION

1. Note the 2 holes opposite each other at the swaged end of the first and second tubes (225,000 - 250,000)
2. Install the **first tube** with 2 holes (swaged end) at the 3 and 9 o'clock position, with the **welded seam located in the lower half of tube, facing downward**
3. Slide a loosened tube coupler on to the first tube, past the swage
4. The second tube has one single  $\frac{1}{4}$ " hole at the female end.
5. Slide second tube over swaged end of first tube to align the single hole in the second tube with either of the holes in the first tube
6. Final alignment of the outer and inner holes can be accomplished using a screw driver or other tool to align the edges of the holes
7. **IMPORTANT:** Insert  $\frac{1}{4}$ " stainless steel rivet into the hole to secure the tube connection
8. Slide coupler into position – half onto each tube – covering the rivet head
9. Tighten coupler bolts to 40 lb-ft
10. For inputs 225,000 - 250,000 repeat the connection process between the 2nd and 3rd tubes.
11. Install reflectors

**FIGURE 11 SPECIAL COUPLING: 225,000 to 250,000 Btuh**



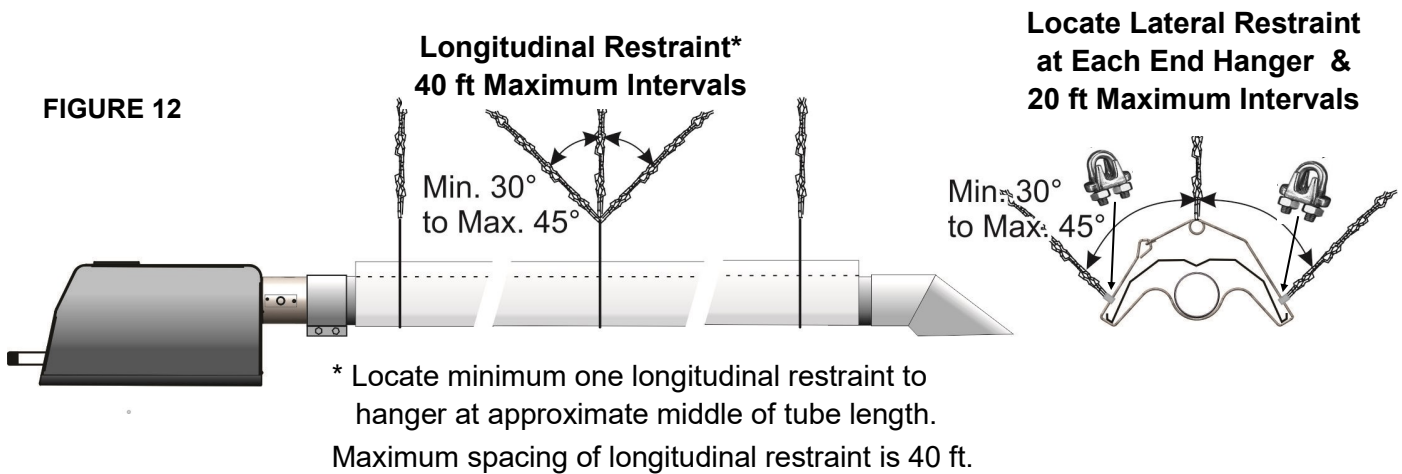
## 10. SEISMIC RESTRAINT GUIDELINES - LATERAL AND LONGITUDINAL

Tube must be allowed to expand and contract within the restrained hanger system. In areas prone to earthquake, or as specified on a project, install lateral and longitudinal seismic restraints as indicated in Figure 12. If the heater location can be impacted by wind (outdoors, aircraft hangars, etc) refer to High Wind Restraint Section 9.5, Figure 13.

These restraint systems indicate typical suspension of and attachment to the heater. Attachment of suspension hardware to the structure will be as required by site structural conditions, installation codes, and/or local engineering design requirements. Other material or systems of restraint may be specified by local or national codes, or by project engineering specifications.

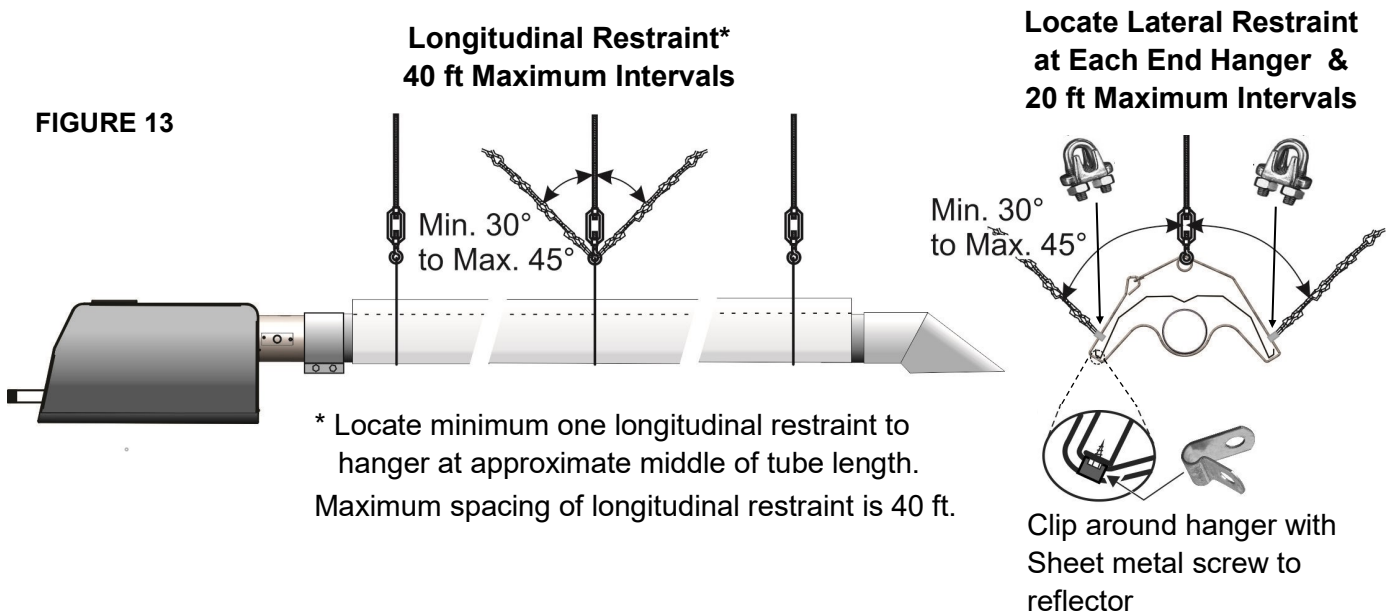
Schwank / InfraSave offers optional items: #2 Lion Chain 115 lb work load x 200 ft roll (PN: JL-0800-XX); and Safety Snap Hooks (PN: JL-0800-SH = pkg 24; JL-0800-SH-B = pkg 100).

- Any and all other required seismic mounting hardware is field supplied by the installer.



## HIGH WIND RESTRAINT GUIDELINES - LATERAL, LONGITUDINAL, AND VERTICAL

In areas with wind conditions (outdoors, near large doors, etc) in addition to lateral and longitudinal restraint the heater must be restrained from vertical movement. Suspend the heater using 3/8" threaded rod with 3" adjustment turnbuckle through a safety ring at each hanger location.



## 11. REFLECTOR INSTALLATION

**NOTE: Ensure that you are installing a single reflector - reflectors can ‘stick together’ in packaging - take care to separate them individually.**

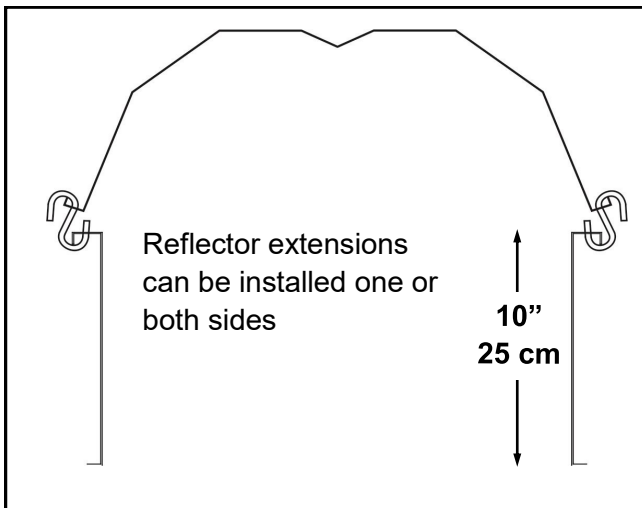
**SST / IST :** After burner and tubes have been installed, slide the reflectors one at a time into the wire hangers. As each successive reflector is installed on an in-line installation, the ends of the reflectors will overlap by approximately 4 inches [100mm] to provide continuous coverage over the entire tube system. The reflector overlap **MUST BE FASTENED TOGETHER** with a sheet metal screw each side of the reflector (field supplied).

Note that for either horizontal or angle mounting of the reflector, the tube must be level along its length. Improper mounting can result in overheating of controls and combustible materials.

Reflector extensions can be added to the heaters as an option. See *Figure 14 below*

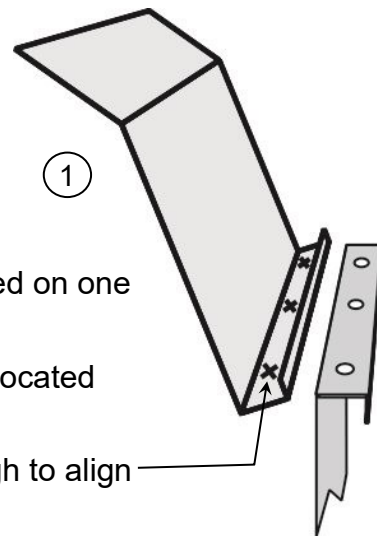
**FIGURE 14 REFLECTOR EXTENSIONS**

(OPTIONAL - IF REQUIRED )



### Reflector Extension Kit JS-0509-KT

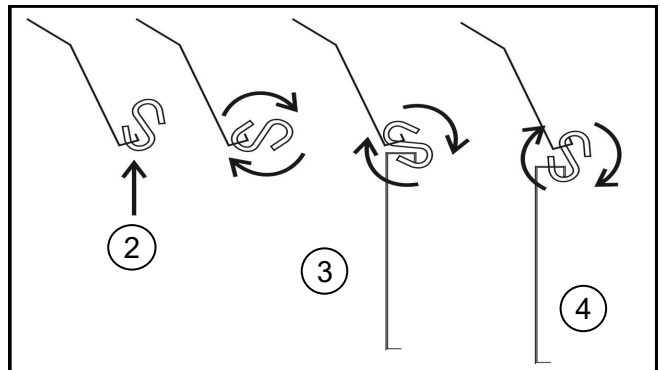
- Qty 1 x 10 ft long x 10 inch deep reflector extension
- Qty 3 x “S” Hooks



Reflector extensions are 116” (295 cm) long and can be installed on one side or both sides of the reflector

The three (3) holes in the reflector extension for “S” hooks are located 2.25” (5.7 cm) from each end and one at the center

1. Drill 3 x 1/4” (7 mm) holes in the center of the reflector trough to align with the 3 holes in the top of the reflector extension
2. Insert “S” hook up through hole in the reflector extension trough
3. Rotate “S” hook approx. 90°, and insert lower end of S hook up into hole in reflector extension
4. Continue to rotate “S” hook until reflector extension settles into place



## 12. GAS SUPPLY - HEATER EXPANSION - FLEXIBLE GAS CONNECTION

The gas supply must be installed to the heater using:

- **USA:** an approved Stainless Steel Flexible Gas Connector certified for use on an infrared radiant tube heater (ANSI Z21.24 CSA 6.10);
- **CANADA:** an approved Type 1 Hose Gas Connector (CAN/CGA 8.1).
- The heater must be isolated from the gas supply piping system by closing its individual manual shut off valve (field supplied) during any pressure testing of the gas supply piping system.



**CAUTION:** Compensation for normal gas supply pipe expansion, and radiant tube heater expansion must be provided. All piping must conform to local codes.

Provide a 1/8 in (3.2 mm) NPT plugged tapping, accessible for test gauge connection, immediately upstream of the gas supply connection to the heater.



**DO NOT** use pressure greater than 1/2 psig to pressure check the heater.

**TEST FOR LEAKS:** All gas piping and connections must be tested for leaks after the installation is completed.



Apply soap suds solution to all connections and joints and if bubbles appear, leaks have been detected and must be corrected. **DO NOT USE A MATCH OR OPEN FLAME OF ANY KIND TO TEST FOR LEAKS. NEVER OPERATE THE HEATER WITH LEAKING CONNECTIONS.**

The supply system should be checked first with heater turned “OFF” followed by another check with heater turned “ON”.



**IMPORTANT:** Minimum supply line pressure at the inlet to the heater regulator must not be lower than 5.0 inches of water column pressure for natural gas, and 11.0” w.c. for propane gas. The supply gas pressure must be checked with all heaters in operation.

Installation of a gas line (trap) “drip leg” is required at the inlet connection tee following the pipe drop to the heater. Failure to provide a “drip leg” could result in condensation and foreign matter passing into the gas valve. Failure to install a “drip leg” in the gas line can cause property damage, injury or death and will void the heater warranty.

**TABLE 4**

INPUT	GAS TYPE	LINE PRESSURE INCHES WATER COLUMN		MANIFOLD PRESSURE (tap at gas valve outlet) INCHES WATER COLUMN
		MINIMUM	MAXIMUM	
Single Stage	Natural Gas	5.0	14.0	3.5 (4.2 for 225&250 Models)
	Propane Gas	11.0	14.0	10.0
Two Stage	Natural Gas	5.0	14.0	3.5 High / 2.0 Low
	Propane Gas	11.0	14.0	10.0 High / 5.0 Low
Modulating	Natural Gas	5.0	14.0	See Modulating Manual
	Propane Gas	11.0	14.0	See Modulating Manual

**NOTE:** Access to the manifold pressure test port is on the top of the valve. A 3/16" Allen Wrench is necessary to remove the plug from the port.

When checking or setting the manifold pressure, a **water manometer or accurate inches water column gauge** must be used. Gauges which measure ounces per square inch or pounds per square inch are not accurate enough to properly measure and set the pressure.





## WARNING

### HEATER EXPANSION



**THIS HEATER WILL EXPAND IN LENGTH AS IT HEATS UP.** It is a normal condition that during heat-up and cool-down a tube heater will expand and contract. Some expansion is toward the vent end, and some expansion is at the burner end. Allowances for heater expansion must be made in the gas connection, venting and combustion air ducting. Improper installation, alteration, or adjustment can result in property damage, injury or death.



The Btuh input and the tube length determine the overall expansion that occurs. A typical infrared tube installation will expand toward both the Burner and the vent end.



To allow heater expansion the gas supply must be installed using the flexible gas connector supplied in the burner kit:

**In the USA:** a stainless steel Flexible Gas Connector certified for use on an infrared radiant tube heater per the Standard for *Connectors for Gas Appliances*, ANSI Z21.24 CSA 6.10

**in CANADA:** a Type 1 Hose Connector (CAN/CGA 8.1). Also the flue vent, and combustion air intake (if used) must be installed in such a manner that the normal expansion of the heater will be accommodated.



**IMPORTANT:** See next page: orientation of flexible gas connector between heater and gas supply.

**TABLE 5: HEATER LENGTH EXPANSION & GAS CONNECTOR TYPE / SIZE**

High Input Rating Btuh	Tube Length Feet	Approximate System Expansion * in Length	USA: Mandatory Flexible Gas Connector ID x Length - Part #	CANADA: Mandatory Type '1' Gas Hose Size - Part #
50,000	20	1 1/4"	1/2" x 24" - JL-0771-XX	1/2" x 30" - JL-0771-RC
65,000	20 / 30	1 1/2"	1/2" x 24" - JL-0771-XX	1/2" x 30" - JL-0771-RC
80,000	20 / 30 / 40	1 3/4"	1/2" x 24" - JL-0771-XX	1/2" x 30" - JL-0771-RC
115,000	30 / 40 / 50	2"	1/2" x 24" - JL-0771-XX	1/2" x 30" - JL-0771-RC
130,000	30 / 40 / 50	2"	1/2" x 24" - JL-0771-XX	1/2" x 30" - JL-0771-RC
155,000	40 / 50 / 60	2 1/2"	1/2" x 24" - JL-0771-XX	1/2" x 30" - JL-0771-RC
180,000	50 / 60 / 70	2 3/4"	1/2" x 24" - JL-0771-XX	1/2" x 30" - JL-0771-RC
205,000	50 / 60 / 70	3 1/4"	1/2" x 24" - JL-0771-XX	1/2" x 30" - JL-0771-RC
225,000	60 / 70 / 80	3 1/2"	3/4" x 36" - JL-0771-YY	3/4" x 30" - JL-0771-RB
250,000	60 / 70 / 80	4"	3/4" x 36" - JL-0771-YY	3/4" x 30" - JL-0771-RB

\* Expansion is split in direction between the burner and vent ends

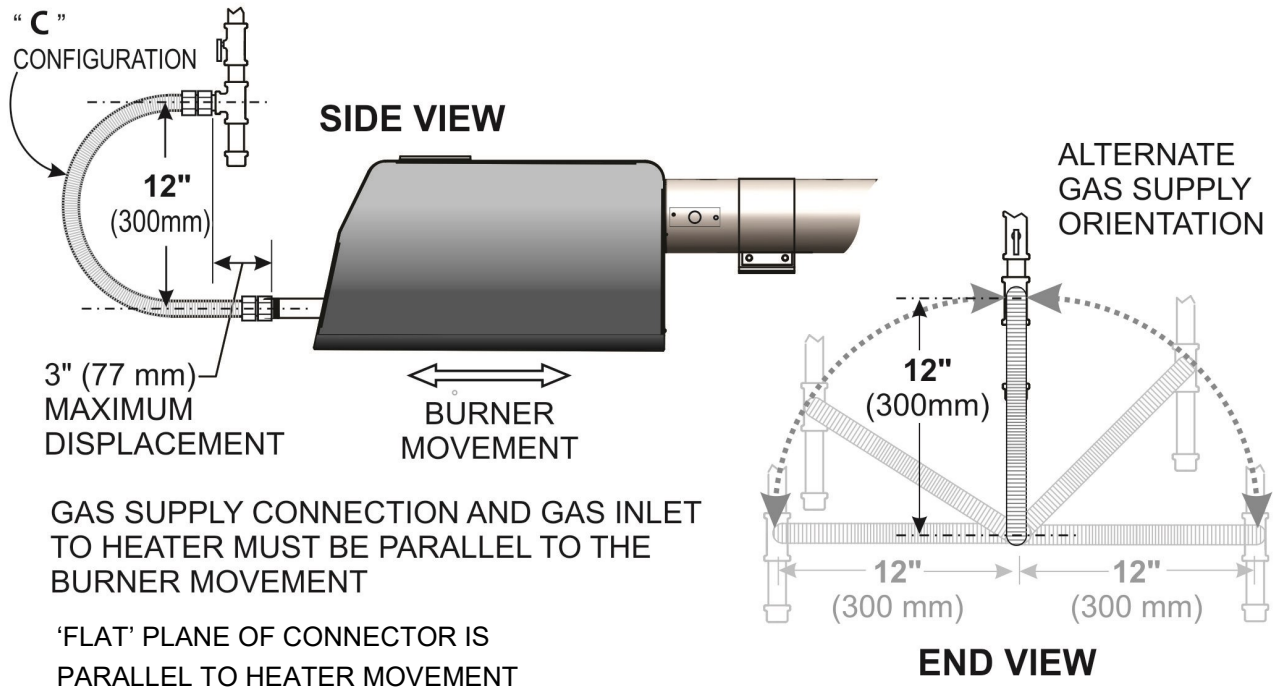
## FIGURE 18 ORIENTATION OF FLEXIBLE GAS CONNECTOR



The flexible gas connector MUST be installed in the orientation shown below as required by national installation codes and by the certification standard of this heater. This orientation protects the flexible gas connector from damage due to movement during heater expansion.

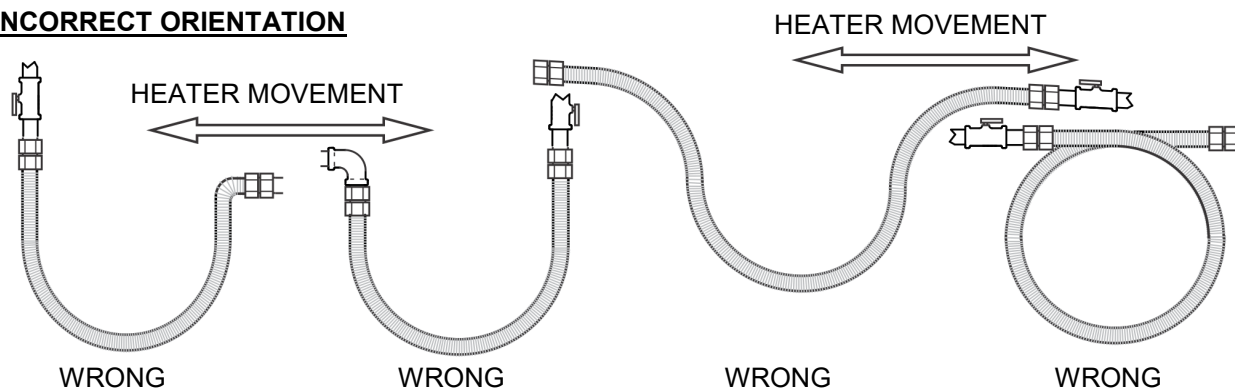
It is the responsibility of the installer to ensure correct installation of the flexible gas supply.

### CORRECT POSITIONS: GAS SUPPLY & FLEXIBLE GAS CONNECTION



**WARNING: CONNECTOR MUST BE INSTALLED IN A “C” CONFIGURATION. USE ONLY A CONNECTOR OF PROPER LENGTH AND DIAMETER. THE REQUIRED GAS CONNECTOR IS SUPPLIED WITH THE BURNER.**

### INCORRECT ORIENTATION



### 13. ELECTRICAL AND THERMOSTAT WIRING (WIRING DIAGRAMS: SEE SUPPLEMENTARY MANUAL)



The heater must be electrically grounded in accordance with the National Electrical Code. ANSI / NFPA 70 or current Canadian Electrical code CSA C22.1.

Appliance and control wiring must be in accordance with all applicable local codes. The total load of all heaters must be considered in determining the required contact rating of the controlling thermostat or switch. Each tube heater requires 120V, 60 HZ electrical power sized for 145VA. Maximum power flow for internal 24V burner components is 21VA.

The Fenwal ignition control includes a 24V/120V relay switch that provides a 45 second pre-purge and 45 second post-purge of the system. To maintain function of the post-purge feature, any **Thermostat / control must be installed in the thermostat circuit from the terminal block (TR - TW)**. A line voltage Thermostat or an "ON/OFF" control switch installed in the 120VAC power supply will disable the post-purge feature.

A maximum night set-back of 9°F (5°C) is recommended for optimum economy and comfort. To maintain satisfactory comfort levels do not turn off the heating system over night/weekends.

### 14. HIGH ALTITUDE INSTALLATIONS - *for recommended orifice sizing, and restrictions refer to the High Altitude Section in the Supplementary Manual included for this specific model*

When installed above the altitude stipulated below, the input must be de-rated by 4% for each 1000 ft above the altitude listed. Refer to the tables in Section 28 for orifice size and restrictions that apply to high altitude installation (including total system length restrictions). Check with your local utility regarding the gas supply and the de-rating of this appliance.

**USA:** The factory installed orifice for this appliance is approved for altitudes zero to 2000 feet above sea level. When installed above 2000 feet, **refer to the Supplementary Model Manual Section 15.**

**Canada:** The factory installed orifice for this appliance is approved for altitudes zero to 4500 feet above sea level. When installed above 4500 feet, **refer to the Supplementary Model Manual Section 15.**

### 15. LIGHTING INSTRUCTIONS

Refer to the lighting instructions label on the outside of the burner housing. If the unit locks out on safety, main power to the unit must be manually interrupted for a 30 second reset period before the heater can be restarted.

**NOTE:** *On initial installation, the unit may lock out on safety owing to the length of time required to bleed air from the gas piping system.*

### 16. RECOMMENDED MAINTENANCE



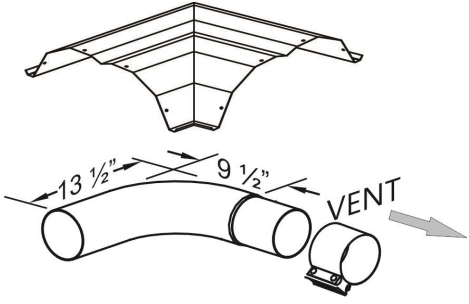

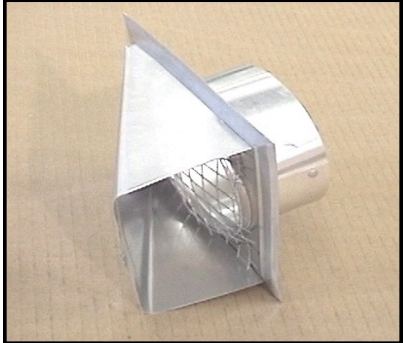
Improper adjustment, alteration, service or maintenance can cause property damage, injury or death. This heater must be installed and serviced only by a trained gas service technician.

1. Inspect the entire heater system, venting, and gas supply connections at least annually prior to the heating season. Replace worn parts and repair deficiencies.
2. Check the inlet air opening and the blower periodically, cleaning off any lint or foreign matter. It is important that the flow of combustion and ventilation air must not be obstructed.

THE TUBE HEATER BURNER IS COMPLETELY FACTORY ASSEMBLED AND TESTED. ANY ALTERATION VOIDS THE UL CERTIFICATION AND MANUFACTURER'S WARRANTY. FOR ADDITIONAL INFORMATION, CONTACT YOUR LOCAL DISTRIBUTOR OR THE MANUFACTURER.

## 17. OPTIONAL ACCESSORIES

<p><b>#2 Lion Chain</b> (115 lb work load) - <b>200 ft roll</b></p> <p><b>Safety Snap Hooks</b> - 2" - package 25- package 100</p>	<p>JL-0800-XX</p> <p>JL-0800-SH JL-0800-SH-B</p>	
<p><b>Flue Vent Terminal</b></p> <p>4" wall horizontal 6" wall horizontal</p>	<p>JA-0528-XX JA-0529-XX</p>	
<p><b>Torcrite Coupler</b></p> <p>Sufficient quantity supplied with heater</p> <p>Use for connection of vent tee, or replacement part</p> <p>NOTE: A coupler that has been in service, then loosened or removed, must be replaced.</p>	<p>JA-0516-SW</p>	

<p><b>90 degree Aluminized Steel Elbow Kit</b> (Kit includes: aluminized steel elbow, coupler, and two end plate hangers)</p> <p>For 180° elbow use two x JS-0508-SST, or use 'U'-Tube Model</p>	<p>JS-0508-SST</p>	
<p><b>Side Reflector Extension Kit-</b> 10" deep, 10 ft long Each</p>	<p>JS-0509-KT</p>	
<p><b>Fresh Air Intake Cap—Wall</b></p>	<p>JS-0532-VC</p>	
<p><b>Clearance Sign</b></p> <p>- <u>Required in some jurisdictions:</u></p> <ul style="list-style-type: none"> <li>• Vehicle service garages</li> <li>• 3/4" high red lettering on white background</li> </ul>	<p>JL-0798-CS</p>	<div style="border: 1px solid black; padding: 5px;"> <p style="text-align: center;"><b><u>WARNING</u></b></p> <p style="text-align: center;"><b>MAINTAIN ___" CLEARANCE FROM TUBE HEATER TO VEHICLES AND COMBUSTIBLE MATERIALS</b></p> </div>

**Options For Thermostat Control:**

**NOTE:** Fenwal DSI has an onboard relay switch to control the blower motor (120 Vac) and allows for heater control with either 24V or 120V thermostat.

The Fenwal DSI has a post-purge feature.

**A Thermostat MUST be installed in the heater’s thermostat circuit to enable the post-purge feature of the ignition control.**

**TruTemp Thermostat (24Vac - 3-Wire)**

True comfort control for radiant heating systems - senses and averages ambient and radiant temperatures.

Occupancy sensor with auto set-back of 9°F (5°C).

*Do not use in wet or corrosive environments*

JM-0150-XX



**Low Voltage Digital Thermostat**

(24 Volts - °F or °C selectable)

*Not for use in corrosive or wet environments*

JS-0569-WR



**Multiple Heaters** per 24V Thermostat

**Relay Switch:** One required for each burner after the first burner in a zone (1st burner connects to 24V thermostat)

Refer to wiring diagram Page 36

(field installed at or in burner)

NOTE: FENWAL DSI has built in relay for blower operation

JS-0568-CC



**Line Voltage Control:** (Interrupting power to burner *disables post-purge feature of the Fenwal ignition control*)

**Line Voltage Thermostat:**

Dual Scale: °F or °C

*Not for use in corrosive or wet environments*

JL-0772-XX



**NOTE: Fenwal DSI has an onboard relay switch to control the blower motor (120 Vac) and allows for heater control with either 24V or 120V thermostat.**

**The Fenwal DSI has a post-purge feature.**

**A Thermostat MUST be installed in the heater’s thermostat circuit to enable the post-purge feature of the ignition control.**

**A line voltage thermostat will disable the post-purge feature**

**2-Stage Low Voltage Digital Thermostat**

(24 Volts - °F or °C selectable)

*Not for use in corrosive or wet environments*

JS-0569-DT



**Moisture Proof NEMA 4X - 2-Stage Thermostat - DPDT Line Voltage**

40° - 110°F (5° - 40°C)

Both °F & °C Scales

Voltage: 24 - 277 Vac

Differential: 3°F

Stainless Steel Bulb

UL Listed

JS-0570-TT



**Modulating Low Voltage Thermostat - ZonePRO**

Temperature Control — Microprocessor-optimized PIA

Temperature Setting — Manual — °C or °F

Dimensions (HxWxD) — 2.7 x 4.6 x 1.0 in

Setpoint Range — 50° F to 95° F (10° C to 35° C)

Temperature Display — 32° F to 140° F (0° C to 60° C)

Auto Changeover Deadband — 9° F (5° C)

Mode Hysteresis — 4° F (2° C)

JS-0569-MT





**FOR GAS-FIRED INFRA-RED LOW INTENSITY TUBE HEATERS: SST / IST SERIES**

The Manufacturer warrants that this product is free from defects in material or workmanship under normal use and service subject to the terms of this document.

**THREE YEAR WARRANTY**

Subject to the conditions and limitations stated herein, during the term of this limited warranty, we will supply any component part (at our option a new or repaired component part) of the heater as defined below, excluding any labor, which the Manufacturer's examination determines to be defective in workmanship or material for a period of three years (3 years) from the date of installation, unless otherwise specified below. This warranty applies to the heater's original owner, and subsequent transferees and only if the unit is installed and operated in accordance with the printed instructions accompanying the unit and in compliance with all applicable installation codes and good trade practices. Warranty is only applicable to Schwank components, other parts are limited to their own Manufacturers warranty period of one year (1 year).

**TEN YEAR WARRANTY**

The Manufacturer warrants the burner cup sub-assembly, and the radiating tubes (excluding couplings) for a period of ten years (10 years).

**WHAT IS NOT COVERED**

The Manufacturer shall not be responsible for any expenses, including service, labor, diagnosis, analysis, material or transportation charges incurred during removal or reinstallation of this product, or any of its components or parts. All labor or service charges shall be paid by the owner. This warranty does not cover heating products improperly installed, misused, exposed to or damaged by negligence, accident, corrosive or contaminating atmosphere, water, excessive thermal shock, impact, abrasion, normal wear due to use, alteration or operation contrary to the owner's manual or if the serial number has been altered, defaced or removed. This warranty shall not apply if the input to the heating product exceeds by more than 2% of the rated input on the rating plate. The Manufacturer shall not be liable for any default or delay in performance by its warranty caused by any contingency beyond its control, including war, government restrictions, or restraints, strikes, fire, flood, acts of God, or short or reduced supply of raw materials or products.

**WARRANTY PROCEDURE**

To establish the installation date for any purpose under this Limited Warranty, you must retain the original records that can establish the installation date of your unit. If you do not provide such documents, the start date of the term of this Limited Warranty will be based upon the date of unit manufacture, plus thirty (30) days. Failure to maintain the equipment through regular annual service maintenance by a qualified service technician shall void the warranty.

**LIMITATIONS AND EXCLUSIONS**

This document contains all warranties made by the Manufacturer and may not be varied, altered or extended by any person. There are no promises, or agreements extending from the Manufacture other than the statements contained herein. THIS WARRANTY IS IN LIEU OF ALL WARRANTIES EXPRESSED OR IMPLIED, TO THE EXTENT AUTHORIZED BY THE LAWS OF THE JURISDICTION, INCLUDING SPECIFICALLY THE WARRANTIES OR MERCHANTABILITY OF FITNESS FOR A PARTICULAR PURPOSE.

It is understood and agreed that the Manufacturer's obligation hereunder is limited to repairing or replacing parts determined to be defective as stated above. In no event shall the Manufacturer be responsible for any alleged personal injuries or other special, incidental or consequential damages. As to property damages, contract, tort or other claim the Manufacturer's responsibility shall not exceed the purchase price paid for the product.

All replacement parts will be warranted for the unused portion of the warranty coverage period remaining on the applicable unit.

Some Authorities do not allow certain warranty exclusions or limitations on duration of warranty or the exclusions or limitations of incidental or consequential damages. In such cases, the above limitations or exclusions may not apply to you and are not intended to do so where prohibited by law. This warranty gives you specific legal rights. You may also have other rights which vary by jurisdiction.

**SCHWANK GROUP**  
**2 SCHWANK WAY, WAYNESBORO, GEORGIA. 30830**  
**5285 BRADCO BLVD. MISSISSAUGA, ON, L4W 2A6**  
**Ph: 1-877-446-3727 Fax: 1-866-361-0523**  
**www.SchwankGroup.com www.InfraSave.com**