

Installation Instructions

LINK-C

DEADBREAK CAM LINK OPERABLE CONNECTOR SYSTEM

The Link is a 600 amp, connector designed to: 1.) provide a fully shielded, fully submersible hot stick operable connection between the cable and the apparatus. 2.) provide 200 ampere tap, for 15kV and 25kV.

WARNING: The following ratings apply to this product:

- 600 Ampere Deadbreak Interface** – 600 or amperes load current and 25,000 amperes short circuit current for 10 cycles.
- 200 Ampere Loadbreak Interface** – 200 amperes load current and 10,000 amperes fault–close current. For higher short circuit current: 1) this interface should only be operated de–energized; and 2) elbows used for taps or grounding must be adequately secured such as with a bail.

DANGER

All apparatus must be de-energized during installation or removal of part(s). For loadbreak products follow operating instructions. All deadbreak connectors must be de-energized before operating. All 200A deadbreak connectors must be mechanically secured with bails when connected.

All apparatus must be installed and operated in accordance with individual user, local, and national work rules. These instructions do not attempt to provide for every possible contingency.

Do not touch or move energized products.

Excess distortion of the assembled product may result in its failure.

FOR MORE INFORMATION ON PARTS, INSTALLATION RATINGS AND COMPATIBILITY, CALL THE NEAREST ELASTIMOLD OFFICE.

Inspect parts for damage, rating and compatibility with mating parts.

This product should be installed only by competent personnel trained in good safety practices involving high voltage electrical equipment. These instructions are not intended as a substitute for adequate training or experience in such safety practices.

Failure to follow these instructions will result in damage to the product and serious or fatal injury.

If this product is supplied with a protective shipping cover(s), remove this shipping cover(s) and replace with the appropriate HV insulated cap(s) or connector(s) before submerging or energizing the circuit.

IMPORTANT

1. Check contents of package to ensure they are complete and undamaged.
2. Check all components to ensure proper fit with cable and/or mating products.
3. Read entire installation instructions before starting.
4. Have all required tools at hand and maintain cleanliness throughout the procedure.

STEP 1

Install the 600 amp elbow onto the cable according to the installation instructions supplied with the elbow, such that it will align with the stand–off plug.

STEP 2

Determine which mounting type you will be installing.

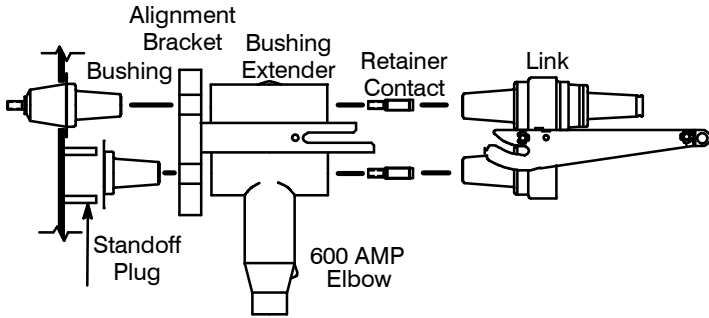

Welded Stud (3)
 For SOP

**ALIGNMENT BRACKET WITH
 BOLTED STAND-OFF PLUG
 PROCEED TO STEP 3**

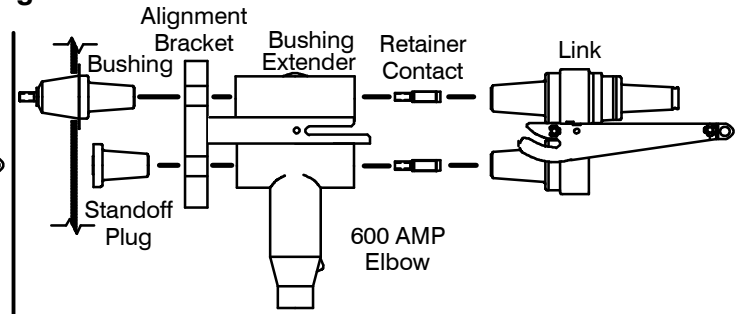

**ALIGNMENT BRACKET
 PROCEED TO STEP 4**

IF RETROFITTING FROM STICK-OP OR BOLTED LINK PROCEED TO RETROFIT SUPPLEMENT PAGE 7.

STEP 3 MOUNTED STAND-OFF PLUG INSTALLATION (Where Applicable)

1. Weld studs to faceplate per customer standard practice to dimensions shown. Studs to be 3/8-16 x 2" long.
2. Check prepack for the following: 6 hex nuts and 3 lockwashers.
3. Install the 3 hex nuts onto the 3 studs per the dimensions indicated or use (3) spacers (not supplied).
IMPORTANT: The 3 hex nuts are needed to support the stand-off plug so that it is in-line with the bushing. These supports (nuts) may not be needed if the bushing in your application are welded Elastimold bushings.
4. Install SOP over the 3 studs and resting on the nuts or spacers.
5. **IMPORTANT:** Install lockwasher and hex nut on each of the 3 studs and tighten to 12 foot lbs torque. The top surfaces of the bushing and stand-off plug must be in-line, if not re-adjust the nuts as required.

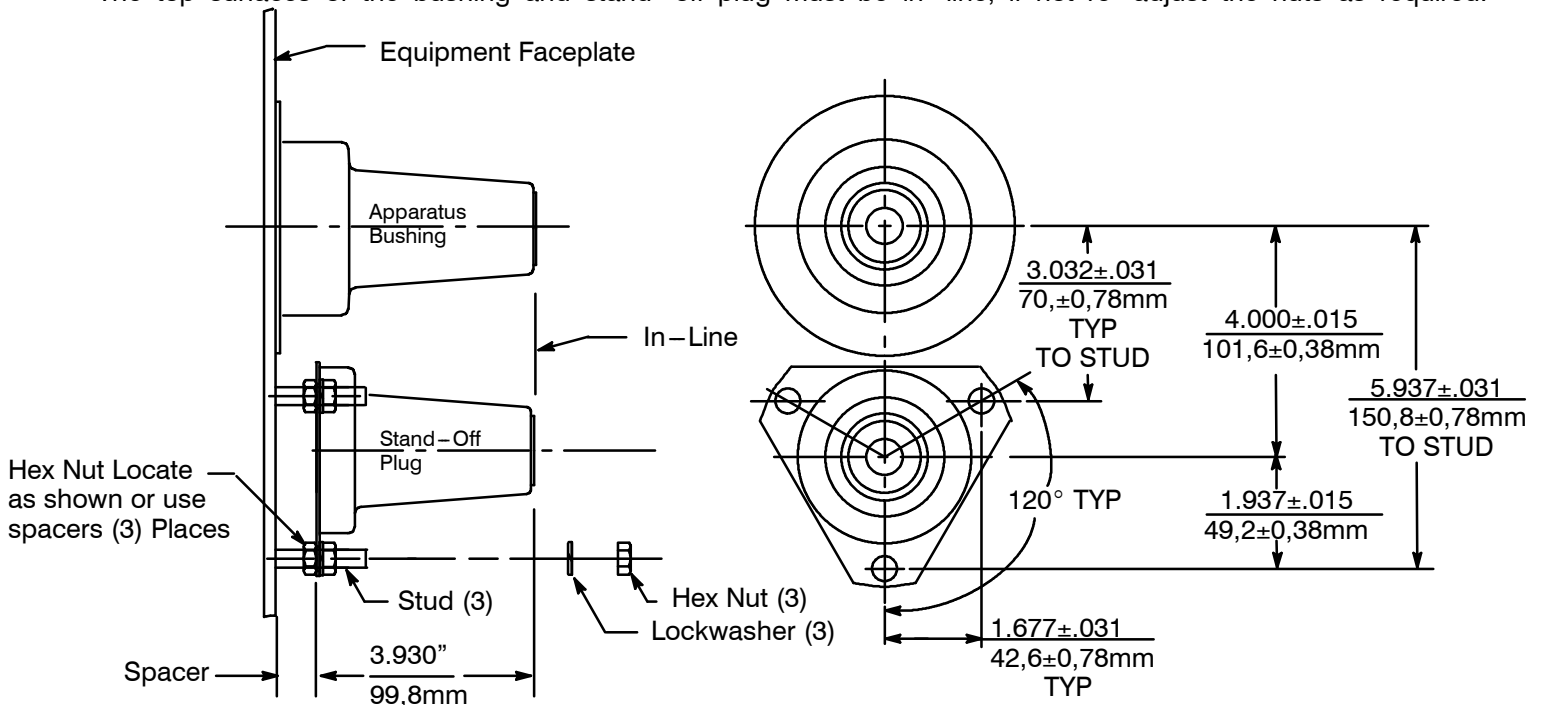

STEP 4

1. Clean and lubricate the apparatus bushing and both interfaces of the 600 amp bushing extender with ELASTIMOLD supplied lubricant. **IMPORTANT:** Bushing extender interfaces must be thoroughly lubricated to allow for proper removal of the link.
2. Install bushing extender onto the apparatus bushing. Insert the 600ATM into the retainer contact and engage the internal hex broach.
3. Insert the retainer contact into the bushing extender and thread into apparatus bushing using a suitable tool applied to the 1" hex portion of the 600ATM, torque to 50-60 ft-lbs.
4. Clean and lubricate the epoxy standoff plug and both interfaces of the 600 amp elbow with ELASTIMOLD supplied lubricant. **IMPORTANT:** Elbow interfaces must be thoroughly lubricated to allow for proper removal of the link.
5. Install the elbow onto the epoxy standoff plug. Insert the 600AMT into the retainer contact and engage the internal hex broach.
6. Insert the retainer contact into the 600 amp elbow through the hole in the compression lug and thread into the epoxy standoff plug using a suitable tool applied to the 1" hex portion of the 600AMT, torque to 50-60 ft-lbs.

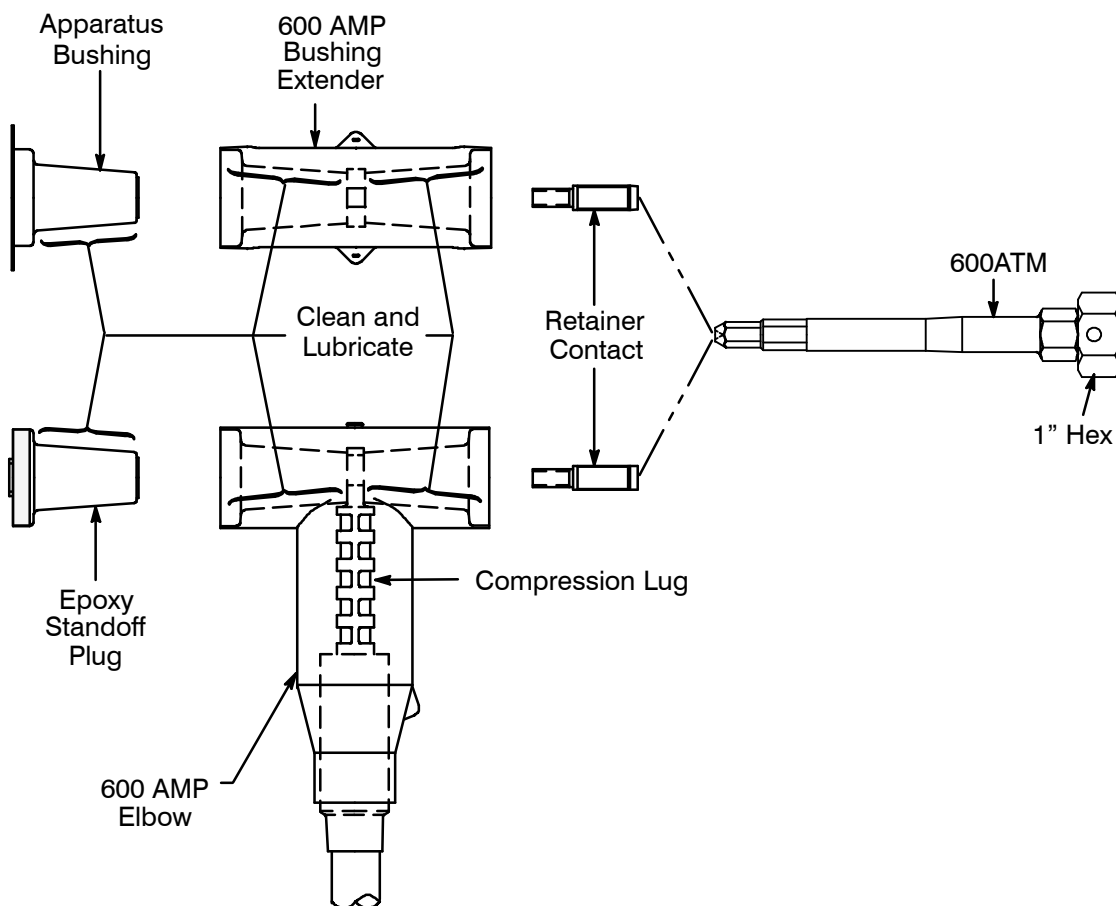

STEP 5 - ALIGNMENT BRACKET INSTALLATION

1. Remove the bushing extender clamp and elbow clamp from alignment bracket.
2. Position the alignment bracket on bushing extender to a dimension of $2\frac{1}{2}$ " (63.5mm) from grounding eye.
3. Assemble bushing extender clamp to the alignment bracket with hardware supplied and torque by alternating sides until clamp tabs are flush with each other and tight on both sides.

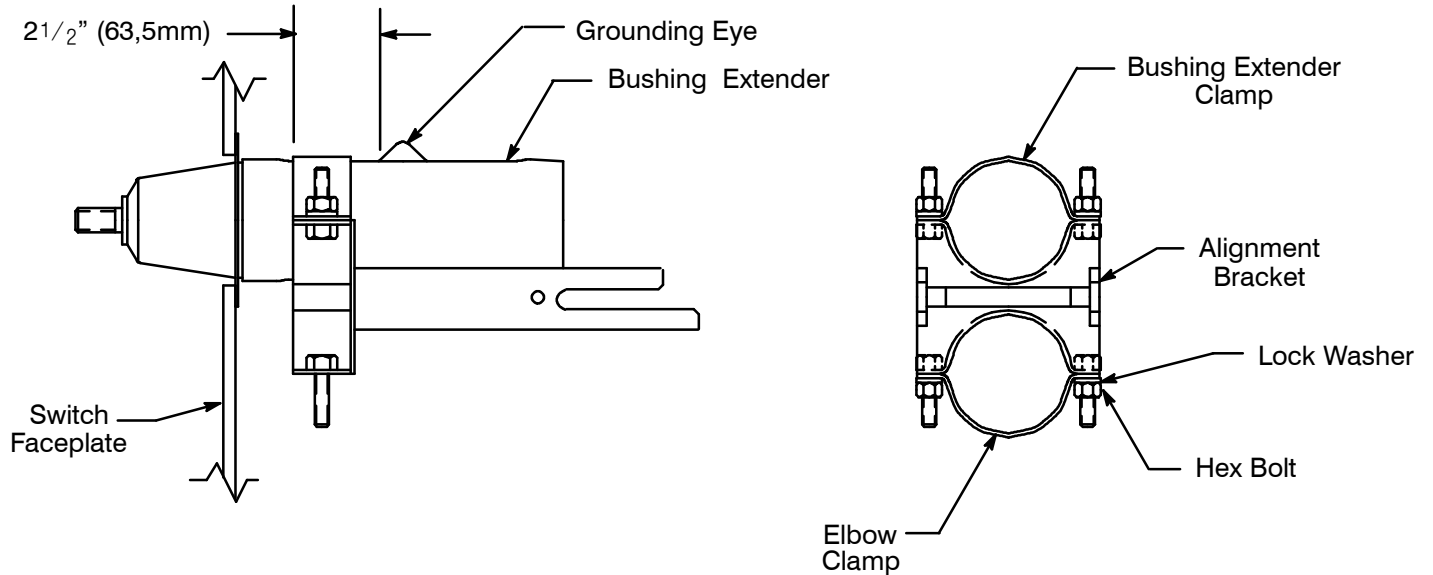

STEP 6

IMPORTANT:

Position the elbow in the alignment bracket such that the elbow cuff is lined up evenly with the bushing extender cuff.

Assemble the elbow clamp to the alignment bracket with hardware supplied and torque by alternating sides until clamp tabs are flush with each other and tight on both sides.

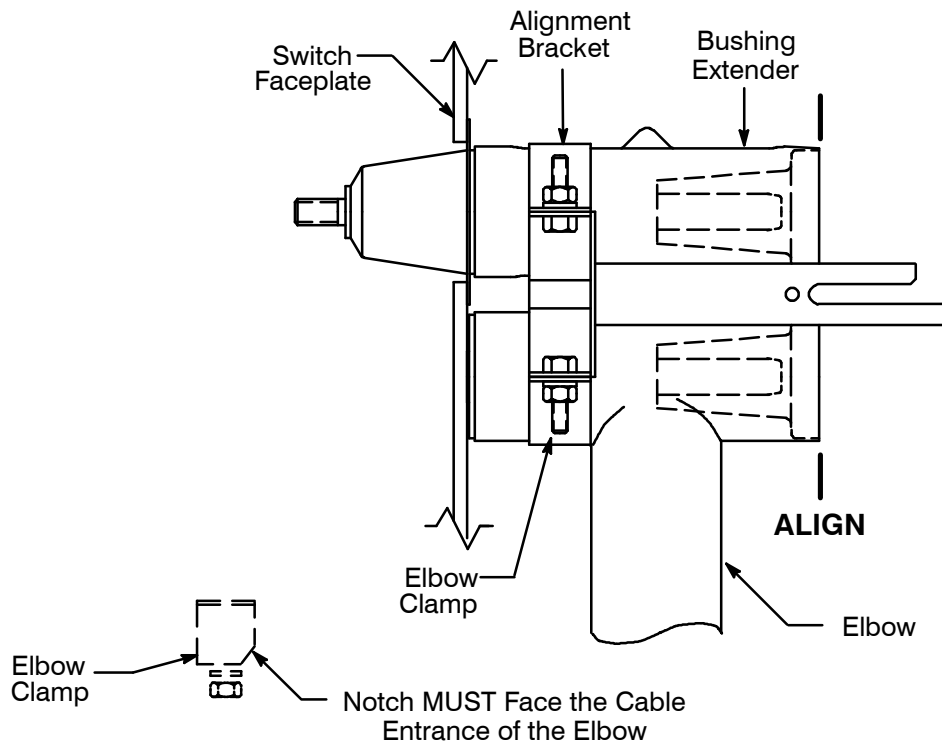

STEP 7

1. Clean and lubricate both 600 ampere interfaces of the Link with ELASTIMOLD supplied lubricant.
IMPORTANT: Interfaces must be thoroughly lubricated to allow for proper removal of the link.

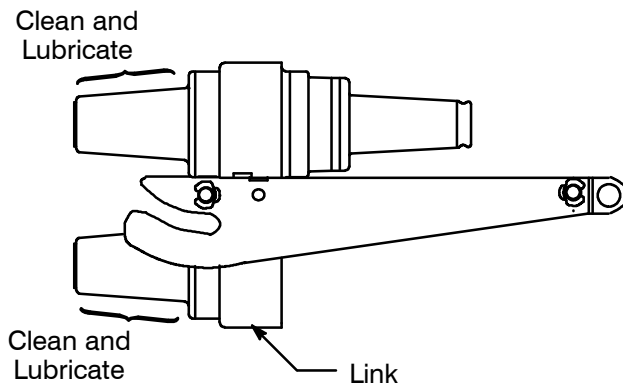

2. Align the Link such that when inserted into the bushing extender and elbow the Link is perpendicular to the switch faceplate.

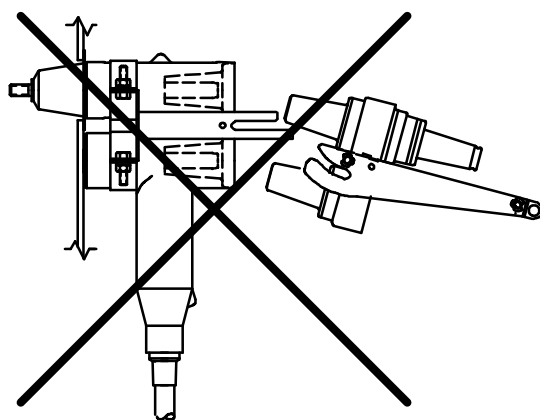

3. Insert the link into the bushing extender and elbow making sure both lever arms are on the inside of the alignment bracket legs.
4. Engage the pivot pin into the slots in the alignment bracket legs. While pushing inward, move the lever arms downward by use of the hot stick eye thus engaging the roller pin and moving the link inward. Continue moving lever arms until perpendicular to the alignment bracket leg.

TOP VIEW

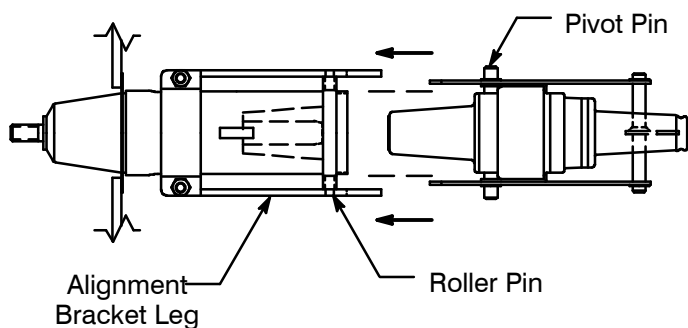

SIDE VIEW

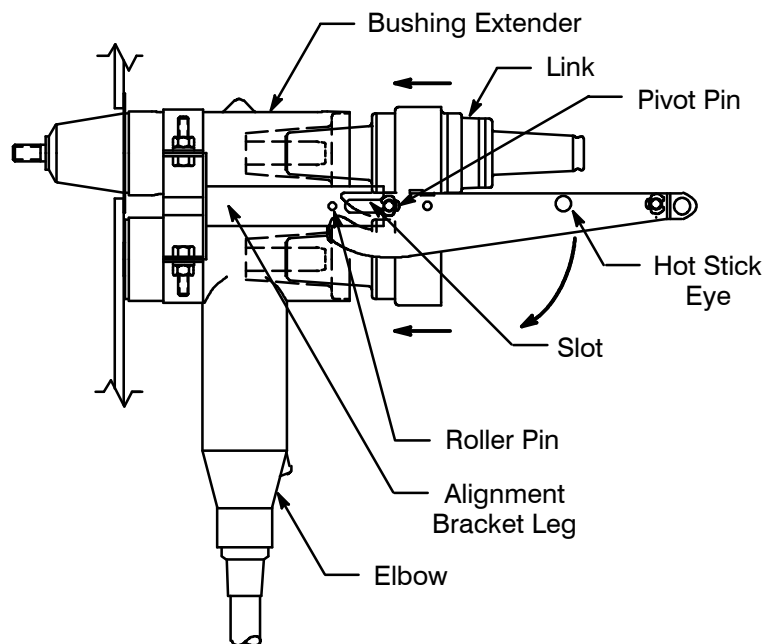

STEP 8

1. The elbow must be grounded. Feed a #14 AWG or #12 AWG solid copper wire through the grounding eye on the elbow, twist tight and connect to ground.
2. Clean and lubricate the 200 amp interface on the Link.
3. Ground, then install the desired mating product on the 200 amp interface per the installation instructions supplied with the mating product.
4. The cable must be grounded:
 - if concentric neutral cable is used, twist the concentric neutral wires together and connect to ground using an appropriate connector.
 - if 20MA or 21MA grounding devices are used, connect the ground lead from the 20/21MA device to ground using a suitable connector.

For three-phase installations all grounds from all three phases must be tied to a common ground point.

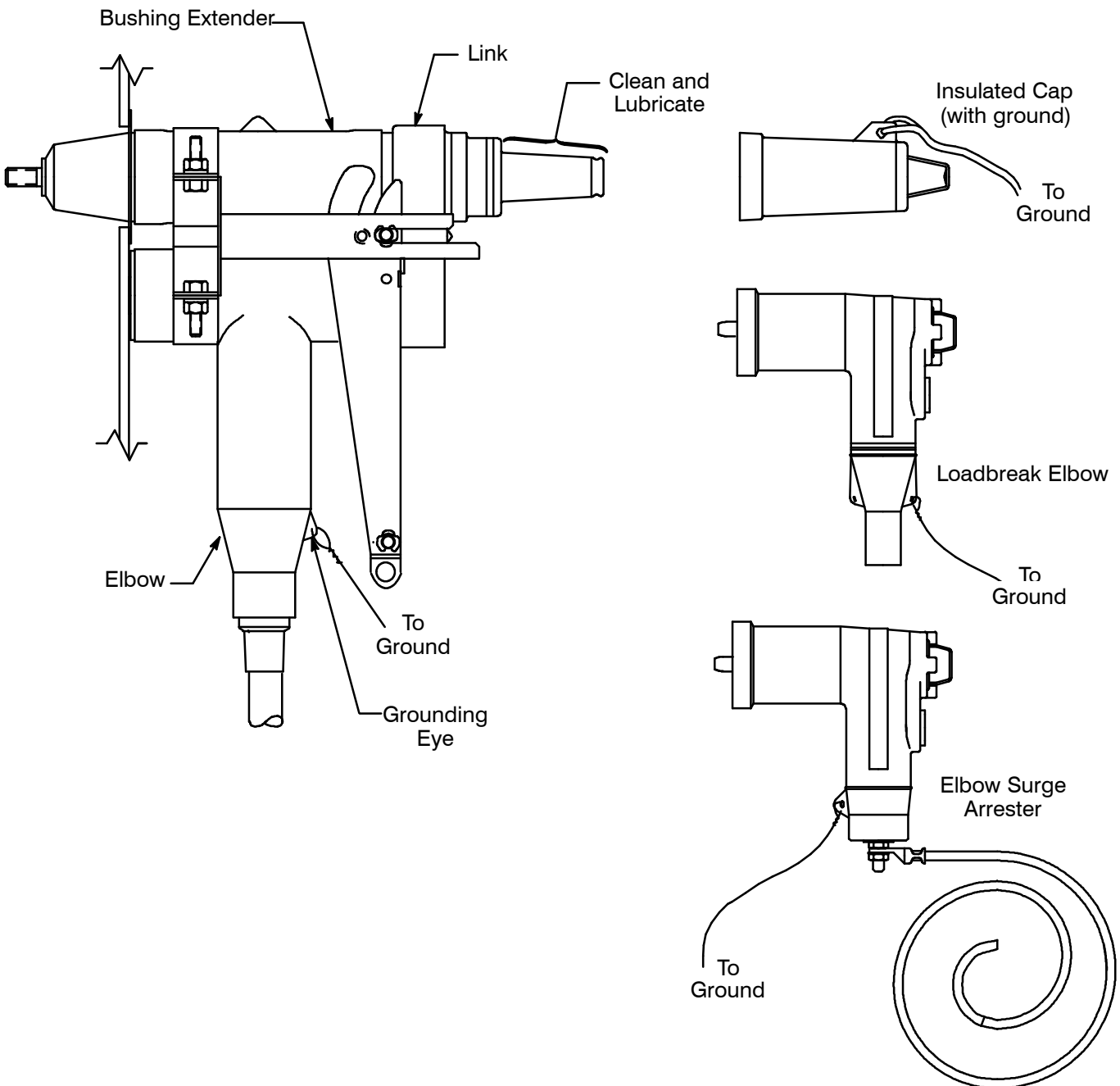

STEP 9

For operation of the Link and 200 ampere mating products, refer to the applicable operating instructions.

RETROFIT SUPPLEMENT

FROM STICK-OP TO CAM LINK

STEP A

Remove elbow from bushing. Remove the LRTP from the elbow using a 650 ET (extracting tool) following the instructions supplied with the tool.

STEP B

1. Using the 600ATM, engage the internal hex of the plastic nose on the retro-fit sleeve assembly.
2. Guide the plastic nose through the threaded hole in the compression lug inside the 600 amp elbow and engage the threads on the retro-fit sleeve. **IMPORTANT:** Retro-fit sleeve assembly must be installed into the elbow on the side opposite the apparatus.
3. Hand tighten the retro-fit sleeve into the compression lug until fully seated. **Take care not to crossthread the retro-fit sleeve.**
4. Push the plastic nose out the apparatus side of the 600 amp elbow. Discard plastic nose.

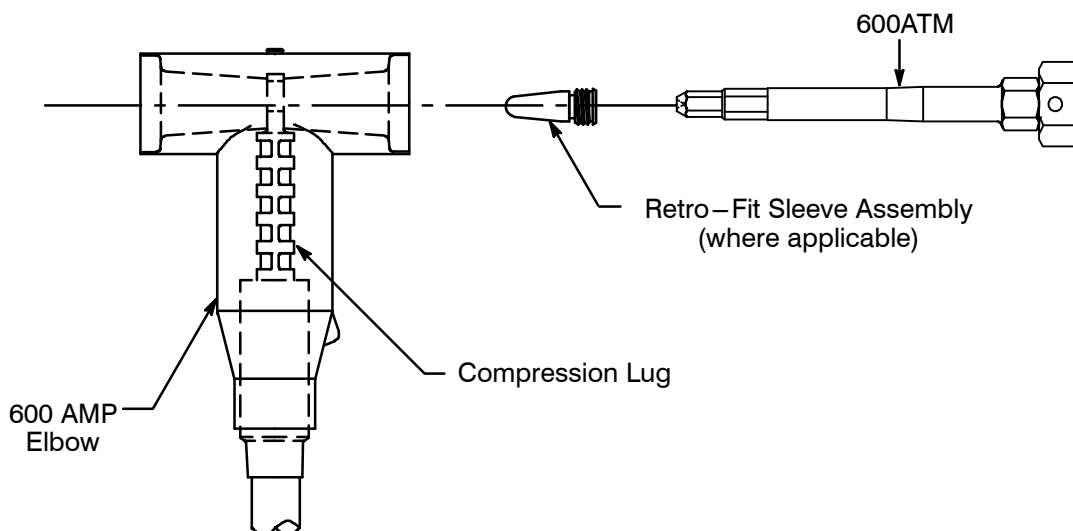

PROCEED TO STEP 4

FROM BOLTED LINK TO CAM LINK

STEP A

Using a hot stick, remove the mating 200 amp products from the Link, exposing the 200 amp interfaces.

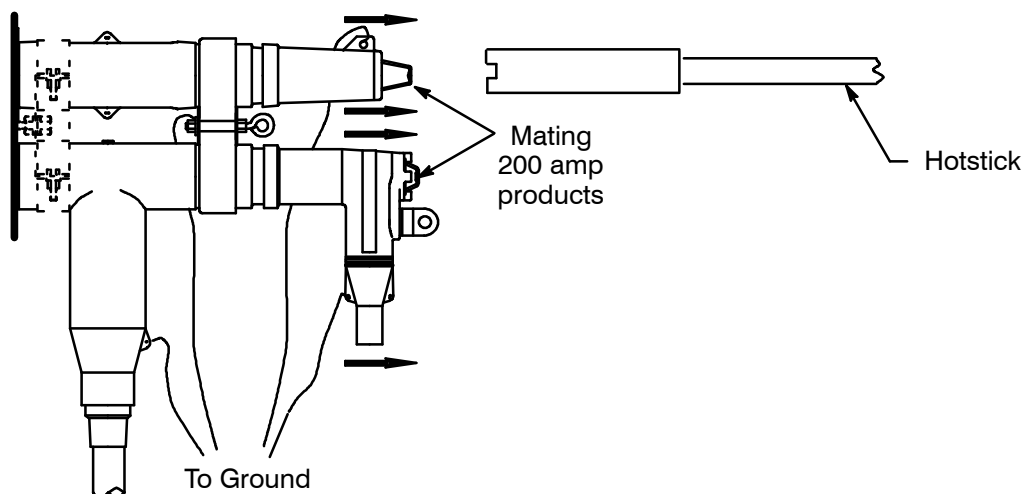

STEP B

Using approved test apparatus or a 370TR test rod (in conjunction with an appropriate meter) test each elbow tap plug to insure that the conductor system is de-energized.

IMPORTANT: Follow established utility procedures for keeping all potentially live test areas clear of ground until the system is tested de-energized. If the system is energized, do not continue. See DANGER and IMPORTANT comments on front page.

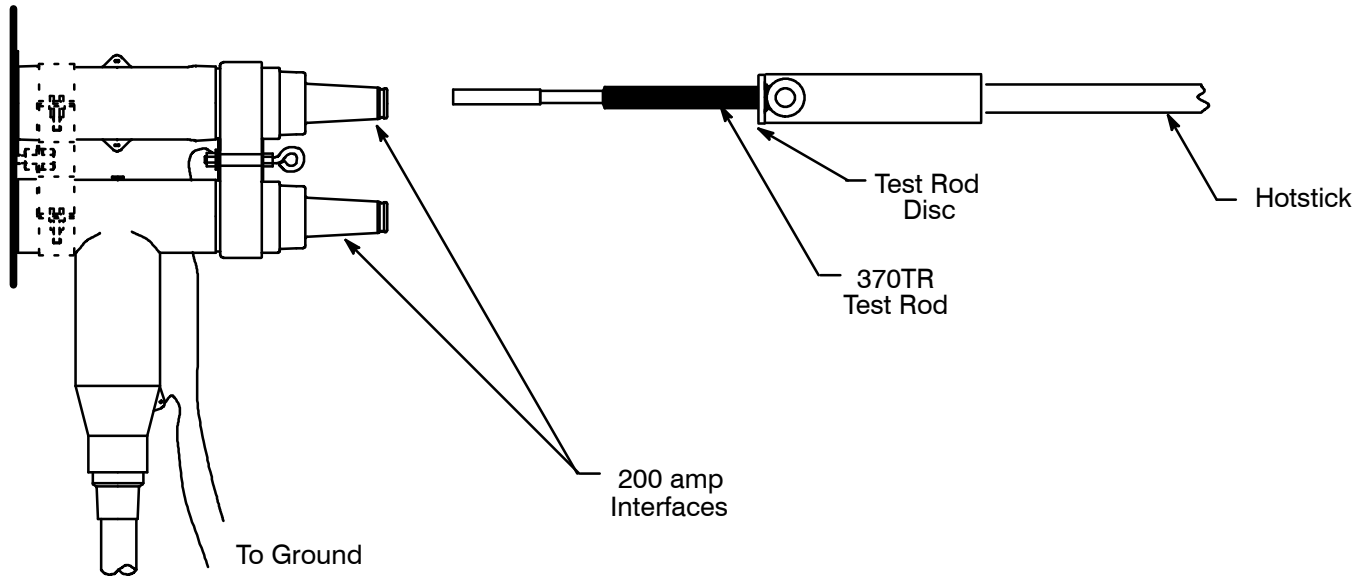

STEP C

1. Clean and lubricate the GLR, grounding elbow, interfaces with ELASTIMOLD supplied lubricant.
2. Connect the leads on the GLR, grounding elbow, to ground. Using the hotstick install a GLR onto either 200 amp interfaces of the Link until fully seated (This will ensure the system is de-energized). Remove the grounding elbow.

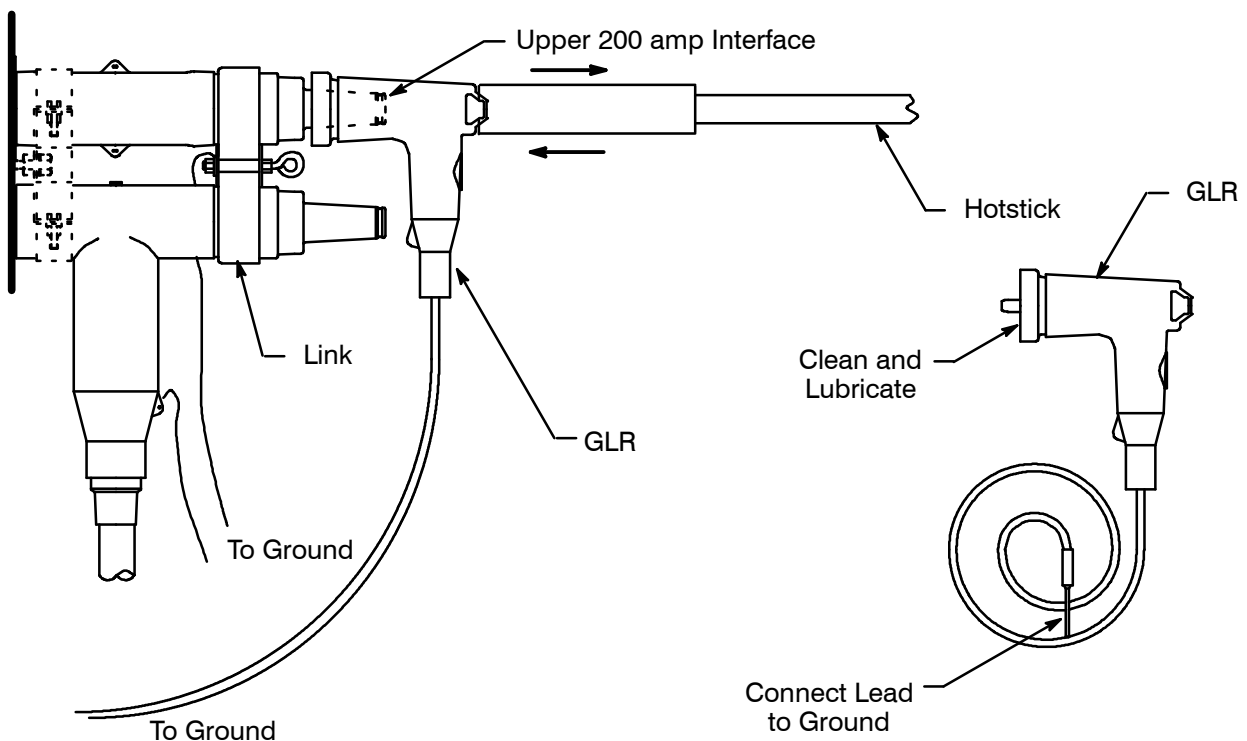

STEP D

Using torque/socket wrench and a 600ATM, Operating Tool, and insert into the top 200 amp interface to engage the internal bolt. Turn in a counter clockwise direction, approximately 13-15 turns, to fully disengage threads. Remove the 600ATM from interface.

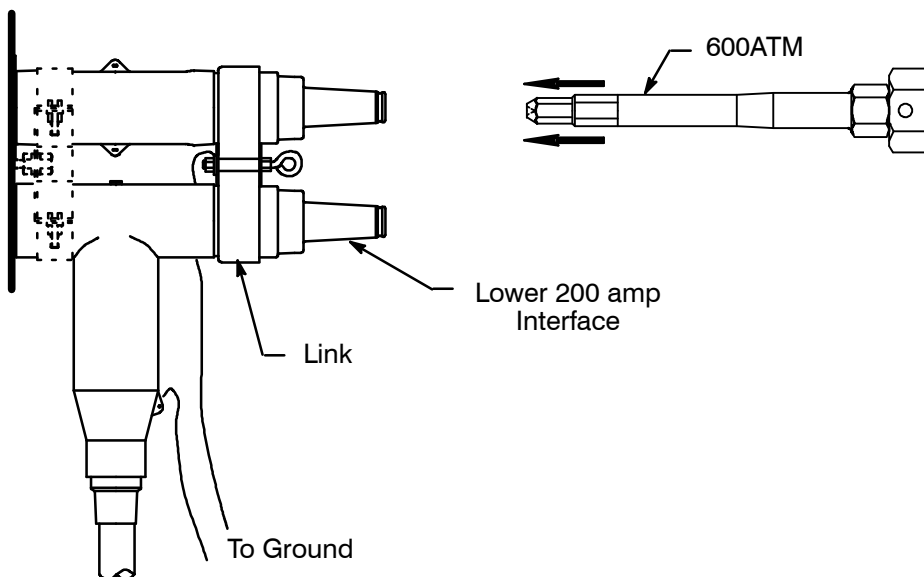

STEP E

Repeat STEP D on lower 200 amp interface.

STEP F

Attach the hotstick to the eyebolt of the link bracket. Pull on the hotstick, at approximately 30° off of the two 200 amp interfaces to remove link from bushing extender and elbow. Once removed, disconnect the ground lead from the Link.

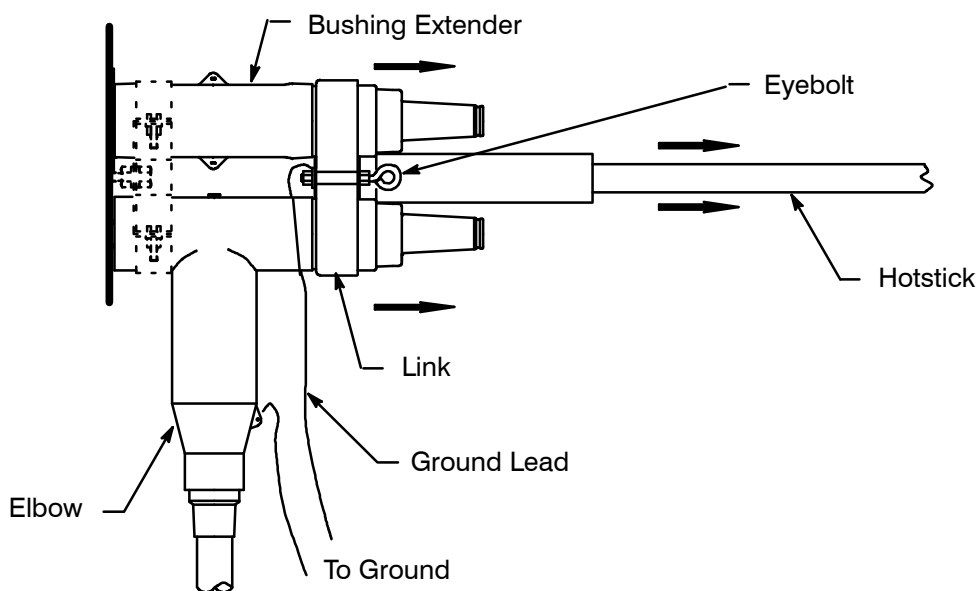

STEP G

1. Insert the 600ATM into the hex in the retainer sleeve in the bushing extender. Using the 1" hex portion of the 600ATM unscrew the retainer sleeve.
2. Repeat STEP G 1 for the elbow retainer sleeve.

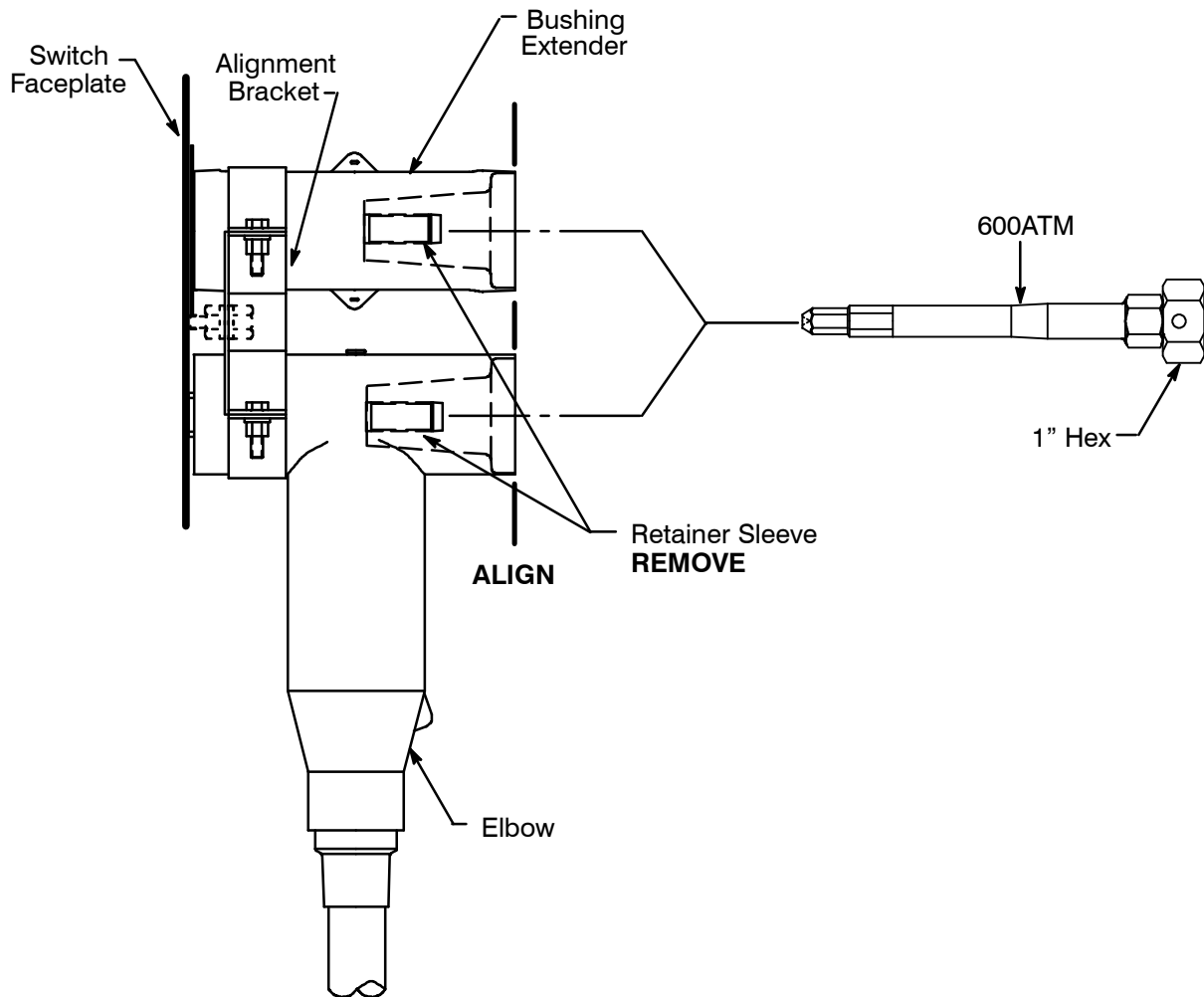

STEP H

Remove the alignment bracket

PROCEED TO STEP 4 of LINK-C Instructions.

Thomas & Betts

8155 T&B Boulevard, Memphis, Tennessee
38125 (800) 888-0211 Fax: (800) 888-0690