

AIR CONDITIONER

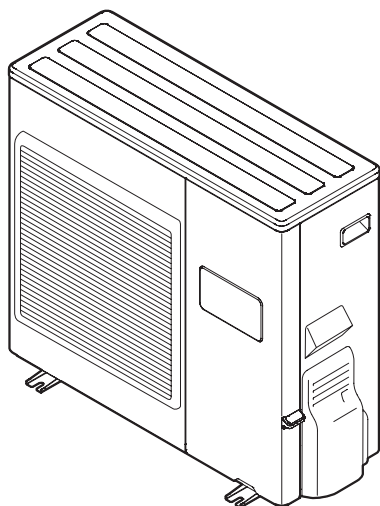

INSTALLATION MANUAL

OUTDOOR UNIT

For authorized service personnel only.

English

MANUEL D'INSTALLATION

APPAREIL EXTÉRIEUR

Pour le personnel d'entretien autorisé uniquement.

Français

MANUAL DE INSTALACIÓN

UNIDAD EXTERIOR

Únicamente para personal de servicio autorizado.

Español



PART No. 9374995592

INSTALLATION MANUAL

PART No. 9374995592
OUTDOOR UNIT

Contents

1. SAFETY PRECAUTIONS.....	2
1.1. IMPORTANT! Please read before starting.....	2
1.2. Special precautions.....	2
2. ABOUT THIS PRODUCT.....	3
2.1. Precautions for using R410A refrigerant.....	3
2.2. Special tools for R410A refrigerant.....	3
2.3. Accessories.....	3
2.4. Operating range.....	3
3. GENERAL SPECIFICATION.....	4
3.1. Selecting circuit breaker and wiring.....	4
3.2. Selecting the pipe material.....	4
3.3. Connection pipe requirement.....	4
3.4. Additional charging.....	4
4. INSTALLATION WORK.....	4
4.1. Selecting an installation location.....	4
4.2. Installation dimensions.....	4
4.3. Transporting the unit.....	5
4.4. Drain installation.....	6
4.5. Secure the unit.....	6
5. PIPE INSTALLATION.....	6
5.1. Brazing.....	6
5.2. Flare connection (pipe connection).....	6
5.3. Sealing test.....	7
5.4. Vacuum process.....	7
5.5. Additional charge.....	8
5.6. Gas leakage inspection.....	8
6. ELECTRICAL WIRING.....	8
6.1. Notes for electrical wiring.....	8
7. TEST RUN.....	9
8. PUMP DOWN.....	10

NOTES: This manual describes how to install the air conditioner described above. Handling and installation shall only be done by professionals as outlined in this manual.

- Installation must be performed in accordance with the requirement of NEC (National Electrical Code) and CEC (Canadian Electrical Code) by authorized personnel only.
- All products are manufactured to metric units and tolerances. United States customary units are provided for reference only. In cases where exact dimensions and tolerances are required, always refer to metric units.

1. SAFETY PRECAUTIONS

1.1. IMPORTANT! Please read before starting

This air conditioning system meets strict safety and operating standards. As the installer or service person, it is an important part of your job to install or service the system so it operates safely and efficiently.

For safe installation and trouble-free operation, you must:

- Carefully read this instruction booklet before beginning.
- Follow each installation or repair step exactly as shown.
- Observe all local, state, and national electrical codes.
- Pay close attention to all warning and caution notices given in this manual.

WARNING: This symbol refers to a hazard or unsafe practice which can result in severe personal injury or death.

CAUTION: This symbol refers to a hazard or unsafe practice which can result in personal injury and the potential for product or property damage.

• Hazard alerting symbols



: Electrical



: Safety/alert

If Necessary, Get Help

These instructions are all you need for most installation sites and maintenance conditions. If you require help for a special problem, contact our sales/service outlet or your certified dealer for additional instructions.

In Case of Improper Installation

The manufacturer shall in no way be responsible for improper installation or maintenance service, including failure to follow the instructions in this document.

1.2. Special precautions

When Wiring

ELECTRICAL SHOCK CAN CAUSE SEVERE PERSONAL INJURY OR DEATH. ONLY A QUALIFIED, EXPERIENCED ELECTRICIAN SHOULD ATTEMPT TO WIRE THIS SYSTEM.

- Do not supply power to the unit until all wiring and tubing are completed or reconnected and checked.
- Highly dangerous electrical voltages are used in this system. Carefully refer to the wiring diagram and these instructions when wiring. Improper connections and inadequate earthing (grounding) can cause accidental injury or death.
- Earth (Ground) the unit following local electrical codes.
- Connect all wiring tightly. Loose wiring may cause overheating at connection points and a possible fire hazard.

When Transporting

Be careful when picking up and moving the indoor and outdoor units. Get a partner to help, and bend your knees when lifting to reduce strain on your back. Sharp edges or thin aluminum fins on the air conditioner can cut your fingers.

When Installing...

...In a Ceiling or Wall

Make sure the ceiling/wall is strong enough to hold the unit's weight. It may be necessary to construct a strong wood or metal frame to provide added support.

...In a Room

Properly insulate any tubing run inside a room to prevent "sweating" that can cause dripping and water damage to walls and floors.

...In Moist or Uneven Locations

Use a raised concrete pad or concrete blocks to provide a solid, level foundation for the outdoor unit. This prevents water damage and abnormal vibration.

...In an Area with High Winds

Securely anchor the outdoor unit down with bolts and a metal frame. Provide a suitable air baffle.

...In a Snowy Area (for Heat Pump-type Systems)

Install the outdoor unit on a raised platform that is higher than drifting snow.

When Connecting Refrigerant Tubing

- Keep all tubing runs as short as possible.
- Use the flare method for connecting tubing.
- Apply refrigerant lubricant to the matching surfaces of the flare and union tubes before connecting them, then tighten the nut with a torque wrench for a leak-free connection.
- Check carefully for leaks before opening the refrigerant valves.

NOTES:

Depending on the system type, liquid and gas lines may be either narrow or wide. Therefore, to avoid confusion the refrigerant tubing for your particular model is specified as either "small" or "large" rather than as "liquid" or "gas".

When Servicing

- Turn the power OFF at the main circuit breaker panel before opening the unit to check or repair electrical parts and wiring.
- Keep your fingers and clothing away from any moving parts.
- Clean up the site after you finish, remembering to check that no metal scraps or bits of wiring have been left inside the unit being serviced.
- After installation, explain correct operation to the customer, using the operating manual.

⚠ WARNING

Never touch electrical components immediately after the power supply has been turned off. Electrical shock may occur. After turning off the power, always wait 10 minutes or more before touching electrical components.

- Be sure to read this manual thoroughly before installation.
- The warnings and precautions indicated in this Manual contain important information pertaining to your safety. Be sure to observe them.
- Hand this Manual, together with the operating manual, to the customer. Request the customer to keep them on hand for future use, such as for relocating or repairing the unit.

⚠ WARNING

- Installation of this product must be done by experienced service technicians or professional installers only in accordance with this manual. Installation by non-professional or improper installation of the product may cause serious accidents such as injury, water leakage, electric shock, or fire. If the outdoor unit is installed in disregard of the instructions in the installation manual, it will void the manufacturer's warranty.
- Do not turn on the power until all work has been completed. Turning on the power before the work is completed can cause serious accidents such as electric shock or fire.
- If refrigerant leaks when you are working, ventilate the area. If the leaking refrigerant is exposed to a direct flame, it may produce a toxic gas.
- Installation work must be performed in accordance with regulations, codes, or standards for electrical wiring and equipment in each country, region, or the installing place.
- Do not use this equipment with air or any other unspecified refrigerant in the refrigerant lines. Excess pressure can cause a rupture.
- During installation, make sure that the refrigerant pipe is attached firmly before you run the compressor. Do not operate the compressor under the condition of refrigerant piping not attached properly with 3-way valve open. This may cause abnormal pressure in the refrigeration cycle that leads to rupture and even injury.
- When installing and relocating the air conditioner, do not mix gases other than the specified refrigerant (R410A) to enter the refrigerant cycle. If air or other gas enters the refrigerant cycle, the pressure inside the cycle will rise to an abnormally high value and cause rupture, injury, etc.
- For the air conditioner to work appropriately, install it as written in this manual.

- To connect the indoor unit and outdoor unit, use air conditioner piping and cables available locally as standard parts. This manual describes proper connections using such installation set.
- If the supply cord is damaged, it must be replaced by the manufacturer, its service agent or similarly qualified persons in order to avoid a hazard.
- Do not use an extension cable.
- Do not modify power cable, use extension cable or branch wiring. Improper use may cause electric shock or fire by poor connection, insufficient insulation or over current.
- Do not purge the air with refrigerants but use a vacuum pump to vacuum the installation.
- There is no extra refrigerant in the outdoor unit for air purging.
- Do not use means to accelerate the defrosting process or to clean, other than those recommended by the manufacturer.
- The appliance shall be stored in a room without continuously operating ignition sources (for example: open flames, an operating gas appliance or an operating electric heater.)
- Using the same vacuum pump for different refrigerants may damage the vacuum pump or the unit.
- Use a clean gauge manifold, vacuum pump and charging hose for R410A exclusively.
- Do not modify this unit, such as opening a hole in the cabinet.
- During the pump-down operation, make sure that the compressor is turned off before you remove the refrigerant piping. Do not remove the connection pipe while the compressor is in operation with 2-way or 3-way valves open. This may cause abnormal pressure in the refrigeration cycle that leads to rupture and even injury.
- Dispose of the packing materials safely. Tear and dispose of the plastic packing bags so that children cannot play with them. There is the danger of suffocation if children play with the original plastic bags.
- This appliance is not intended for use by persons (including children) with reduced physical, sensory or mental capabilities, or lack of experience and knowledge, unless they have been given supervision or instruction concerning use of the appliance by a person responsible for their safety. Children should be supervised to ensure that they do not play with the appliance.
- To avoid danger of suffocation, keep the plastic bag or thin film used as the packaging material away from young children.

⚠ CAUTION

- This unit must be installed by qualified personnel with a capacity certification of handling refrigerant fluids. Refer to regulation and laws in use on installation place.
- Install the unit by following local codes and regulations in force in the place of installation, and the installation instructions of the manufacturer.
- This unit is part of a set constituting an air conditioner. The unit must not be installed alone or be installed with device not authorized by the manufacturer.
- When installing pipes shorter than 5 m, sound of the outdoor unit will be transferred to the indoor unit, which will cause large operating sound or some abnormal sound.
- Always use a separate power supply line protected by a circuit breaker operating on all wires with a distance between contact of 3mm for this unit.
- To protect the persons, earth (ground) the unit correctly, and use the power cable combined with an Earth Leakage Circuit Breaker (ELCB).
- The units are not explosion proof, and therefore should not be installed in explosive atmosphere.
- This unit contains no user-serviceable parts. Always consult experienced service technician for repairing.
- When moving or relocating the air conditioner, consult experienced service technicians for disconnection and installation of the unit.
- Children should be monitored to ensure they do not play with the device.
- Do not touch the aluminum fins of heat exchanger built-in the indoor or outdoor unit to avoid personal injury when you install or maintain the unit.
- Do not place any other electrical products or household belongings under indoor unit or outdoor unit. Dripping condensation from the unit might get them wet, and may cause damage or malfunction of your property.

2. ABOUT THIS PRODUCT

2.1. Precautions for using R410A refrigerant

⚠ WARNING

- Do not introduce any substance other than the prescribed refrigerant into the refrigeration cycle. If air enters the refrigeration cycle, the pressure in the refrigeration cycle will become abnormally high and cause the piping to rupture.
- If there is a refrigerant leak, make sure that it does not exceed the concentration limit. If a refrigerant leak exceeds the concentration limit, it can lead to accidents such as oxygen starvation.
- Do not touch refrigerant that has leaked from the refrigerant pipe connections or other areas. Touching the refrigerant directly can cause frostbite.
- If a refrigerant leak occurs during operation, immediately vacate the premises and thoroughly ventilate the area. If the refrigerant comes in contact with a flame, it produces a toxic gas.
- The basic installation work procedures are the same as conventional refrigerant models. However, pay careful attention to the following points:
 - Since the working pressure is 1.6 times higher than that of conventional refrigerant (R22) models, some of the piping and installation and service tools are special. (See the table below.) Especially, when replacing a conventional refrigerant (R22) model with a new refrigerant R410A model, always replace the conventional piping and flare nuts with the R410A piping and flare nuts.

- Models that use refrigerant R410A have a different charging port thread diameter to prevent erroneous charging with conventional refrigerant (R22) and for safety. Therefore, check beforehand. [The charging port thread diameter for R410A is 1/2-20 UNF.]
- Be careful that foreign matter (oil, water, etc.) does not enter the piping than with refrigerant models. Also, when storing the piping, securely seal the openings by pinching, taping, etc.
- When charging the refrigerant, take into account the slight change in the composition of the gas and liquid phases. And always charge from the liquid phase where refrigerant composition is stable.

2.2. Special tools for R410A refrigerant

⚠ WARNING

To install a unit that uses R410A refrigerant, use dedicated tools and piping materials that have been manufactured specifically for R410A use. Because the pressure of R410A refrigerant is approximately 1.6 times higher than R22, failure to use dedicated piping material or improper installation can cause rupture or injury. Furthermore, it can cause serious accidents such as water leakage, electric shock, or fire.



Tool name	Changes
Gauge manifold	Pressure is high and cannot be measured with a conventional gauge. To prevent erroneous mixing of other refrigerants, the diameter of each port has been changed. It is recommended the gauge with seals -0.1 to 5.3 MPa (-1 to 53 bar) for high pressure. -0.1 to 3.8 MPa (-1 to 38 bar) for low pressure.
Charging hose	To increase pressure resistance, the hose material and base size were changed.
Vacuum pump	A conventional vacuum pump can be used by installing a vacuum pump adapter.
Gas leakage detector	Special gas leakage detector for HFC refrigerant R410A.

2.3. Accessories

⚠ WARNING

For installation purposes, be sure to use the parts supplied by the manufacturer or other prescribed parts. The use of non-prescribed parts can cause serious accidents such as the unit falling, water leakage, electric shock, or fire.

Following installation parts are supplied. Use them as required. Keep this manual in a safe place, and do not discard any other accessories until the installation work has been completed.

Name and shape	Q'ty	Description
Installation manual 	1	This manual
Drain pipe 	1	(Reverse cycle model only)
Drain cap 	5	—

The following items are necessary to install this air conditioner. (The items are not included with the air conditioner and must be purchased separately.)

Name			
Connection pipe assembly	Decorative tape	Saddle	Tapping screws
Connection cable	Vinyl tape	Drain hose	Sealant
Wall pipe	Wall cap	M10 bold, nut	

2.4. Operating range

Outdoor	Cooling/Dry Mode	Heating Mode
Temperature	-5 to 115°F (-20 to 46°C)	-5 to 75°F (-20 to 24°C)

- If operated at a temperature beyond the specified operating range, a protection circuit may be activated to stop the operation of the unit.

3. GENERAL SPECIFICATION

3.1. Selecting circuit breaker and wiring

⚠ CAUTION

- Be sure to install a breaker of the specified capacity.
- Regulation of cables and breaker differs from each locality, refer in accordance with local rules.

Voltage rating	1 ø 208/230 V (60 Hz)
Operating range	188-253 V

Cable	Cable size (AWG)	Cable type	Remark
Power supply cable	AWG 16 to 14	Sheathed PVC cable	2 wire + Earth (Ground)
Connection cable	AWG 20 to 16	Sheathed PVC cable	3 wire + Earth (Ground)

Select the correct cable type and size according to the country or region's regulations.
Cable Length: Limit voltage drop to less than 2%. Increase cable gauge if voltage drop is 2% or more.

⚠ CAUTION

MODEL	18	24	30	36
MINIMUM CIRCUIT AMPACITY	18.3 A	20.8 A	20.8 A	24.6 A
MAX. CKT. BKR. (MAXIMUM CIRCUIT BREAKER)	20 A	30 A	30 A	30 A

- Before starting work check that power is not being supplied to all poles of the indoor unit and outdoor unit.
- Install all electrical works in accordance to the national standard.
- Install the disconnect device with a contact gap of at least 2/16 in (3 mm) in all poles nearby the units. (Both indoor unit and outdoor unit)
- Install the circuit breaker nearby the units.

3.2. Selecting the pipe material

⚠ CAUTION

- Do not use existing pipes.
- Use pipes that have clean external and internal sides without any contamination which may cause trouble during use, such as sulfur, oxide, dust, cutting waste, oil, or water.
- It is necessary to use seamless copper pipes.
Material: Phosphor deoxidized seamless copper pipes.
It is desirable that the amount of residual oil is less than 40 mg/33ft (10m).
- Do not use copper pipes that have a collapsed, deformed, or discolored portion (especially on the interior surface). Otherwise, the expansion valve or capillary tube may become blocked with contaminants.
- Improper pipe selection will degrade performance. As an air conditioner using R410A incurs pressure higher than when using conventional refrigerant, it is necessary to choose adequate materials.

NOTES:

Thicknesses of copper pipes used with R410A are as shown in the table.
Never use copper pipes thinner than those indicated in the table even if they are available on the market.

Thicknesses of Annealed Copper Pipes (R410A)

Pipe outside diameter [in (mm)]	Thickness [in (mm)]
1/4 (6.35)	0.032 (0.80)
3/8 (9.52)	0.032 (0.80)
1/2 (12.70)	0.032 (0.80)
5/8 (15.88)	0.039 (1.00)
3/4 (19.05)	0.047 (1.20)

3.3. Connection pipe requirement

⚠ CAUTION

If the pipe lengths and height differences are not kept as shown in the table, correct operation cannot be guaranteed.

Model	Diameter		Pipe length		Maximum height (between indoor and outdoor)
	Liquid	Gas	MAX.	MIN.	
18	1/4 in (6.35 mm)	1/2 in (12.70 mm)	165 ft (50 m)	17 ft (5 m)	98 ft (30 m)
24	3/8 in (9.52 mm)	5/8 in (15.88 mm)	165 ft (50 m)	17 ft (5 m)	98 ft (30 m)
30	3/8 in (9.52 mm)	5/8 in (15.88 mm)	165 ft (50 m)	17 ft (5 m)	98 ft (30 m)
36	3/8 in (9.52 mm)	5/8 in (15.88 mm)	165 ft (50 m)	17 ft (5 m)	98 ft (30 m)

3.4. Additional charging

Refrigerant suitable for a piping length of 66 ft (20 m) is charged in the outdoor unit at the factory.

When the piping is longer than 66 ft (20 m), additional charging is necessary.
For the additional amount, see the table below.

Model	Piping length	66 ft (20 m)	98 ft (30 m)	131 ft (40 m)	165 ft (50 m)	Rate
18	Additional charge	None	7 oz (200 g)	14 oz (400g)	1 lb 5 oz (600 g)	0.22 oz/ft (20 g)
24/30/36		None	14 oz (400 g)	1 lb 12 oz (800 g)	2 lb 10 oz (1200 g)	0.43 oz/ft (40 g)

⚠ CAUTION

When adding refrigerant, add the refrigerant from the charging port at the completion of work.

4. INSTALLATION WORK

Make sure to obtain the customer's approval for selecting and installing the outdoor unit.

4.1. Selecting an installation location

⚠ WARNING

- Install at a place that can withstand the weight of the outdoor units and install positively so that the units will not topple or fall.
- Be sure to install the outdoor unit as prescribed, so that it can withstand earthquakes and typhoons or other strong winds. Improper installation can cause the unit to topple or fall, or other accidents.
- Do not install the outdoor unit near the edge of a balcony. Otherwise, children may climb onto the outdoor unit and fall off of the balcony.

⚠ CAUTION

- Do not install the outdoor unit in the following areas:
 - Area with high salt content, such as at the seaside. It will deteriorate metal parts, causing the parts to fail or the unit to leak water.
 - Area filled with mineral oil or containing a large amount of splashed oil or steam, such as a kitchen. It will deteriorate plastic parts, causing the parts to fail or the unit to leak water.
 - Area that generates substances that adversely affect the equipment, such as sulfuric gas, chlorine gas, acid, or alkali. It will cause the copper pipes and brazed joints to corrode, which can cause refrigerant leakage.
 - Area containing equipment that generates electromagnetic interference. It will cause the control system to malfunction, preventing the unit from operating normally.
 - Area that can cause combustible gas to leak, contains suspended carbon fibers or flammable dust, or volatile inflammables such as paint thinner or gasoline. If gas leaks and settles around the unit, it can cause a fire.
 - Area where small animals may live. It may cause failure, smoke or fire if small animals enter and touch internal electrical parts.
 - Area where animals may urinate on the unit or ammonia may be generated.
- Do not tilt the outdoor unit more than 3 degrees.
- Install the outdoor unit in a well-ventilated location away from rain or direct sunlight.
- If the outdoor unit must be installed in an area within easy reach of the general public, install as necessary a protective fence or the like to prevent their access.
- Install the outdoor unit in a location that would not inconvenience your neighbors, as they could be affected by the airflow coming out from the outlet, noise, or vibration. If it must be installed in proximity to your neighbors, be sure to obtain their approval.
- Do not install in an area that has heat sources, vapors, or the risk of leakage or accumulation of flammable gas.
- If the outdoor unit is installed in a cold region that is affected by snow accumulation, snow fall, or freezing, take appropriate measures to protect it from those elements. To ensure a stable operation, install inlet and outlet ducts.
- Do not install the unit where a strong wind blows or where it is very dusty.
- Install the unit where keep away more than 3 m from the antenna of TV set and Radio.
- If children under 10 years old may approach the unit, take preventive measures so that they cannot reach the unit.
- Keep the length of the piping of the indoor and outdoor units within the allowable range.
- Outdoor unit should be set to a place where both drainage and itself will not be affected when heating.
- For maintenance purposes, do not bury the piping.

4.2. Installation dimensions

⚠ CAUTION

- The installation space shown in the following examples is based on an ambient temperature under cooling operation of 95°F (35°C) (DB) at the air intake of the outdoor unit. Provide more space around the air intake than shown in the examples if the ambient temperature exceeds 95°F (35°C) (DB) or if the thermal load of all of the outdoor units exceeds the capacity.
- Consider the transportation route, installation space, maintenance space, and access, and install the unit in a location with sufficient space for the refrigerant piping.
- Installation methods not shown in the following examples are not recommended. Performance may drop significantly.

4.2.1. Single outdoor unit installation

When the upward area is open [Unit: in (mm)]

(1) Obstacles at rear only

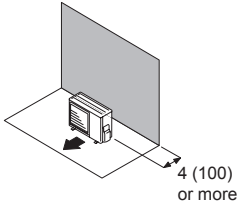

(2) Obstacles at rear and sides only

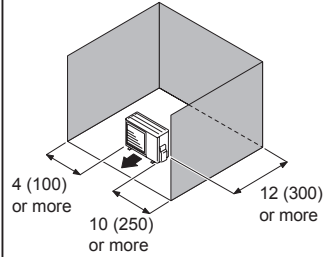

(3) Obstacles at front only

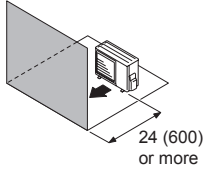

(4) Obstacles at front and rear only

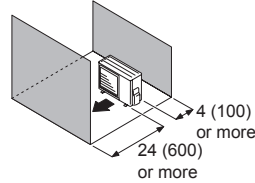

When an obstruction is present also in the upward area [Unit: in (mm)]

(1) Obstacles at rear and above only

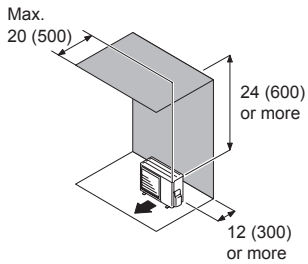

(2) Obstacles at rear, sides, and above only

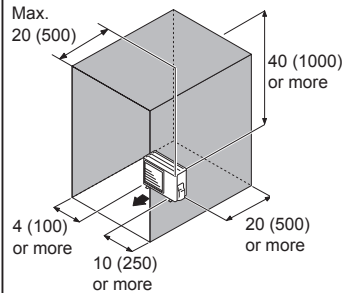

4.2.2. Multiple outdoor unit installation

- Provide at least 10 in (250 mm) of space between the outdoor units if multiple units are installed.
- When routing the piping from the side of an outdoor unit, provide space for the piping.
- No more than 3 units must be installed side by side. When 3 units or more are arranged in a line, provide the space as shown in the following example when an obstruction is present also in the upward area.

When the upward area is open [Unit: in (mm)]

(1) Obstacles at rear only

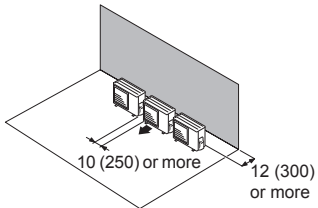

(2) Obstacles at front only

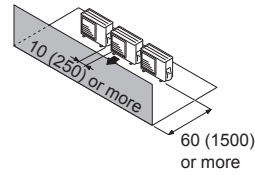

(3) Obstacles at front and rear only

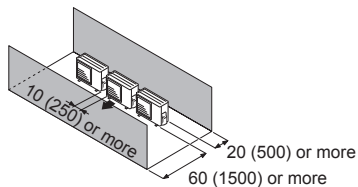

When an obstruction is present also in the upward area [Unit: in (mm)]

Obstacles at rear and above only

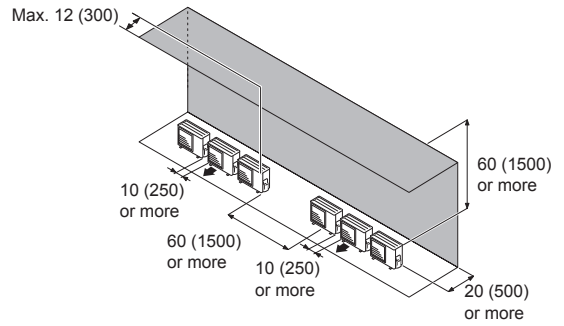

4.2.3. Outdoor units installation in multi row [Unit: in (mm)]

(1) Single parallel unit arrangement

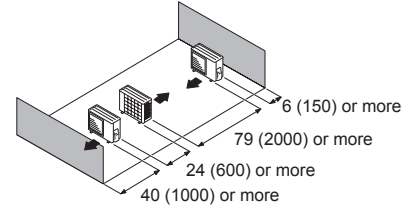

(2) Multiple parallel unit arrangement

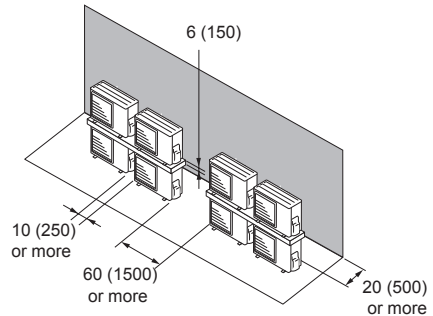
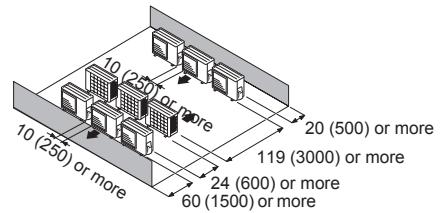

NOTES:

- If the space is larger than stated above, the condition will be the same as when there is no obstacle.
- Height above the floor level should be 50 mm or more.
- When installing the outdoor unit, be sure to open the front and left side to obtain better operation efficiency.

4.3. Transporting the unit

WARNING

Do not touch the fins.
Otherwise, personal injury could result.

CAUTION

When carrying the unit, hold the handles on the right and left sides and be careful. If the outdoor unit is carried from the bottom, hands or fingers may be pinched.

- Be sure to hold the handles on the sides of the unit. Otherwise, the suction grilles on the sides of the unit may be deformed.

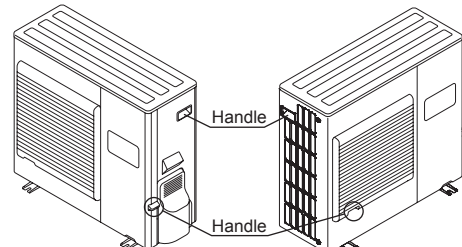

4.4. Drain installation

CAUTION

- Perform drain work in accordance with this Manual, and ensure that the drain water is properly drained. If the drain work is not carried out correctly, water may drip down from the unit, wetting the furniture.
- When the outdoor temperature is 32 °F (0 °C) or less, do not use the accessory drain pipe and drain cap. If the drain pipe and drain cap are used, the drain water in the pipe may freeze in extremely cold weather. (Reverse cycle model only)
- Please set up the outdoor unit in a high place and please do not arrange the frame of installed stand under the drain port, because the water dropped from the drain port repeats freezing and accumulating, and may block the drain port.
- In the area with heavy snowfall, if the intake and outlet of outdoor unit is blocked with snow, it is likely to cause of the breakdown. Please construct a canopy and a pedestal or place the unit on a high stand (local configured).

Bottom side AIR Drain cap mounting place

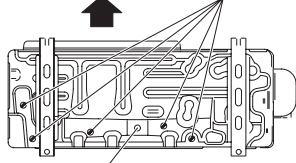

Drain pipe mounting place

- Since the drain water flows out of the outdoor unit during heating operation, install the drain pipe and connect it to a commercial 5/8 in (16 mm) hose. (Reverse cycle model only)
- When installing the drain pipe, plug all the holes other than the drain pipe mounting hole in the bottom of the outdoor unit with Drain cap (accessories) so there is no water leakage. (Reverse cycle model only)

Drain pipe mounting hole

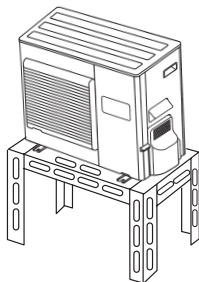
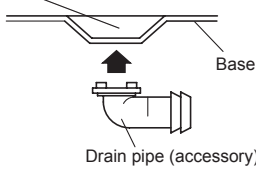

4.5. Secure the unit

WARNING

- Install the unit where it will not be tilted by more than 3°. However, do not install the unit with it tilted towards the side containing the compressor.
- When installing the outdoor unit where it may be exposed to strong wind, fasten it securely.

[Unit: in (mm)]

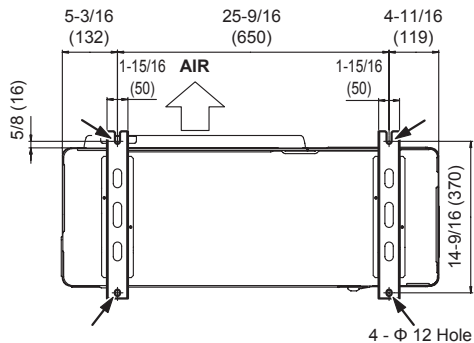

- Install 4 anchor bolts at the locations indicated with arrows in the above figure.
- To reduce vibration, do not install the unit directly on the ground. Install it on a secure base (such as concrete blocks).
- The foundation shall support the legs of the unit and have a width of 2 in (50 mm) or more.
- Depending on the installation conditions, the outdoor unit may spread its vibration during operation, which may cause noise and vibration. Therefore, attach damping materials (such as damping pads) to the outdoor unit during installation.
- Install the foundation, making sure that there is enough space for installing the connection pipes.

- Secure the unit to a solid block using foundation bolts. (Use 4 sets of commercially available M10 bolts, nuts, and washers.)
- The bolts should protrude 13/16 in (20 mm). (Refer to the figure below.)
- If overturning prevention is required, purchase the necessary commercially available items.

Fix securely with bolts on a solid block.

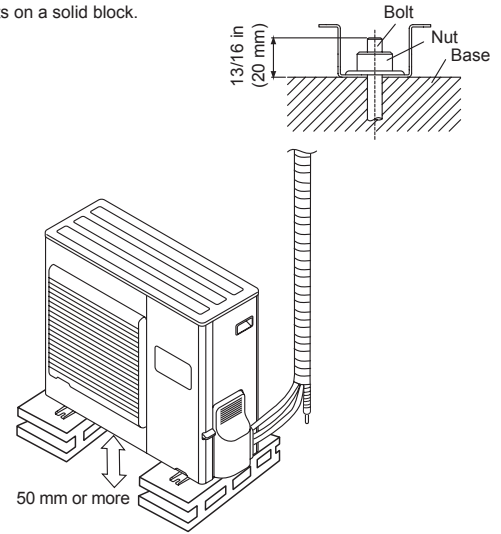

5. PIPE INSTALLATION

5.1. Brazing

CAUTION

- If air or another type of refrigerant enters the refrigeration cycle, the internal pressure in the refrigeration cycle will become abnormally high and prevent the unit from exerting its full performance.
- Apply nitrogen gas while brazing the pipes. If a pipe is brazed without applying nitrogen gas, an oxidation film will be created. This can degrade performance or damage the parts in the unit (such as the compressor or valves).

Nitrogen gas pressure: 0.02 MPa
(= pressure felt sufficiently on the back of the hand)

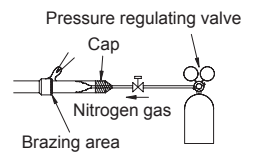

- For brazing material, use phosphor copper that does not require flux. Do not use flux to braze pipes. If the flux is the chlorine type, it will cause the pipes to corrode. Furthermore, if the flux contains fluoride, it will adversely affect the refrigerant pipe system such as by degrading the refrigerant. If fluoride is contained, quality of refrigerant deteriorates and affects the refrigerant piping system.

5.2. Flare connection (pipe connection)

5.2.1. Flaring

Use special pipe cutter and flare tool exclusive for R410A.

- Cut the connection pipe to the necessary length with a pipe cutter.
- Hold the pipe downward so that the cuttings will not enter the pipe and remove any burrs.
- Insert the flare nut (always use the flare nut attached to the indoor and outdoor units respectively) onto the pipe and perform the flare processing with a flare tool. Leakage of refrigerant may result if other flare nuts are used.
- Protect the pipes by pinching them or with tape to prevent dust, dirt, or water from entering the pipes.

Check if [L] is flared uniformly and is not cracked or scratched.

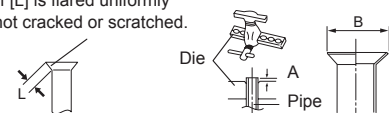

Pipe outside diameter [in (mm)]	Dimension A [in (mm)]	Dimension B [in (mm)]
	Flare tool for R410A, clutch type	
1/4 (6.35)	0 to 0.020 (0 to 0.5)	3/8 (9.1)
3/8 (9.52)		1/2 (13.2)
1/2 (12.70)		5/8 (16.6)
5/8 (15.88)		3/4 (19.7)
3/4 (19.05)		15/16 (24.0)

When using conventional flare tools to flare R410A pipes, the dimension A should be approximately 0.020 in (0.5 mm) more than indicated in the table (for flaring with R410A flare tools) to achieve the specified flaring. Use a thickness gauge to measure the dimension A.

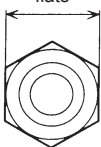
Width across flats	Pipe outside diameter [in (mm)]	Width across flats of Flare nut [in (mm)]
	1/4 (6.35)	11/16 (17)
	3/8 (9.52)	7/8 (22)
	1/2 (12.70)	1 (26)
	5/8 (15.88)	1-1/8 (29)
	3/4 (19.05)	1-7/16 (36)

5.2.2. Bending pipes

CAUTION

- To prevent breaking of the pipe, avoid sharp bends. Bend the pipe with a radius of curvature of 3-15/16 in (100 mm) to 5-14/16 in (150 mm).
- If the pipe is bent repeatedly at the same place, it will break.
- If pipes are shaped by hand, be careful not to collapse them.
- Do not bend the pipes at an angle of more than 90°.
- When pipes are repeatedly bent or stretched, the material will harden, making it difficult to bend or stretch them any more.
- Do not bend or stretch the pipes more than three times.

5.2.3. Pipe connection

CAUTION

- Be sure to install the pipe against the port on the indoor unit and the outdoor unit correctly. If the centering is improper, the flare nut cannot be tightened smoothly. If the flare nut is forced to turn, the threads will be damaged.
- Do not remove the flare nut from the outdoor unit pipe until immediately before connecting the connection pipe.
- After installing the piping, make sure that the connection pipes do not touch the compressor or outer panel. If the pipes touch the compressor or outer panel, they will vibrate and produce noise.

- Service cover removal
 - Remove the two mounting screws.
 - Remove the service cover by pushing downwards.

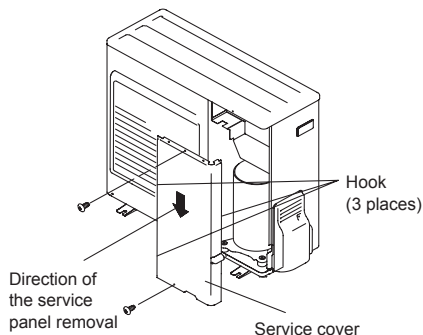

- Valve cover removal.
 - Remove the one mounting screw.
 - Remove the valve cover by sliding upward.

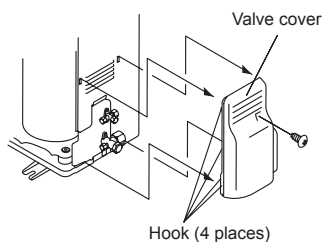

- Install the outdoor unit wall cap (supplied with the optional installation set or procured at the site) to the wall pipe.
- Connect the outdoor unit and indoor unit piping.
- After matching the center of the flare surface and tightening the nut hand tight, tighten the nut to the specified tightening torque with a torque wrench.

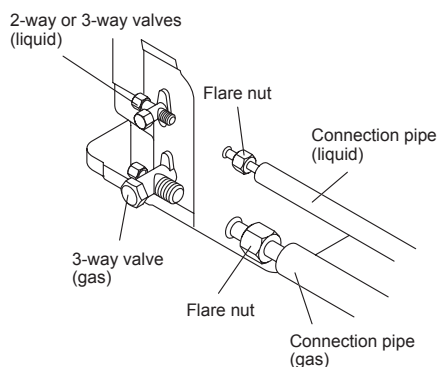

CAUTION

Hold the torque wrench at its grip, keeping it in a right angle with the pipe, in order to tighten the flare nut correctly.

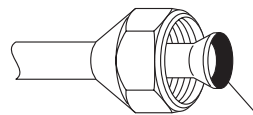
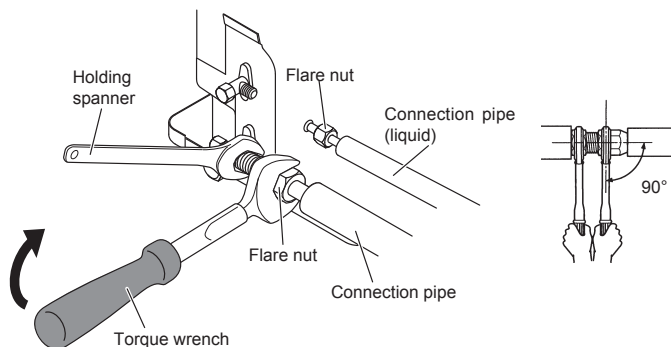

To prevent gas leakage, coat the flare surface with refrigerator oil.

Flare nut [in (mm)]	Tightening torque [ft·lb (N·m)]
1/4 (6.35) dia.	12 to 13 (16 to 18)
3/8 (9.52) dia.	24 to 31 (32 to 42)
1/2 (12.70) dia.	36 to 45 (49 to 61)
5/8 (15.88) dia.	46 to 55 (63 to 75)
3/4 (19.05) dia.	66 to 81 (90 to 110)

5.3. Sealing test

WARNING

- Before operating the compressor, install the pipes and securely connect them. Otherwise, if the pipes are not installed and if the valves are open when the compressor operates, air could enter the refrigeration cycle. If this happens, the pressure in the refrigeration cycle will become abnormally high and cause damage or injury.
- After the installation, make sure there is no refrigerant leakage. If the refrigerant leaks into the room and becomes exposed to a source of fire such as a fan heater, stove, or burner, it produces a toxic gas.
- Do not subject the pipes to strong shocks during the sealing test. It can rupture the pipes and cause serious injury.

CAUTION

Do not block the walls and the ceiling until the sealing test and the charging of the refrigerant gas have been completed.

- After connecting the pipes, perform a sealing test.
- Make sure that the 3-way valves are closed before performing a sealing test.
- Pressurize nitrogen gas to 4.15 MPa to perform the sealing test.
- Add nitrogen gas to both the liquid pipes and the gas pipes.
- Check all flare connections and welds. Then, check that the pressure has not decreased.
- Compare the pressures after pressurizing and letting it stand for 24 hours, and check that the pressure has not decreased.
 - * When the outdoor air temperature changes 41°F (5°C), the test pressure changes 0.05 MPa. If the pressure has dropped, the pipe joints may be leaking.
- If a leak is found, immediately repair it and perform the sealing test again.
- After completing the sealing test, release the nitrogen gas from both valves.
- Release the nitrogen gas slowly.

5.4. Vacuum process

CAUTION

- Perform a refrigerant leakage test (air tightness test) to check for leaks using nitrogen gas while all valves in the outdoor unit are closed. (Use the test pressure indicated on the nameplate.)
- Be sure to evacuate the refrigerant system using a vacuum pump.
- The refrigerant pressure may sometimes not rise when a closed valve is opened after the system is evacuated using a vacuum pump. This is caused by the closure of the refrigerant system of the outdoor unit by the electronic expansion valve. This will not affect the operation of the unit.
- If the system is not evacuated sufficiently, its performance will drop.
- Use a clean gauge manifold and charging hose that were designed specifically for use with R410A. Using the same vacuum equipment for different refrigerants may damage the vacuum pump or the unit.
- Do not purge the air with refrigerants, but use a vacuum pump to evacuate the system.

- Remove the cap, and connect the gauge manifold and the vacuum pump to the charging valve by the service hoses.
- Vacuum the indoor unit and the connecting pipes until the pressure gauge indicates -0.1 MPa (-76 cmHg).
- When -0.1 MPa (-76 cmHg) is reached, operate the vacuum pump for at least 60 minutes.
- Disconnect the service hoses and fit the cap to the charging valve to the specified torque.
- Remove the blank caps, and fully open the spindles of the 3-way (Liquid) and 3-way (Gas) valves with a hexagon wrench.
- Tighten the blank caps of the 3-way (Liquid) valve and 3-way (Gas) valve to the specified torque.

		Tightening torque
Blank cap	1/4 in (6.35 mm)	15 to 18 ft-lb (20 to 25 N-m)
	3/8 in (9.52 mm)	15 to 18 ft-lb (20 to 25 N-m)
	1/2 in (12.70 mm)	21 to 24 ft-lb (28 to 32 N-m)
	5/8 in (15.88 mm)	22 to 26 ft-lb (30 to 35 N-m)
Charging port cap (R410A)		9 to 12 ft-lb (12.5 to 16 N-m)

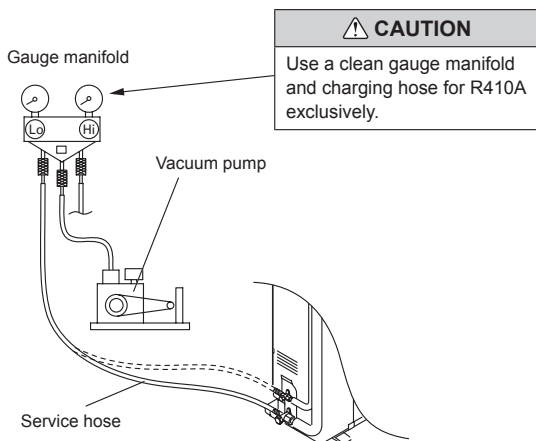
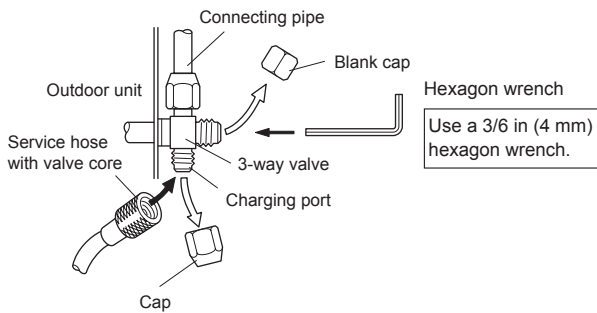

5.5. Additional charge

CAUTION

- When moving and installing the air conditioner, do not mix gas other than the specified refrigerant R410A inside the refrigerant cycle.
- When charging the refrigerant R410A, always use an electronic balance for refrigerant charging (to measure the refrigerant by weight).
- When charging the refrigerant, take into account the slight change in the composition of the gas and liquid phases, and always charge from the liquid phase side whose composition is stable.
- Add refrigerant from the charging valve after the completion of the work.
- If the units are further apart than the maximum pipe length, correct operation cannot be guaranteed.

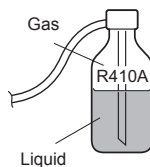

5.6. Gas leakage inspection

CAUTION

- After connecting the piping, check the all joints for gas leakage with gas leak detector.
- When inspecting gas leakage, always use the vacuum pump for pressure. Do not use nitrogen gas.

6. ELECTRICAL WIRING

6.1. Notes for electrical wiring

WARNING

- Wiring connections must be performed by a qualified person in accordance with the specifications. The voltage rating for this product is 208-230 V at 60 Hz. It should be operated within the range of 188 to 253 V.
- Before connecting the wires, make sure the power supply is OFF.
- Use a dedicated power supply circuit. Insufficient power capacity in the electrical circuit or improper wiring may cause electric shock or fire.
- Install a breaker at the power supply for each outdoor unit. Improper breaker selection can cause electric shock or fire.
- Install a leakage circuit breaker in accordance with the related laws and regulations. An improperly installed electrical box cover can cause serious accidents such as electric shock or fire through exposure to dust or water.
- A circuit breaker is installed in the permanent wiring. Always use a circuit that can trip all the poles of the wiring and has an isolation distance of at least 1/8 in (3 mm) between the contacts of each pole.
- Use designated cables and power cables. Improper use may cause electric shock or fire by poor connection, insufficient insulation, or over current.
- Do not modify power cable, use extension cable or branch wiring. Improper use may cause electric shock or fire by poor connection, insufficient insulation or over current.
- Connect the connector cable securely to the terminals. Check no mechanical force bears on the cables connected to the terminals. Faulty installation can cause a fire.
- Use ring type terminals and tighten the terminal screws to the specified torques, otherwise, abnormal overheating may be produced and possibly cause serious damage inside the unit.
- Make sure to secure the insulation portion of the connector cable with the cable clamp. Damaged insulation can cause a short circuit.
- Fix cables so that cables do not make contact with the pipes (especially on high pressure side). Do not make power supply cable and connection cable come in contact with valves (Gas).
- Never install a power factor improvement condenser. Instead of improving the power factor, the condenser may overheat.
- Be sure to perform the earthing (grounding) work.
 - Do not connect earthing (grounding) wires to a gas pipe, water pipe, lightning rod or earthing (grounding) wire for a telephone.
 - Connection to a gas pipe may cause a fire or explosion if gas leaks.
 - Connection to a water pipe is not an effective earthing (grounding) method if PVC pipe is used.
 - Connection to the earthing (grounding) wire of a telephone or to a lightning rod may cause a dangerously abnormal rise in the electrical potential if lightning strikes. Improper earthing (grounding) work can cause electric shocks.
- Securely install the electrical box cover on the unit. An improperly installed service panel can cause serious accidents such as electric shock or fire through exposure to dust or water.

CAUTION

- The primary power supply capacity is for the air conditioner itself, and does not include the concurrent use of other devices.
- Do not start operation until the refrigerant is charged completely. The compressor will fail if it is operated before the refrigerant piping charging is complete.
- Connection cable between indoor unit and outdoor unit is 208-230 V.
- Be sure not to remove thermistor sensor etc. from power wiring and connection wiring. Compressor may fail if operated while removed.
- Start wiring work after closing branch switch and over current breaker.
- Use an earth leakage breaker that is capable of handling high frequencies. Because the outdoor unit is inverter controlled, a high-frequency earth leakage breaker is necessary to prevent a malfunction of the breaker itself.
- When using an earth leakage breaker that has been designed solely for earth (ground) fault protection, be sure to install a fuse-equipped switch or circuit breaker.
- Do not connect the AC power supply to the connection line terminal board. Improper wiring can damage the entire system.
- Do not use crossover power supply wiring for the outdoor unit.
- If the temperature surrounding the breaker is too high, the amperage at which the breaker cuts out may decrease.
- When connecting the power supply cable, make sure that the phase of the power supply matches with the phase of the terminal board. If the phases do not match, the compressor will rotate in reverse and will not be able to compress.

- Service cover removal
 - Remove the two mounting screws.
 - Remove the service cover by pushing downwards.

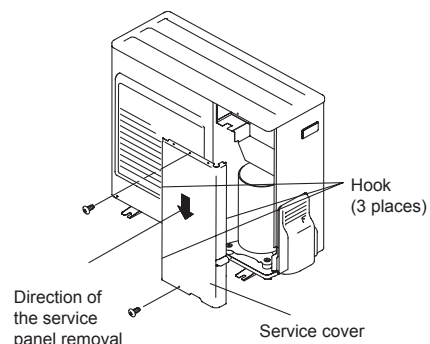

- (2) Fasten the power supply cable and the connection cable to the conduit holder using the lock nut.
(open the knock out holes if necessary)

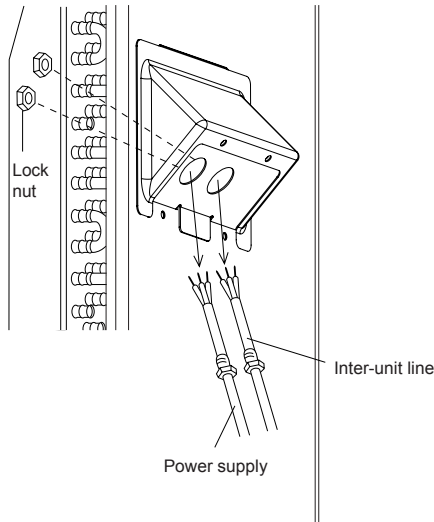

Keep the earth wire longer than the other wires.

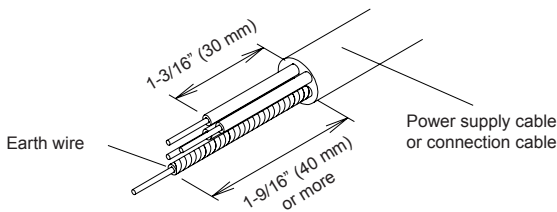

- (3) Connect the power supply cable and the connection cable to terminal.
(4) Fasten the power supply cable and connection cable with cable clamp.

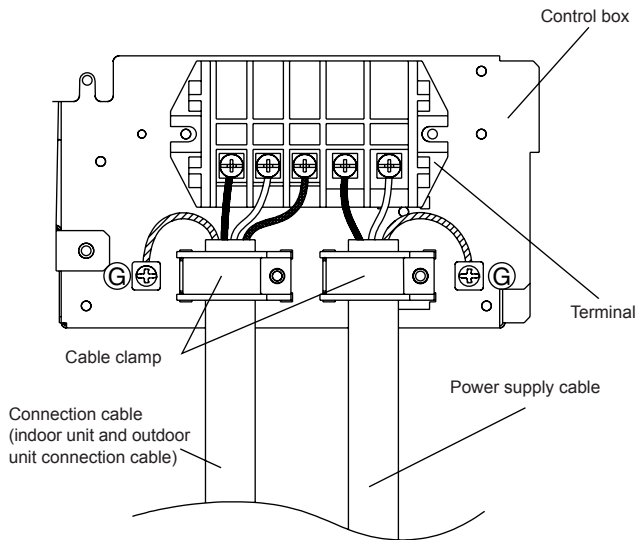

WARNING

- Disconnect switch for over current protection given in the table below is to be installed between the indoor unit and the outdoor unit.
- Use ring terminals and tighten the terminal screws to the specified torques, otherwise, abnormal overheating may be produced and possibly cause heavy damage inside the unit.
- Match the terminal block numbers and connection cable colors with those of the outdoor unit. Erroneous wiring may cause burning of the electric parts.
- Connect the connection cables firmly to the terminal block. Imperfect installation may cause a fire.
- Always fasten the outside covering of the connection cable with the cable clamp. (If the insulator is chafed, electric leakage may occur.)
- Securely earth the power cable plug.
- Do not use the earth screw for an external connector. Only use for interconnection between two units.

Disconnect switch
20A

CAUTION

- Be sure to comply with local codes while running the wire from the indoor unit to the outdoor unit (size of wire and wiring method, etc.).
- Every wire must be connected firmly.
- No wire should be allowed to touch refrigerant tubing, the compressor or any moving part.
- Loose wiring may cause the terminal to overheat or result in unit malfunction. A fire hazard may also exist. Therefore, be sure all wiring is tightly connected.
- Connect wires to the matching numbers of terminals.

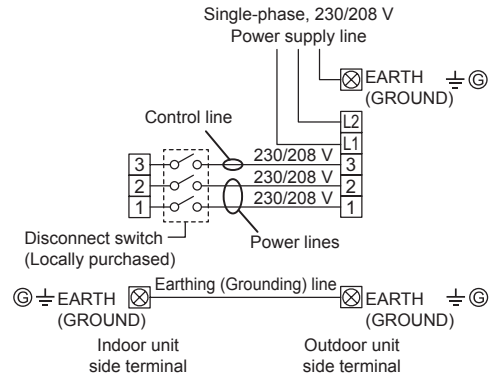

NOTES:

Factory installed protective inline fuses for indoor units' conductors are installed on the Power Supply PCB.

How to connect wiring to the terminal

Caution when wiring cable

- When stripping off the coating of a lead wire, always use a special tool such as a wire stripper. If there is no special tool available, carefully strip the coating with a knife etc.
- (1) Use ring terminals with insulating sleeves as shown in the figure below to connect to the terminal block.
 - (2) Securely clamp the ring terminals to the wires using an appropriate tool so that the wires do not come loose.

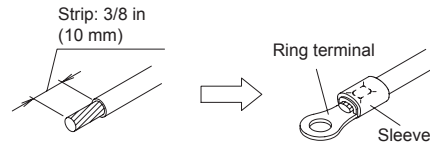

- (3) Use the specified wires, connect them securely, and fasten them so that there is no stress placed on the terminals.
- (4) Use an appropriate screwdriver to tighten the terminal screws. Do not use a screwdriver that is too small, otherwise, the screw heads may be damaged and prevent the screws from being properly tightened.
- (5) Do not tighten the terminal screws too much, otherwise, the screws may break.

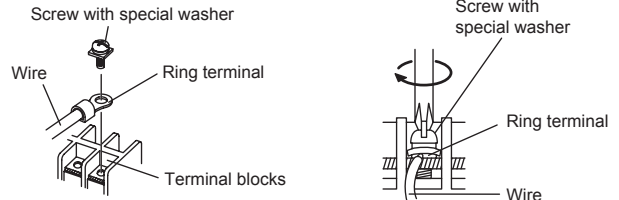

- (6) See the table below for the terminal screw tightening torques.

Tightening torque [lb-in (N·m)]	
M4 screw	11 to 16 (1.2 to 1.8)
M5 screw	17 to 25 (2.0 to 3.0)

7. TEST RUN

Make a **TEST RUN** in accordance with installation manual for the indoor unit.

CHECK ITEMS

INDOOR UNIT

For check items refer to the installation manual for the indoor unit.

OUTDOOR UNIT

- (1) Is there any abnormal noise and vibration during operation?
- (2) Will noise, wind, or drain water from the unit disturb the neighbors?
- (3) Is there any gas leakage?

CAUTION

Always turn on the power 12 hours prior to the start of the operation in order to ensure compressor protection.

8. PUMP DOWN

PUMP DOWN OPERATION (FORCED COOLING OPERATION)

To avoid discharging refrigerant into the atmosphere at the time of relocation or disposal, recover refrigerant by doing the forced cooling operation according to the following procedure.

- (1) Conduct preliminary operation for 5 to 10 minutes using the test run operation.
For test run operation refer to the installation manual for the indoor unit.
- (2) Close the valve stem of 2-way valve completely.
- (3) Continue the test run operation for 2 to 3 minutes, then close all the valve stems on the 3-way valves.
- (4) Stop the operation.
 - Press the START/STOP button of the remote controller to stop the operation.

CAUTION

- Please check the refrigerant circuit for any leaks before starting the pump down operation.
- Do not proceed with the pump down operation if there is no refrigerant left in the circuit due to bent or broken piping.
- During the pump down operation, be sure to turn off the compressor before removing the refrigerant piping.