

4SHP16LE

PRODUCT SPECIFICATIONS

16 SEER SPLIT HEAT PUMP SYSTEM
UP TO 16 SEER & 9.5 HSPF

FORM NO. 4SHP16LE-100 (2/2019)



COMPRESSOR

- High-efficiency scroll compressor
- R410A refrigerant
- Grommet mounted compressor for quiet operation
- Heavy-duty compressor sound blanket for quiet operation
- Internally protected against high temperature motor overload conditions

CABINET

- Full metal louvered construction to protect the coil
- Individual metal louvered panels remove easily for coil cleaning and service
- Corner-mounted controls for easy service
- Baked polyester paint finished over galvanized steel for maximum durability
- Removable PVC coated wire fan discharge grill
- 45-degree offset gauge ports for easy service
- Removable service panel for internal access
- External gauge ports for easy service

COILS

- Omniguard™ coil corrosion protection tube-and-fin coil design
- Enhanced tube-and-fin coil design featuring MHT™ Technology
- Lanced fins for maximum heat transfer
- Factory tested for leak-proof construction
- Raised coil prevents debris from impeding airflow

COMPONENTS

- 45-degree offset gauge ports for easy service
- Factory installed crankcase heater
- Factory installed high and low pressure switches
- Thread-on pressure switches for simple, quick service
- Filter drier shipped loose for installation flexibility
- Fan orifice for smoother airflow and sound level reduction
- Charged for 15 feet of line set
- Discharge muffler for quiet operation
- Quiet Shift™ capable to reduce noise during defrost
- Sealed Contactor with lugs

WARRANTY

10 year limited warranty on compressor
10 year limited warranty on all parts,
extended warranty available

**Warranty provides for a total of 10 years of limited warranty coverage (Standard 5-year limited parts warranty plus an additional 5-year limited extended parts warranty). Warranty must be registered online within 60 days of installation to qualify for 10-year coverage. Unregistered equipment defaults to 5-year coverage.*

NOTE:

For the latest AHRI system matches, please visit www.alliedratings.com or www.AHRInet.org



MODEL NUMBER GUIDE

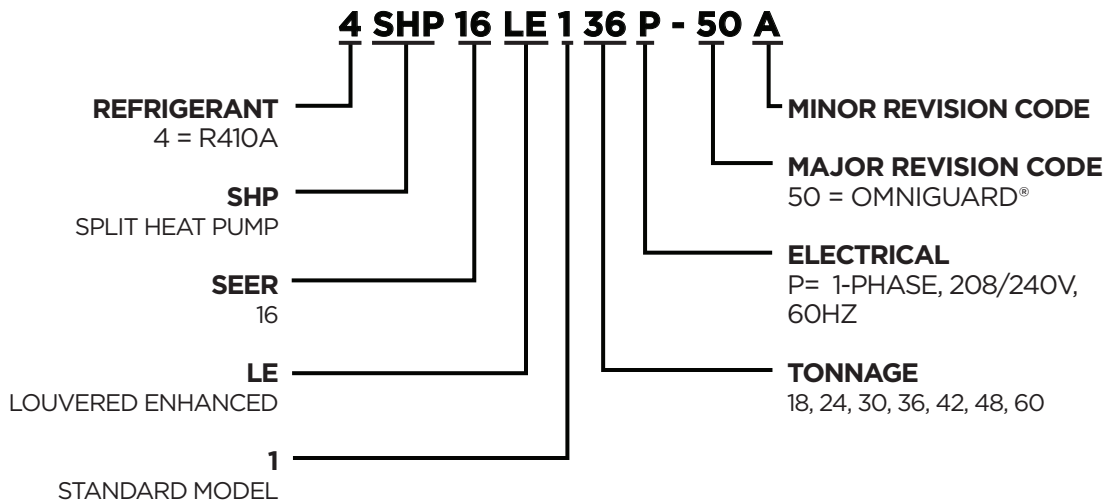

ELECTRICAL AND PHYSICAL DATA

Model	Voltage/ Hz/ Phase	Voltage Range	Min. Circuit Amp.	Max. Over Current Device (amps)	Compressor		Outdoor Fan Motor			Shipping Weight (lbs.)
					Rated Load (amps)	Locked Rotor (amps)	Full Load (amps)	Rated HP	Nom. RPM	
4SHP16LE118P-50	208-230/60/1	197-253	10.6	20	7.7	48	1.0	1/6	825	200
4SHP16LE124P-50	208-230/60/1	197-253	13.6	20	10.1	52	1.0	1/6	825	210
4SHP16LE130P-50	208-230/60/1	197-253	16.4	25	12.3	63	1.0	1/6	825	209
4SHP16LE136P-50	208-230/60/1	197-253	20.9	35	14.7	75	2.6	1/3	820	247
4SHP16LE142P-50	208-230/60/1	197-253	25	40	17.9	112.3	2.6	1/3	820	301
4SHP16LE148P-50	208-230/60/1	197-253	25.8	40	18.5	124	2.6	1/3	820	305
4SHP16LE160P-50	208-230/60/1	197-253	30.4	50	22.2	127.9	2.6	1/3	820	309

Note:
Weights listed are unit weights with packaging
+ Factory charged for 15 feet of line set. Adjust per installation instructions.

UNIT DIMENSIONS AND SOUND

Model	Dimensions (inch)			Sound Rating (dBA)
	A - Width	B - Depth	C - Height	
4SHP16LE118P-50	28.25	28.25	43.25	75
4SHP16LE124P-50	28.25	28.25	33.25	76
4SHP16LE130P-50	28.25	28.25	33.25	76
4SHP16LE136P-50	32.25	32.25	33.25	76
4SHP16LE142P-50	32.25	32.25	43.25	74
4SHP16LE148P-50	32.25	32.25	43.25	74
4SHP16LE160P-50	32.25	32.25	43.25	76

Note:
Dimensions listed are unit sizes w/o packaging

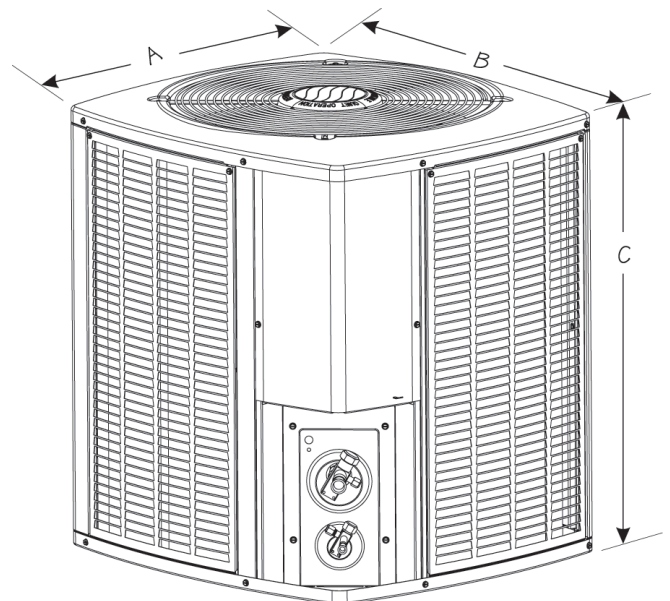

REFRIGERATION DATA

Model	Refrig. Charge (oz.) *	TXV	Refrigerant Line Size		Outdoor Unit Connection		Indoor Unit Connection	
			Suction	Liquid	Suction	Liquid	Suction	Liquid
4SHP16LE118P-50	114	3-ton	3/4	3/8	3/4	3/8	3/4	3/8
4SHP16LE124P-50	126	3-ton	3/4	3/8	3/4	3/8	3/4	3/8
4SHP16LE130P-50	132	3-ton	3/4	3/8	3/4	3/8	3/4	3/8
4SHP16LE136P-50	135	3-ton	7/8	3/8	7/8	3/8	7/8	3/8
4SHP16LE142P-50	180	4-ton	7/8	3/8	7/8	3/8	7/8	3/8
4SHP16LE148P-50	188	4-ton	7/8	3/8	7/8	3/8	7/8	3/8
4SHP16LE160P-50	182	5-ton	1-1/8	3/8	1-1/8	3/8	1-1/8	3/8

* Factory charged for 15 feet of line set; adjust per installation instructions.

** Reducer fitting supplied with OD unit

COOLING PERFORMANCE WITH AIR HANDLERS AND FURNACES

Outdoor Model	Indoor Model	Cooling				Heating				High CFM	Med CFM	Low CFM	
		SEER	EER	AHRI Rated Capacity ¹	Sensible Capacity	HSPF	47°		17°				
							Btuh	COP	Btuh				COP
4SHP16LE118P-50	BCE7E18M	16	13	18,000	15,300	9.5	17,200	3.9	10,800	2.59	675		
4SHP16LE124P-50	BCE7E24M	16	13	24,000	18,400	9.5	22,000	3.79	14,000	2.58	800		
4SHP16LE130P-50	BCE7E30M	16	13	29,800	23,000	9.5	27,400	3.81	17,600	2.64	1025		
4SHP16LE136P-50	BCE7E36M	16	13	35,400	27,200	9.5	34,000	3.79	22,400	2.75	1200		
4SHP16LE142P-50	BCE7E48M	16	13	41,000	30,500	9.5	38,000	3.75	24,500	2.66	1450		
4SHP16LE148P-50	BCE7E48M	16	13	46,000	34,500	9.5	43,000	3.68	28,500	2.73	1470		
4SHP16LE160P-50	BCE7E60M	15	12.5	56,000	39,000	9.5	53,000	3.6	35,000	2.66	1600		

1. Certified in accordance with Unitary Air Conditioner Certification Program, which is based on AHRI Standard 210/240

2. Required to achieve AHRI rating. If NA (not applicable) is in the piston column then TXV is required.

3. Blower time delay relay is standard on all Allied Air Enterprises furnace and AH products.

ACCESSORIES

Accessory Name	Catalog Number	Where Used						
		18	24	30	36	42	48	60
Mild Weather Kit	33M07	x	x	x	x	x	x	x
Monitor Kit - Service Light	76F53	x	x	x	x	x	x	x
Compressor Crankcase Heater	94M04	x	x	x	x			
Compressor Crankcase Heater	93M05					x	x	x
Compressor Sound Cover	69J0301	x	x	x	x	x	x	x
Compressor Hard Start Kit - LG	88M91	x	x	x	x	x		x
Compressor Hard Start Kit - ECT	10J42					x	x	
Compressor Low Ambient Cut-Off	45F08	x	x	x	x	x	x	x
Indoor Blower Off Delay Relay Kit	58M81	x	x	x	x	x	x	x
Low Ambient Cooling Kit	54M89	x	x	x	x	x	x	x

NOTE:

For the latest AHRI system matches, please visit www.alliedratings.com or www.AHRInet.org



1-800-448-5872

All specifications and illustrations subject to change without notice and without incurring obligations.