

PRODUCT INFORMATION PACKET

FASCO[®]

Model No:
Catalog No: A143
70219414.BLOWER...1 SPD.
Draft Inducer



Regal and Fasco are trademarks of Regal Beloit Corporation or one of its affiliated companies.
©2019 Regal Beloit Corporation, All Rights Reserved. MC017097E

REGAL[®]



Nameplate Specifications

Voltage	115 V	Motor Type	Shaded Pole
Overload Protector	Thermally	Speed	3000 RPM
Current	0.95 A	Number of Speeds	1
Frequency	60 Hz	Phase	1
Ambient Temperature	40 °C	UL	Yes
Insulation Class	B	CSA	Yes

Technical Specifications

Blower Outlet Shape	Rectangle	Motor Enclosure	Open
Blower Outlet Flange	No	Bearing Type	Ball
Outline Drawing	OUTLINE	Connection Diagram	CONNECTION

This is an uncontrolled document once printed or downloaded and is subject to change without notice. Date Created: 09/25/2019

- NOTES:
 1. NO STA-LOC REQUIRED ON IMPELLER.
 2. PACK 1 PER CONTAINER, 16 CONTAINERS PER LAYER, 5 LAYERS PER PALLET.
 80 MAX PER PALLET, PACKING ASSY: 87854000, PER 88834200 AND 88834408.
 3. INSPECTION TEST FIXTURING IS REQUIRED.
 4. CARTON LABELS MUST ALL FACE ONE DIRECTION TOWARD THE OPEN END OF THE PALLET, SEE 88834408.
 5. NO PACKAGING TAPE OVER CARTON LABELS.

THERMALLY PROTECTED
 CLASS "B" INSULATION
 416 SS SHAFT

APPLICATION:	80+ FURNACE	B	LA	FR	A	S	C	E	B	A
CUSTOMER:	FASCO DIST.	12	21	47	V	02	BB	5	0	0
CUSTOMER PN:	A143	FINISH: BLOWER - NATURAL, MOTOR - FLAT BLACK								

LEAD MATERIAL
 18 GA. 125°C 4/64 INSUL.
 X-LINKED POLY.
 (1) BLACK, (1) WHITE
 7.00/5.00 (177.8/127.0)
 W/ PIN TERMINALS
 AMP 350538-1

GROUND LEAD
 18 GA. 125°C 2/64 INSUL.
 X-LINKED POLY. GRN/YEL
 18.00/16.00 (457.2/406.4)
 W/ RING TERMINAL
 AMP 40955

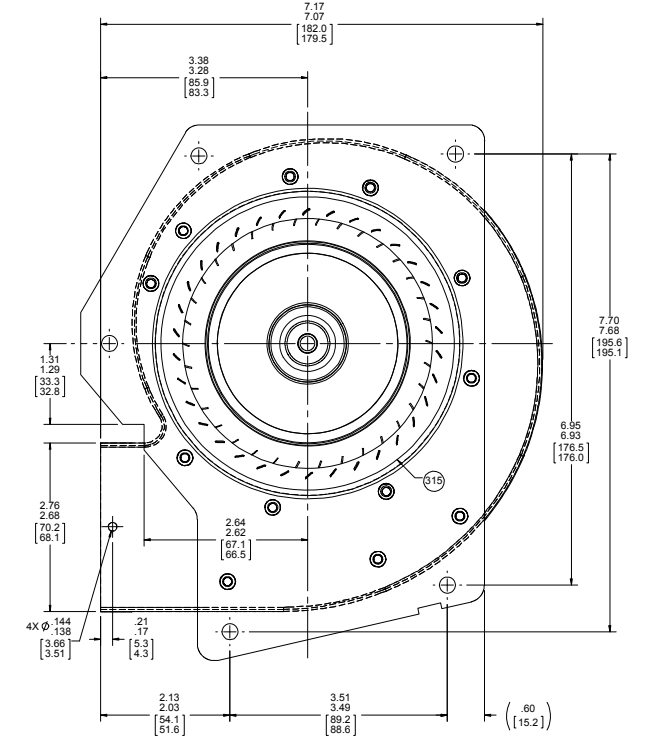
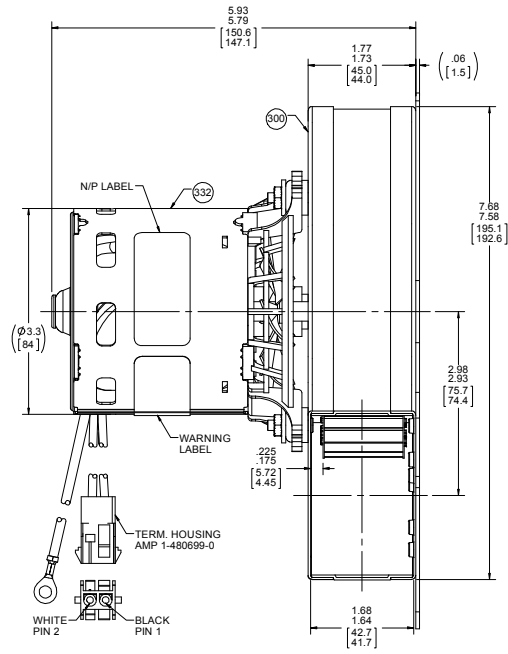
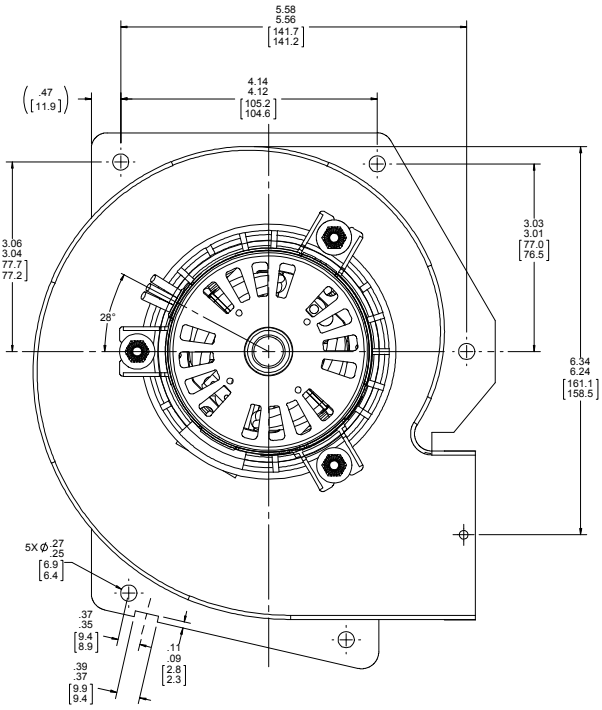
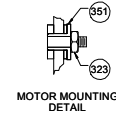

TYPICAL PERFORMANCE TEST DATA WITH 1 5/16 INLET RESTRICTOR AT 115 VOLTS 60 Hz			
	RPM	WATTS	AMPS
	3166	68	.89
BLOWER WEIGHT	4 1/2 LBS.		
ENDPLAY	XX/XX		

DRAWING REVISION	REVISION BY	REV DATES	TOLERANCES EXCEPT AS NOTED	DRAWN BY	MLS	Regal Beloit America, Inc.
AC	SEM	8/13/2019	DEC. INCH .015 .010 .005	DATE	8/18/2018	
ECO-0171983	APPROVED BY	DATE	XXX .010 .005	APPROVED BY	BAA	OUTLINE BLOWER ASSY
ECO DESCRIPTION	SED	8/13/2019	XXX .010 .005	DATE	8/18/2018	
REMOVE VIBRATION NOTE			XXX .010 .005	REFERENCE	MATERIAL	PROCESS/FINISH
REMOVE BURRS & BREAK SHARP CORNER FILLETS: R.02 (R)			XXX .010 .005	THIS ANGLE PROJECTION	SIZE	DRAWING NUMBER
MACHINED SURFACES			XXX .010 .005	REFERENCE	70219414	SHEET 1 OF 1