

## SEALED COMBUSTION DOWNFLOW GAS FURNACE

MODELS : G18D SERIES, SIZES: 60, 70, 77, 90

FOR INSTALLATION IN: MANUFACTURED (MOBILE)  
HOMES, RECREATIONAL VEHICLES, PARK MODELS,  
MODULAR HOMES AND BUILDINGS.

CAUTION: READ ALL SAFETY GUIDES  
BEFORE INSTALLING THIS GUIDE

CONTENTS	PAGE
General Information .....	1
Specifications .....	2
Safety Conditions .....	3
Installation Standards .....	3
High Altitude Installation .....	3
Installation Clearances .....	3
Return Air .....	4-5
Alcove & Closet Installation .....	5
Air Distribution Systems .....	6
Duct Connector/Base .....	6
Install Furnace .....	7
Roof Jack Selection .....	7
Cut Opening & Install Roof Jack .....	8
Installing In Snow Regions .....	8
Roof Jack On High-Pitch roof .....	8
Connect Power Supply Wires .....	9
Wall Thermostat .....	9
Connect Thermostat Wires .....	9
Gas Piping .....	9-10
High Altitude Deration Chart .....	11
Final Procedure .....	12
Furnace & Air Conditioner Installation .....	12
Blower Performance Chart .....	13
Wiring Diagrams .....	14-16



**WARNING**

### RISK OF FIRE OR ELECTRICAL SHOCK

Only qualified service personnel shall be used to install and provide maintenance of this furnace.

### GENERAL INFORMATION

These down flow sealed combustion furnaces install in Manufactured Homes, Recreational Vehicles or Modular Construction. The furnaces conform to Part 3280 (a)(2) of HUD Manufactured Homes Construction and Safety Standards. They must be installed only with listed RJ-Roof Jack, Sealed Combustion venting system.

NOTE: These instructions are intended to assist qualified individuals experienced in the installation of heating equipment.

Some state and local codes require installation personnel to be licensed. Read all instructions before starting the installation.

### SAVE THIS MANUAL

NOTICE – Furnace set-up and any adjustment needed is responsibility of the installer/retailer/ contractor and is not covered by the furnace manufacturers warranty.

### CHECKLIST: FURNACE START-UP

1. Has furnace roof jack crown been correctly installed.
2. Has the furnace gas valve and burner orifice been cleaned.
3. Is the gas line outlet pressure set for the fuel used.
4. If the home uses a crossover air connector duct, is it installed per homebuilders installation instructions.
5. Has furnace been operated through complete heating cycle.

80 AFUE - AUTOMATIC HOT SURFACE IGNITION

Model No.	G18D060AH2	G18D070AH2	G18D077AH2	G18D090AH2	G18D060CA3	G18D070CA3	G18D077CA3	G18D090CA3	G18D060CA4	G18D070CA4	G18D077CA4	G18D090CA4
Input, BTUH	60,000	70,000	77,000	90,000	60,000	70,000	77,000	90,000	60,000	70,000	77,000	90,000
Output, BTUH	48,000	56,000	61,600	72,000	48,000	56,000	61,600	72,000	48,000	56,000	61,600	72,000
AFUE, %	80	80	80	80	80	80	80	80	80	80	80	80
With A-Coil Cabinet	YES	YES	YES	YES	YES	YES	YES	YES	YES	YES	YES	YES
Ignition Type	Auto-Elect	Auto-Elect	Auto-Elect	Auto-elect	Auto-Elect	Auto-Elect	Auto-Elect	Auto-elect	Auto-Elect	Auto-Elect	Auto-Elect	Auto-elect
Air Temp Rise, Range - F40-70	40-70	40-70	40-70	45-75	40-70	40-70	40-70	45-75	40-70	40-70	40-70	45-75
Designed Max Outlet Air Temp-F170	170	170	170	175	170	170	170	175	170	170	170	175
Natural Gas Orifice Size	27	22	19	17	27	22	19	17	27	22	19	17
Propane (LP) Gas Orifice Size	44	42	41	37	44	42	41	37	44	42	41	37
Blower-Heat or Heat/Cool	10 X 8, 1/4 HP, 2 SPD				10 X 8, 1/3 HP, 3 SPD				10 X 8, 3/4 HP, 4 SPD			
Max. External SP (Duct), In. W.C.	0.3											
Fuel	Natural Gas (Factory Equipped) - LP Orifice Furnished											
High Altitude	For elevations above 2,000 feet, reduce input 4% for each 1,000 ft. elevation above sea level											
Furnace Flue Pipe	Must Use RJS Roof Jack for Sloped Roof or RJF Roof Jack for Flat Roof											
Gas Connection	1/2" FPT											
Electric Service	115 VAC, 60 Hz, 1 PH											
Fuse or Circuit Breaker	15 Amp											
Thermostat Circuit	24 VAC, 60 Hz, 40VA											
Filters	2 - 16" X 20" X 1"											

PRODUCT CODE

G	18	D	060	A	H	2	A	A
G=Gas	18=80%	D = Downflow U = Upflow	060, 070,077 090 = Heating Input	Cabinet Height A = 56" C = 77.5"	Furnace Configuration H = Heating Only A = Heating And A/C Ready	Indoor Blower Air Flow (Ton)  2 = 2 SPD 1/4 HP Motor 3 = 3 SPD 1/3 HP Motor 4 = 4 SPD 3/4 HP Motor 5 = 5 SPD 3/4 HP Motor	Type Of Blower Motor  A = PSC Motor	Revision Letter  A

ACCESSORIES

PART NO.	DESCRIPTION	NOTES
90-RJF1729-AL	Body, Roof Jack, Gas-FLAT	Height 94 1/2 X 106 1/2
90-RJF2551-AL	Body, Roof Jack, Gas-FLAT	Height 102 1/2 X 128 1/2
90-RJS1729-AL	Body, Roof Jack, Gas-SLOPE 3/12	Height 94 1/2 X 106 1/2
90-RJS2551-AL	Body, Roof Jack, Gas-SLOPE 3/12	Height 102 1/2 X 128 1/2
90-RJS3868-AL	Body, Roof Jack, Gas-SLOPE 3/12	Height 115 1/2 X 145 1/2
90-RJS6399-AL	Body, Roof Jack, Gas-SLOPE 3/12	Height 140 1/2 X 176 1/2
90-RJCRWN-AL	Crown, Roof Jack, Gas	Use w/Gas Roof Jack Body
90-TRN-RNG	Ceiling Trim Ring, Roof Jack	Trim out to inside RJ - Pipe
RJTRC	Kit, Transit - Roof Jack -- Cap & Label	For transport-Remove on site
90-OUTXT16-AL	Roof Jack Outdoor Extension - Gas 16"	Extend pipes / crown - 16 in.
90-INXST10-AL	Roof Jack Indoor Extension - Gas 10"	Extend pipes / crown - 10 in.
90-RJS56	5-6/ 12 Slope, Roof Saddle Adapter	Add to RJS 3/12 Roof Jack
90-DCU0-01	86AA0013 Duct Conn + 87FB0005 Flr Base	Floor to Duck 1 in. - 4 in.
90-DCU0-02	86AA0014 Duct Conn + 87FB0005 Flr Base	Floor to Duck 6 in. - 8 in. STD
90-DCU0-03	86AA0015 Duct Conn + 87FB0005 Flr Base	Floor to Duck 8 in. - 12 in.
90-CABEXT4	White, Top, Cabinet Extender Plate	Fill alcove 76" top opening

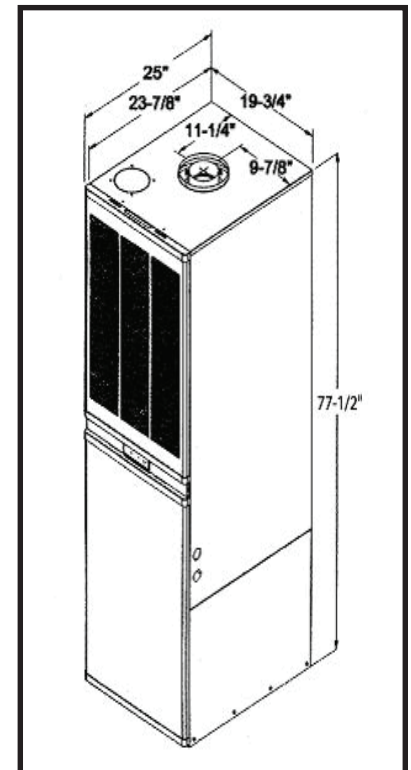



- ❑ **ELECTRIC POWER** - turn off all electrical power to furnace before performing any maintenance or service on unit. Failure to take this precaution may result in personal injury due to electrical shock.
- ❑ **SERVICE** - a qualified service technician should service this unit. Fuel burning appliances can generate toxic flue products. Modification of the appliance can cause carbon monoxide in deadly amounts. To prevent a safety hazard, maintain this appliance in a safe operating manner and do not modify.
- ❑ **DO NOT** modify vent or operate the unit with a blocked vent or inlet air pipe.
- ❑ **DO NOT** re-drill a burner orifice. If the orifice size must be changed, use only a new orifice.
- ❑ **DO NOT** use matches, lighters, candles, or other sources of open flame to check for gas leaks.
- ❑ **PROPER** maintenance for this unit requires certain mechanical skills and tools. If you are at all uncertain, contact your Heating Service Co. for maintenance and service.
- ❑ **CONSULT** with a service technician for any problems or questions you may have pertaining to this appliance.
- ❑ **ALWAYS** inspect the appliance before starting a new heating season, paying special attention to vent pipes and fuel lines.

**NOTE:** The words "Shall" or "Must" indicate a requirement, which is essential to satisfactory and safe furnace performance.

The words "Should" or "May" indicate a recommendation which may be helpful or enhance performance.

**INSTALLATION STANDARDS**

**CODE COMPLIANCE**

The installer shall become familiar with and follow all local codes and regulations which govern the installation of this furnace. Where applicable, local codes may take precedence.

- ❑ Federal Manufactured Home Construction and Safety Standards – HUD Title 24, Part 3280.
- ❑ National Fuel Gas Code – ANSI-Z223.1/NFPA-54
- ❑ Unit electrical wiring and grounding shall comply with National Electrical Code – ANSI/NFPA-70
- ❑ "Manufactured Housing" – NFPA-501 and Fire Safety Criteria for Mobile Home Installations – NFPA 501A
- ❑ "Recreational Vehicles" – ANSI – 119/NFPA – 501C

**HIGH ALTITUDE INSTALLATION**

For elevations above 2,000 feet derate furnace input 4% for each 1,000 feet of elevation above sea level. Furnace deration is accomplished by reducing the burner orifice size. See DERATING CHART for orifice size and CONVERSION INSTRUCTIONS, Page 11.

**INSTALLATION CLEARANCES**

These furnaces are design certified for the following minimum clearances from combustibile materials in alcove or close installations.

Top .....	6 in.
Sides .....	0 in.
Back .....	0 in.
Alcove-front of furnace .....	18 in.
Closet-front of furnace .....	6 in.
Duct .....	0 in.
Vent/Roof Jack .....	0 in.

\* If the return air opening is below the top of the furnace, clearance to the side or rear shall be 6".

\*\* See Return Air for clearances less than 6".

Locate furnace to ensure adequate room for service access to all vent connections, controls and the heat exchanger. A front clearance of 18" minimum (24" recommended) shall be provided by a closet door or spacing away from a facing wall or partition.

For installation on combustibile flooring (except carpeting) using manufacturers supplied floor base P/N 87FB0005 and duct Connector Series P/N 86AA001, included in 90-DCU0-01/03 kits.

**RETURN AIR****ALCOVE INSTRUCTION**

The furnace may be installed free standing or in an alcove with a free flow of air back to the furnace. A minimum of 18" shall be provided at the front for return air and service access.

**CLOSET INSTALLATION – 6 in.**

Note: If return air is through a side wall, there must be a minimum of 6-in. clearance from side wall to furnace in addition to 6-in. minimum clearance from inside of closet door to front of furnace.

If a louvered door complying with the minimum air requirements is used, the front clearance may be reduced to 1".

**CLOSET INSTALLATIONS***Additional Requirements:*

Concerning under floor or ceiling return air systems, the following item (1 – 10) must be adhered to:

1. The return-air opening into the closet, regardless of location, is to be sized not less than specified on the appliance rating plate.
2. If the return-air opening is located in the floor of the closet (versus the vertical front or side wall), the opening is to be provided with means to prevent its inadvertent closure by a flat object placed over the opening.
3. The cross-sectional area of the return system (when located in the floor or ceiling of the manufactured home) leading into the closet is to be not less than that of the opening specified on the appliances rating plate.
4. The total free area of openings in the floor or ceiling registers serving the return-air duct system is to be not less than 150% of the size opening specified on the appliance rating plate. At least one such register is to be located where the likelihood of its being covered by carpeting, boxes, and other objects is minimized.
5. Materials located in the return duct system have a flame spread classification of 200 or less.
6. Non-combustible pans having one-inch upturned flanges are located beneath openings in the floor return duct system.

7. Wiring materials located in the return duct system conform to Article 300-22 (B&C) of the National Electric Code, ANSI / NFPA-70.
8. Gas piping is not run in or through the return duct system.
9. The negative pressure in the closet, as determined by test with the air-circulating fan operating at high heating speed and the closet door closed, is to be not more negative than minus 0.05-inch water column.
10. For floor return systems, the manufactured home manufacturer or installer shall affix a prominent warning where it is easily read when the closet door is open.

**WARNING****HAZARD OF ASPHYXIATION**

**DO NOT COVER OR RESTRICT**  
**FLOOR OPENING, or equivalent**

**RETURN AIR**

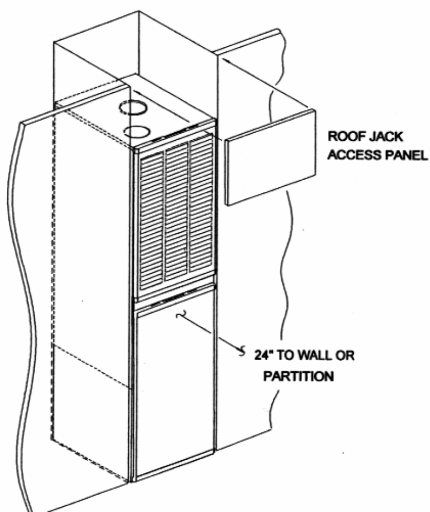

**ALCOVE INSTALLATION**

**ALCOVE**

A minimum of 18" front clearance to a facing wall or partition is needed for service access and return air.

Provide a removable panel above the furnace for access to roof jack and pipe connections on top of the furnace.

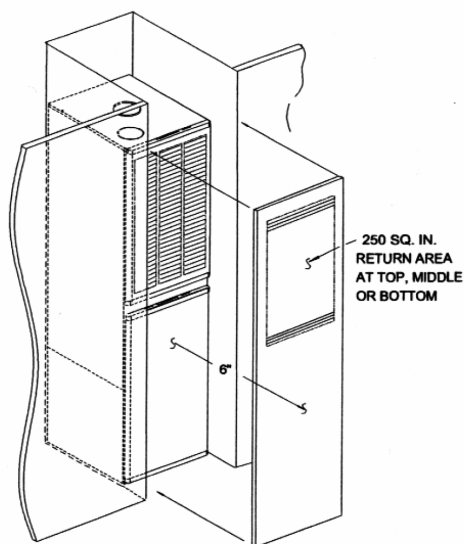

**CLOSET INSTALLATION**

**CLOSET - 6" CLEARANCE**

A minimum of 250 sq. in free open area return opening is required to the closet. The return opening may be anywhere on or above the closet door. If the return is through a side wall, and the opening is below the top of the furnace, a minimum of 6-in. clearance from side wall to furnace must be provided in addition to 6-in minimum clearance from inside of closet door to furnace.

If a 5T A/C will be installed, the return shall be increased to 390-sq. in. open area.

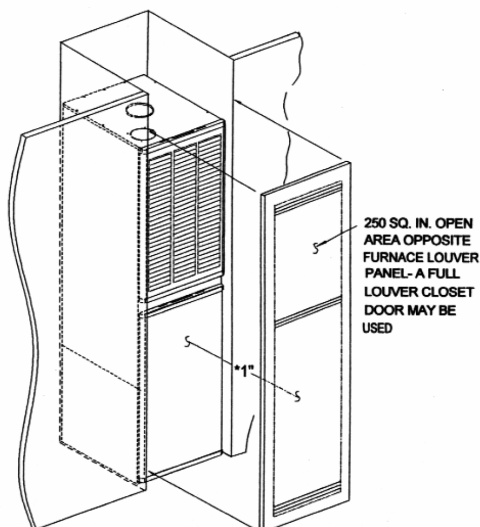

**\*SPECIAL - 1"- 6" CLOSET INSTALLATION**

**SPECIAL-CLOSET, 1" CLEARANCE**

For closet installations with less than 6-in. clearance from inside of closet door to furnace, a louvered closet door must be used with a min. of 250 sq. in open area directly in line with the furnace top louver panel as shown. A fully louvered closet door may be used.

If a 5T A/C will be installed, the return shall be increased to 390 sq. in open area directly in line with the furnace louver panel.

**AIR DISTRIBUTION SYSTEMS**

The supply duct system must be designed so that static pressure in the duct does not exceed the static pressure listed on the furnace rating plate. Location, size and number of registers should be selected on the basis of best air distribution and floor plan of the home. A manual to review before selecting a duct system is Manufactured Housing Duct Systems: Guide to Best Practices by Manufactured Housing Research Alliance (MHI-MHRA).

Typical duct systems are shown below: FIG. A, B, C

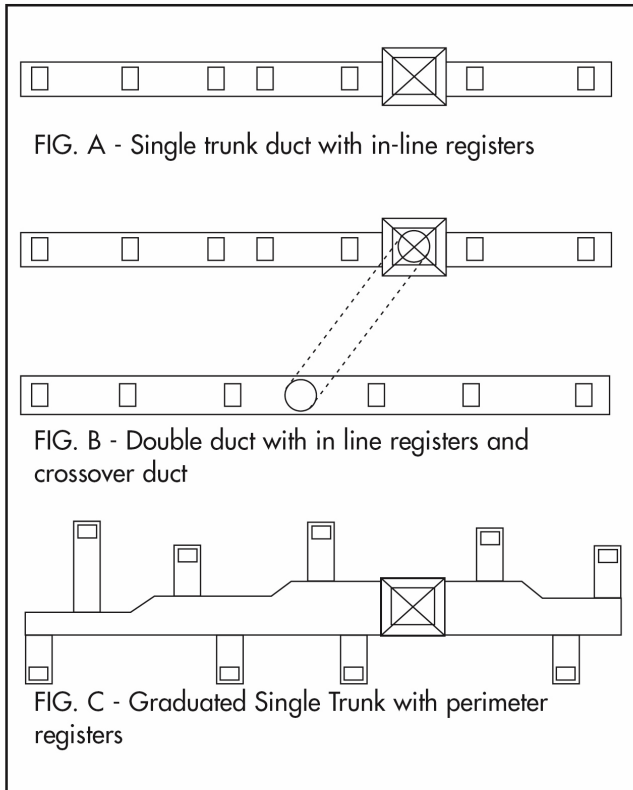

**DUCT CONNECTOR / BASE INSTALLATION**

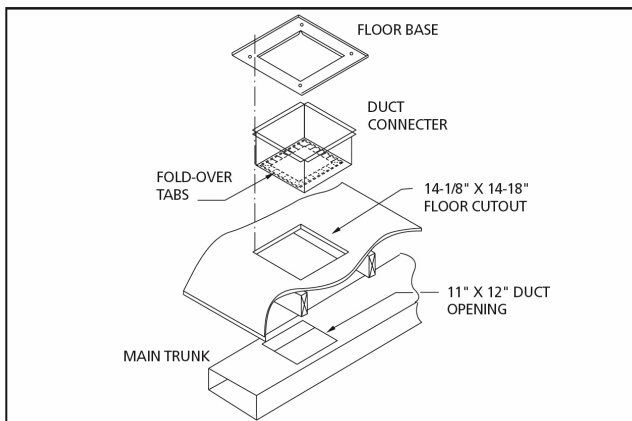

The furnace may be on combustible flooring (expect carpeting) when installed with 86AA001- Duct Connector and 87FB0005 Floor Base.

1. Cut a 14-1/8 x 14-1/8 opening in floor. Fig. D.

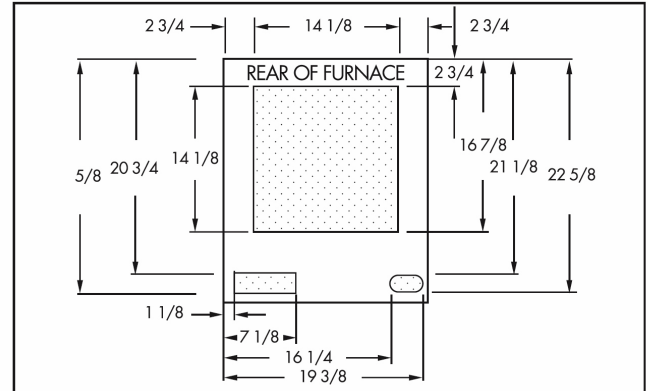

FIG.D Duct Connector Opening, Fuel & A/C Lines

2. Orient duct connector to align 11x13 tabbed opening with floor duct. See FIG. E

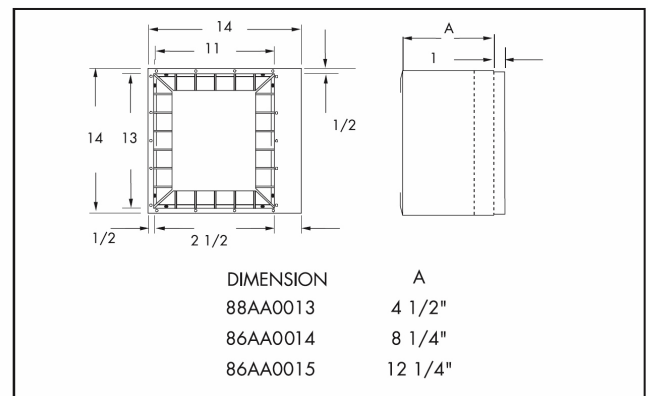

FIG. E- 86AA001- Duct Connector

1. Place duct connector tab end down, thru floor opening to rest on top duct surface.
2. Use eight (8) oval holes on tab surfaces as locators and mark for 11x13 duct opening; remove duct connector.
3. Connect marks with straight lines and cut out the duct opening slightly outside the lines.
4. Attach four (4) foam tape gaskets (provided) to duct connector alongside tabs for a 11x13 perimeter seal.
5. Replace duct connector/gaskets through floor opening.
6. Bend tabs down into the duct opening and fold back 180 degrees, securing duct connector. Add screws if needed.
7. Slit the 4 corners of the connector extending above the floor. Bend sides over onto the floor surface. Fig. F
8. Install floor base over floor opening with 13x13 flanges down. Nail to floor thru 4 holes. Fig. G

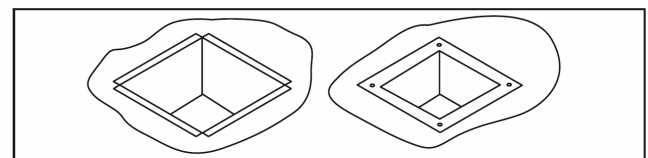

FIG. F

FIG. G

**INSTALL FURNACE**

Prior to installing furnace, fuel and A/C line opening may be cut in. See Fig. D

1. Remove upper and lower furnace doors.
2. Slide furnace onto floor base and push back until cabinet is against rear flange of floor base.
3. Secure furnace to floor with fasteners such as screws at right and left front inside corners of cabinet.
4. Attach pipe strap at top of furnace to alcove or closet framing, or fasten through furnace front edge cabinet sides to wood framing.

**RJ — SERIES ROOF JACK**

G18D's are sealed combustion furnaces tested and listed for use ONLY with RJ — Series Roof Jack Venting System. Furnace exhaust gases vent outdoors through the inner pipe of the RJ — Series "pipe-within-a-pipe" vent system. The space between the outer and inner pipes is used to bring in outside combustion air for the burner.

**WARNING**

**Do not install furnace with any other type of venting system. A HAZARDOUS CONDITION MAY RESULT.**

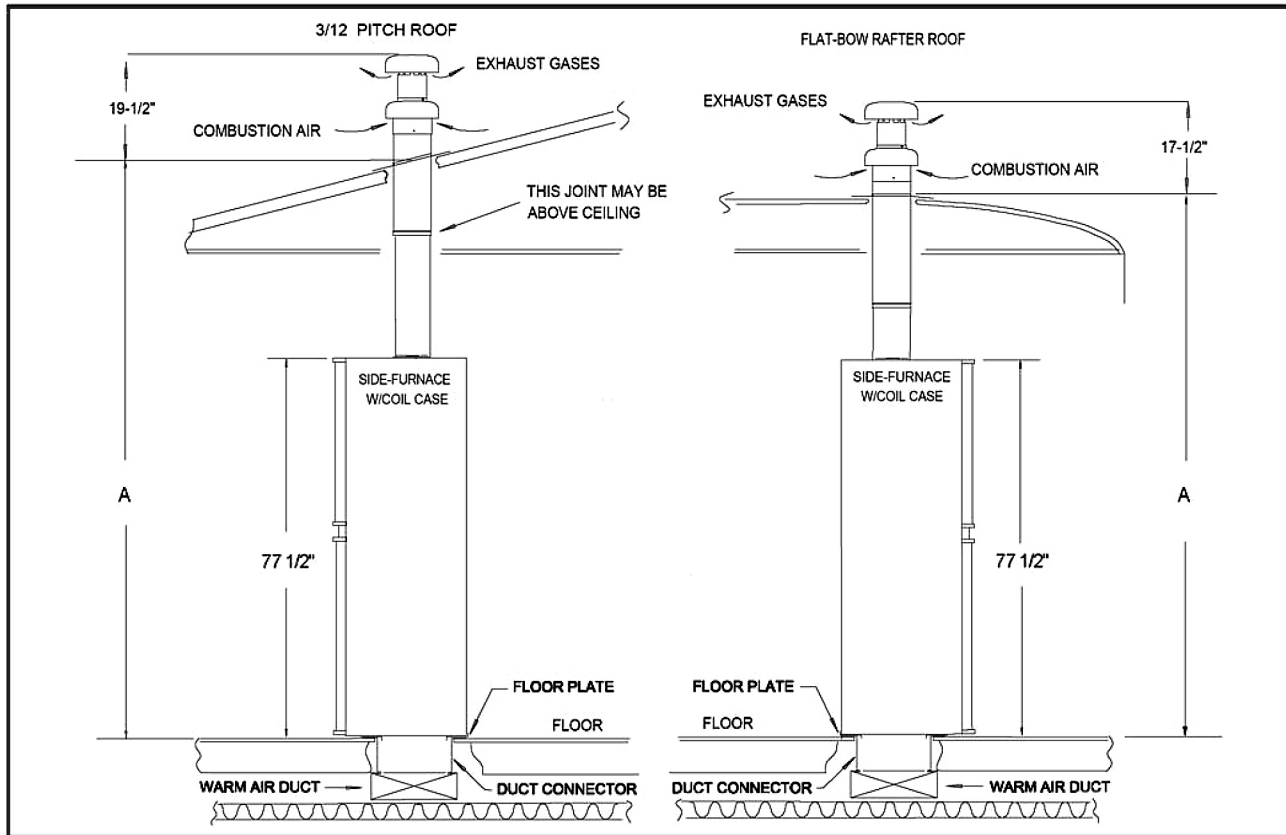

THE SEALED COMBUSTION VENT SYSTEM CONSISTS OF: ROOF JACK BODY AND ROOF JACK CROWN			FURNACE SERIES G18D-A, 56" H	FURNACE SERIES G18D-C, 77 1/2" H
PART NO. ROOF JACK BODY	TELESCOPING RANGE	FOR: FLAT OR SLOPED ROOF	"A" ADJUSTABLE HEIGHT	"A" ADJUSTABLE HEIGHT
90-RJF1729-AL	17" - 29"	FLAT	73" - 85"	94 1/2" - 106 1/2"
90-RJF2551-AL	25" - 51"	FLAT	81" - 107"	102 1/2" - 128 1/2"
90-RJS1729-AL	17" - 29"	3/12	73" - 85"	94 1/2" - 106 1/2"
90-RJS2551-AL	25" - 51"	3/12	81" - 107"	102 1/2" - 128 1/2"
90-RJS3868-AL	38" - 68"	3/12	94" - 124"	115 1/2" - 145 1/2"
90-RJS6399-AL	63" - 99"	3/12	119" - 155"	140 1/2 - 176 1/2"
PART NO. ROOF JACK CROWN		MUST USE WITH:		
90-RJCRWN-AL		ROOF JACK BODY		

## CUTTING ROOF JACK OPENING

A proper installation of the roof jack requires that openings in roof and ceiling be on the same vertical centerline as the furnace flue collar. See FIG. 1

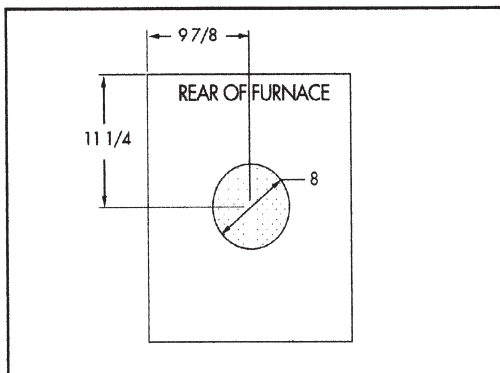

FIG. I - ROOF CUT-OUT

Mark the center point on the ceiling and scribe a 4" radius (8" diameter) around this mark. If furnace is in place during this step, cover the furnace and flue opening to prevent debris from entering flue.

## INSTALLING ROOF JACK

The roof jack body should be secured to the furnace before the roof flashing is secured to the roof.

1. Insert roof jack body into opening in the roof.
2. From above, center the roof jack body aligning with the furnace collar.
3. From inside the home, pull down 4-3/16" D flue pipe seating the pipe fully and firmly over the furnace flue collar.
4. Next pull down the 7" D combustion air pipe seating it over the mating furnace collar. Rotate the combustion air pipe lining up to the screw hole on the 7" collar.
5. Check and make sure the combustion air pipe is fully seated. Then drive a # 10 sheet metal screw, attaching pipe firmly to furnace collar.
6. Install optional ceiling trim ring, 90-TRM-RNG.
7. On the roof, caulk liberally under the roof jack flashing.
8. Drive nails or screws through the flashing onto the roof surface about 1 - 1 1/2" apart. Caulk again to ensure a leak tight joint.
9. Install roof jack crown and fasten to roof jack body with three (3) screws (provided) using pre-punched holes.

## INSTALLATION IN SNOW REGIONS

When the combustion air inlet to the roof jack is blocked with snow, the furnace will not operate properly due to the depleted combustion air supply.

Therefore, if the furnace will be located in regions where snow accumulation on the roof exceeds 7" or in H.U.D. Snow Load Zones, a roof jack extension - Part5 No. 90-OUTXT16-AL is recommended.

## ROOF JACK ON HI-PITCH ROOF

To install the RJS (3/12) Series Roof Jack on roofs which have a slope between 4.5/12 - 6/12, install a Part No. 90-RJS56 Roof Saddle, FIG. J. The combined assembly of the RJS Roof Jack and Roof Saddle will conform to the higher roof pitch. If roof pitch is greater than 6/12, field fabricate a suitable adapter, or consult with factory.

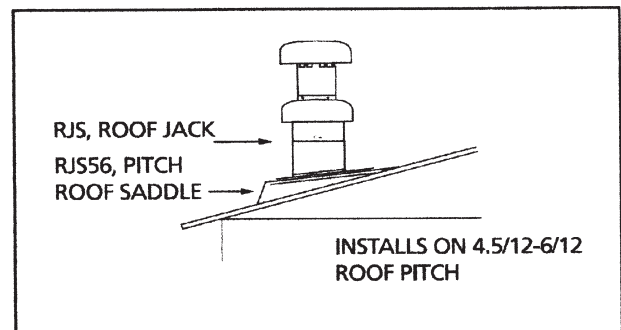

FIG. J - 90-RJS56 ROOF SADDLE, HI PITCH ROOF



**WARNING**

To avoid electric shock, personal injury, or death, turn off the power at the disconnect or the main service panel before making any electrical connections.

**CONNECT POWER SUPPLY**

1. Remove the furnace control panel cover.
2. Insert 115 V wiring through a strain relief bushing on the left side of the furnace.
3. Connect the HOT wire to the black pigtail lead; connect the NEUTRAL wire to the WHITE pigtail lead. Secure the connections with suitable wire nuts and wrap with electrical tape. Refer to Wiring Diagram on Pg. 12 for connections.
4. Connect the GROUND wire to a grounding screw in the control panel.
5. Reinstall and secure the control panel cover with screws.

**WALL THERMOSTATE**

The location of the wall thermostat is important, as it must sense the desired temperature of the entire conditioned space. Choose a location 4–5 feet above the floor, preferably on an inside wall in an area with good air circulation. Stay away from lamps and air registers and do not install behind a door. Choose a location where the temperature will be reasonably representative of other living areas the thermostat is controlling.

**CONNECT THERMOSTAT WIRES**

When installing a furnace with a cooling coil compartment, use of a five-connector thermostat cable is recommended. This will allow easy installation of an air conditioning system at a later date.

1. Insert 24V wires through the small plastic bushing on the left side of the furnace.
2. Connect low voltage wires to the color coded low voltage pigtails at the of the control panel.
3. Connect low voltage wires to the wall thermostat.

NOTE: The use of 18-gauge wire is highly recommended to carry the thermostat load. Use of smaller conductors risks operational problems caused by loose or broken conductors or wire that is too small to carry the load. Any such problems are the responsibility of the installer.

With conductors smaller than 18-gauge, observe the following guidelines.

Maximum Thermostat wire Length (furnace to thermostat)	Thermostat wire gauge
0–120 feet	18
0–70 feet	20

**GAS PIPING**

Supply piping must be sized in accordance with recommendations found in National Fuel Gas Code ANSI Z223.1/NFPA-54. In addition materials used in manufactured homes must comply with requirements contained in HUD Title 24, Section 3280.705 as well as A119.2 for recreational vehicles.

See Chart in this manual for minimum sizes for NAT and LP pipe and tubing serving the furnace only.

NOTE: The gas inlet on the gas control valve is 1/2-14NPT. The gas line may be installed through the bottom casing or on left or right side of furnace.

**WARNING**

Take care when connecting the gas line to the furnace gas valve. Use suitable wrenches to support the gas valve when tightening fittings to prevent mis-alignment of the attached burner orifice. Do not damage the gas valve as improper heating, explosion, fire or asphyxiation may result.

Do not use matches, lighters, candles or other open flame to check for leaks. Use soap or water solution or a leak detector.

Do not test the fuel system at more than 14" W.C. pressure once furnace has been connected to the gas line. Over pressure may void the warranty and damage the valve which could cause an explosion, fire or asphyxiation.

**GAS PRESSURE**

TYPE GAS	INLET GAS PRESSURE	PRESSURE TO BURNER
Natural	7" W.C.	3-1/2" W.C.
Propane	11" W.C.	10" W.C.

**GAS PIPE AND TUBING—MIN SIZES**

MODEL	TYPE	LENGTH	PIPE	TUBING
MGD	OF		SIZE	SIZE
	GAS	(FT.)	(IN.)	(IN. OD)
60	Natural	to 20	1/2	5/8
		to 60	1/2	-
	Propane	to 70	-	3/4
		to 40	1/2	-
70	Natural	to 70	-	5/8
		to 80	1/2	-
		to 20	-	5/8
	Propane	to 50	1/2	-
		to 60	-	3/4
		to 80	3/4	-
77	Natural	to 30	1/2	-
		to 60	-	5/8
		to 80	1/2	-
	Propane	to 30	1/2	-
		to 60	-	5/8
		to 80	1/2	-
90	Natural	to 40	1/2	3/4
		to 50	-	3/4
		to 30	1/2	-
	Propane	to 40	-	5/8
		to 60	1/2	3/4
		to 40	-	5/8



**WARNING**

When converting gas control valve from or to Propane gas, it will be necessary to change the main burner orifice to prevent an underfired or overfired condition. The pressure regulator on the gas control valve must also be converted. See label on lower furnace compartment for full instructions.

If the gas input to the furnace is too high due to excessive pressure, wrong size burner orifice, no orifice, high altitude, etc., the burner flame will be sooty especially with Propane gas. This type of furnace operation can produce carbon monoxide, which could result in unsafe operation, explosion, and/or fire and asphyxiation.

**Operation** — Once system gas piping has been checked for leaks, operation the furnace using the lighting instructions on the front furnace panel, and:

1. Observe burner through viewport and make sure it ignites. The color of the flame when operating on natural gas will burn blue with yellow tips. On Propane, a significantly yellow flame can be expected. If flame is not the proper color call a qualified service technician for service.
2. Let furnace operate until blower cycles on. This takes about 2 to 2 1/2 minutes.
3. Turn thermostat down.
4. Observe burner to make sure it has shut off.
5. Let furnace cool and blower cycle off.



**WARNING**

*Should overheating occur, or the gas supply fail to shut off, shut off the manual gas valve to the furnace and allow burner to run until furnace cools down and blower shuts off before shutting off electrical supply.*

**GAS VALVE CONVERSION INSTRUCTIONS**

1. Follow instructions "TO TURN OFF GAS TO APPLIANCE"
2. Remove two bolts securing the gas valve bracket. Pull gas valve valve bracket and burner orifice holder exposing the main burner orifice.
3. Install burner orifice specified on the rating plate for the desired gas.  
Conversion parts are in a bag attached to the gas valve.
4. Replace valve, bracket/orifice holder, and bolts.  
Attach ID tag for the desired gas adjacent to the gas valve.  
Ensure that all connections are tight.
5. Unscrew and reverse the pressure regulating cap so the name of the desired gas is closest to the valve. See illustration.

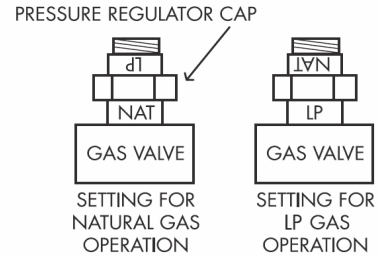

**HIGH ALTITUDE DERATE CHART - MAIN BURNER ORIFICE SIZE**

NATURAL GAS												
ELEVATION	60,000 BTU FURNACE			70,000 BTU FURNACE			77,000 BTU FURNACE			90,000 BTU FURNACE		
	PART NO	ORIF DIA	DRILL SIZE	PART NO	ORIF DIA	DRILL SIZE	PART NO	ORIF DIA	DRILL SIZE	PART NO	ORIF DIA	DRILL SIZE
SEA LEVEL	75AG-144	0.144	27	75AG-157	0.157	22	75AG-166	0.166	19	75AG-173	0.173	17
2000	75AG-1405	0.1405	28	75AG-154	0.154	23	75AG-161	0.161	20	75AG-1695	0.1695	18
3000	75AG-1405	0.1405	28	75AG-152	0.152	24	75AG-161	0.161	20	75AG-166	0.166	19
4000	75AG-136	0.136	29	75AG-1495	0.1495	25	75AG-159	0.159	21	75AG-166	0.166	19
5000	75AG-136	0.136	29	75AG-147	0.147	26	75AG-157	0.157	22	75AG-161	0.161	20
6000	75AG-136	0.136	29	75AG-144	0.144	27	75AG-154	0.154	23	75AG-159	0.159	21
7000	75AG-1285	0.1285	30	75AG-144	0.144	27	75AG-1495	0.1495	25	75AG-157	0.157	22
8000	75AG-1285	0.1285	30	75AG-1405	0.1405	28	75AG-147	0.147	26	75AG-154	0.154	23
9000	75AG-1285	0.1285	30	75AG-136	0.136	29	75AG-144	0.144	27	75AG-152	0.152	24
10000	75AG-120	0.120	31	75AG-136	0.136	29	75AG-1405	0.1405	28	75AG-147	0.147	26

PROPANE (LP) GAS												
ELEVATION	60,000 BTU FURNACE			70,000 BTU FURNACE			77,000 BTU FURNACE			90,000 BTU FURNACE		
	PART NO	ORIF DIA	DRILL SIZE	PART NO	ORIF DIA	DRILL SIZE	PART NO	ORIF DIA	DRILL SIZE	PART NO	ORIF DIA	DRILL SIZE
SEA LEVEL	75AG-086	0.086	44	75AG-0935	0.0935	42	75AG-096	0.096	41	75AG-104	0.104	37
2000	75AG-082	0.082	45	75AG-0935	0.0935	42	75AG-0935	0.0935	42	75AG-1015	0.1015	38
3000	75AG-082	0.082	45	75AG-089	0.089	43	75AG-0935	0.0935	42	75AG-0995	0.0995	39
4000	75AG-082	0.082	45	75AG-089	0.089	43	75AG-0935	0.0935	42	75AG-0995	0.0995	39
5000	75AG-081	0.081	46	75AG-089	0.089	43	75AG-089	0.089	43	75AG-098	0.098	40
6000	75AG-0785	0.0785	47	75AG-086	0.086	44	75AG-089	0.089	43	75AG-096	0.096	41
7000	75AG-0785	0.0785	47	75AG-086	0.086	44	75AG-086	0.086	44	75AG-0935	0.0935	42
8000	75AG-076	0.076	48	75AG-082	0.082	45	75AG-086	0.086	44	75AG-0935	0.0935	42
9000	75AG-076	0.076	48	75AG-081	0.081	46	75AG-082	0.082	45	75AG-089	0.089	43
10000	75AG-073	0.073	49	75AG-0785	0.0785	47	75AG-081	0.081	46	75AG-089	0.089	43

Table shows 4% Input Reduction per 1,000 feet elevation  
 Reference: NFPA No. 54, ANSI Z 223.1 National Fuel Gas Code  
 For canadian High Altitude (2,000-4,500 feet), reduce gas pressure to burner manifold (manifold Ps.) to 3.0" W.C. and 9.0 W.C. for LP (Propane) Gas

**HIGH ALTITUDE ORIFICE CONVERSION KITS**

KIT PART NUMBER	ALTITUDE	FURNACE INPUT
G18HA0601	0 - 5000 FT	60,000
G18HA0602	6,000 - 10,000 FT	60,000
G18HA0701	0 - 5000 FT	70,000
G18HA0702	6,000 - 10,000 FT	70,000
G18HA0771	0 - 5000 FT	77,000
G18HA0772	6,000 - 10,000 FT	77,000
G18HA0901	0 - 5000 FT	90,000
G18HA0902	6,000 - 10,000 FT	90,000

**IF FURNACE FAILS TO OPERATE PROPERLY:**

1. Check setting on wall thermostat and the position of the HEAT-COOL switch if air conditioning is installed.
2. Check to make sure that electrical power is on at the furnace and the furnace breaker has not tripped.
3. Make sure that the filters are clean and return grills are not obstructed. The supply registers should be open.
4. Be sure that the furnace flue and inlet piping has not been obstructed and is open. If the cause for failure is not obvious, do not attempt to service the furnace yourself. Call a qualified service agency or the gas supplier.

**FINAL PROCEDURE****INSTALL FURNACE DOOR PANELS**

A. Install the lower door panel by engaging 2 tabs on bottom cabinet pan into slots on plastic end cap. Then, push in top of door panel until clips on the center divider panel are engaged with latches on door.

B. Install the upper louver door panel in a similar manner, by first engaging tabs on the center divider and then pushing the panel in to engage the clips at top of the cabinet.

**FINISH AND TRIM**

The alcove or closet installation may be finished and trimmed out as needed.

**AIR CONDITIONING SYSTEMS**

If an air conditioning system is installed which does not use the blower for air distribution and operates completely independent of the furnace, the thermostat system shall include interlock, which prevents simultaneous operation of the furnace and air conditioner. An interlock system typically contains a switch, which must be turned to either HEAT or COOL to activate either heating or cooling operation. A cooling thermostat may include a positive OFF switch for this purpose.

When used in connection with a cooling unit the furnace shall be installed parallel with or on the upstream side of the cooling unit to avoid condensation in the heat exchanger. For installations with a parallel flow arrangement, the furnace must be equipped with a damper or other means to prevent cold air from being discharged up around the heat exchanger.

**G18D BLOWER PERFORMANCE CHART**

		ESP INCHES WC DUCT				
CONFIGURATION	SPD TAP	0.1	0.2	0.3	0.4	0.5
<b>H2/10 OR AH2AA BLOWER - 10 X 8 WHEEL 1/4 HP 2 SPD MOTOR</b>						
CFM-NO-COIL	LO	940	885	835	780	725
	HI	1225	1165	1110	1030	970
CFM-WITH-COIL	LO	865	825	775	730	670
	HI	1105	1050	1010	930	870
<b>A3/12 OR BA3AA BLOWER - 10 X 8 WHEEL 1/3 HP 3 SPD MOTOR (Accessory PN 87-1008-312A1)</b>						
CFM-NO-COIL	LO	980	950	910	875	825
	MED	1220	1170	1120	1065	1015
	HI	1460	1400	1340	1270	1195
CFM-WITH-COIL	LO	945	905	865	815	775
	MED	1130	1085	1030	970	905
	HI	1300	1240	1180	1105	1085
<b>A4/16 OR CA4AA BLOWER - 10 X 8 WHEEL 3/4 HP 4 SPD MOTOR (Accessory PN 87-1008-316A1)</b>						
CFM-NO-COIL	LO	995	960	915	875	825
	MED	1205	1165	1130	1090	1045
	MED-HI	1470	1425	1385	1345	1310
	HI	1810	1765	1720	1680	1635
CFM-WITH-COIL	LO	950	905	885	835	790
	MED	1145	1115	1080	1035	1000
	MED-HI	1375	1345	1315	1280	1245
	HI	1700	1660	1620	1575	1540

**WIRING DIAGRAM, G18D**

BLOWER SPEED CHART  
(CHARTÉ DE VITESSE  
DE LA SOUFFLERIE)

INPUT (ENTRÉE)	COOL (CLIM)	HEAT (CHAU)
080	BLK (NOIR)	RED (ROUGE)
070	BLK (NOIR)	GRN (VERT)
077	BLK (NOIR)	RED (ROUGE)
090	BLK (NOIR)	RED (ROUGE)

WIRE COLOR KEY  
(CODE DE COULEUR  
DU FILAGE)

BLK	BLACK (NOIR)
BLU	BLUE (BLEU)
BRN	BROWN (MARRON)
GRN	GREEN (VERT)
ORNG	ORANGE (ORANGE)
RED	RED (ROUGE)
WHT	WHITE (BLANC)
YEL	YELLOW (JAUNE)
BLU	BLUE (BLEU)
GRN	GREEN (VERT)
ORNG	ORANGE (ORANGE)
RED	RED (ROUGE)
WHT	WHITE (BLANC)
YEL	YELLOW (JAUNE)
BLU	BLUE (BLEU)
GRN	GREEN (VERT)
ORNG	ORANGE (ORANGE)
RED	RED (ROUGE)
WHT	WHITE (BLANC)
YEL	YELLOW (JAUNE)

- CAUTION -  
OUVREZ LES DISJONCTEURS AVANT  
DE PROCÉDER AVEC LE SERVICE

- PRECAUTION -  
OUVREZ LES DISJONCTEURS AVANT  
DE PROCÉDER AVEC LE SERVICE

**FLASH CODES**

- STEADY ON  
NORMAL OPERATION
- 1 FLASH -  
IGNITION FAILURE
- 2 FLASHES -  
COMBUSTION AIR  
SWITCH STUCK CLOSED
- 3 FLASHES -  
COMBUSTION AIR  
SWITCH FAILED TO CLOSE
- 4 FLASHES -  
LIMIT SWITCH OPEN
- 5 FLASHES -  
GAS VALVE ENERGIZED  
WITH NO CALL FOR HEAT
- 6 FLASHES -  
REVERSED POLARITY

80% DOWNFLOW FURNACE  
(FOURNAISE 80%  
VENTILÉE PAR LE BAS)

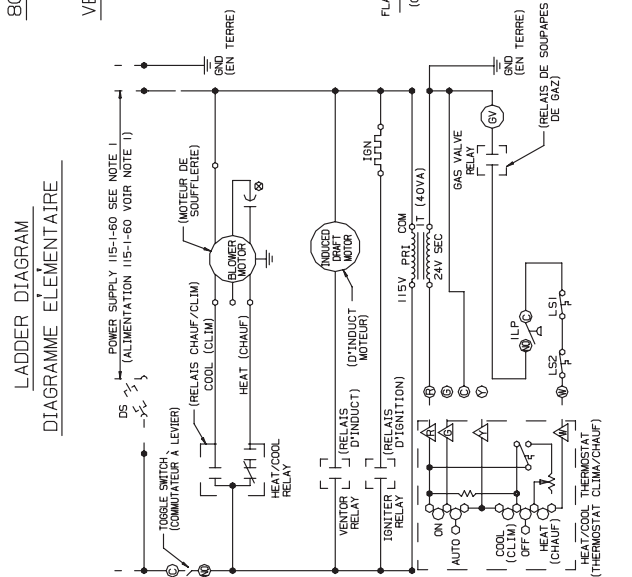

**NOTES:**

1. ALL FIELD WIRING PER (A) NATIONAL WIRE CODE (NEC) AND/OR (B) LOCAL WIRE CODES (CEC) AND/OR (C) LOCAL WIRE CODES.
2. IF ANY OF THE ORIGINAL WIRE AS SUPPLIED WITH THE FURNACE MUST BE REPLACED, IT MUST BE REPLACED WITH WIRING MATERIAL HAVING A TEMPERATURE RATING OF AT LEAST 22 °F (105°C).
3. CONNECTIONS SUITABLE FOR COPPER CONDUCTORS ONLY.
4. ALL REPLACEMENT COMPONENTS MUST BE PROPERLY GROUNDED.
5. PROVIDE DISCONNECTS FOR ALL POWER SUPPLIES.
6. MOTORS ARE INHERENTLY PROTECTED.
7. SSI IS IN SERIES WITH LSI AND LSZ.

**NOTES:**

1. TOUT FILAGE EN CHANTIER SELON: (A) CODE ÉLEC. NATIONAL (N.E.C.) ET/OU (B) CODES LOCAUX ET MUNICIPAUX (C) CODES LOCAUX ET MUNICIPAUX.
2. SI LE FILAGE DOIT ÊTRE REMPLACÉ, IL DOIT ÊTRE REMPLACÉ AVEC UN MATÉRIAU POUVANT RÉSISSER À DES TEMPÉRATURES D'AU MOINS 22°F (105°C).
3. SEULEMENT DES MARIETTES POUR FIL DE CUivre.
4. TOUTE COMPOSANTE DE REMPLACEMENT DOIT ÊTRE BIEN MISE EN TERRE.
5. FOURNISSEZ LES DISJONCTEURS POUR L'ALIMENTATION.
6. LES MOTEURS SONT PROTÉGÉS PAR LEUR CONCEPTION.
7. SSI EST EN SÉRIE AVEC LSI ET LSZ.

CONNECTION DIAGRAM  
(DIAGRAMME DE RACCORDEMENT)

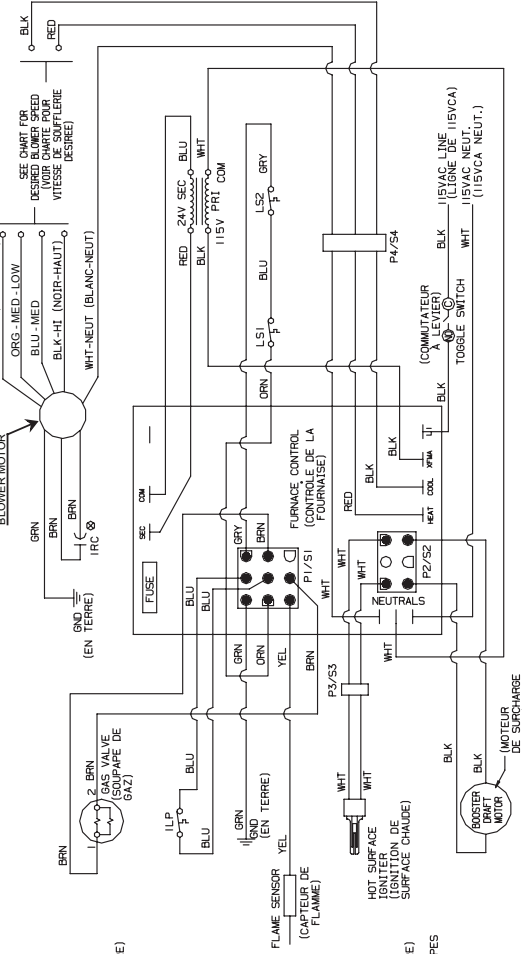

**LEGEND**

- DS DISCONNECT SWITCH
- GV GAS VALVE
- IGN HOT SURFACE IGNITOR
- P1/S1 9 PIN PLUG & SOCKET ON FURNACE CONTROL BOARD
- P2/S2 6 PIN PLUG & SOCKET ON FURNACE CONTROL BOARD
- P3/S3 2 PIN PLUG & SOCKET AT HOT SURFACE IGNITOR
- P4/S4 9 PIN PLUG & SOCKET
- LS1,2 AUXILIARY LIMIT SWITCH ON BLOWER INLET
- ILP PRESSURE SWITCH
- IRC RUN CAPACITOR
- IT TRANSFORMER, 40VA
- IT IDENTIFIED RUN CAPACITOR
- △ 24V CONNECTION ROOM THERMOSTAT
- FIELD CONNECTION
- FACTORY WIRING AND DEVICES
- FIELD WIRING AND DEVICES
- RELAY CONTACTS ON IGNITION CONTROL BOARD

**LEGENDE**

- DS COMMANDEUR DE DISJONCTION
- GV SOUPAPE DE GAZ
- IGN IGNITION DE SURFACE CHAUDE
- P1/S1 PRISE & RECEPTACLE A 9 PTS SUR LA PLAQUETTE DE CONTROLE D'IGNITION
- P2/S2 PRISE & RECEPTACLE A 6 PTS SUR LA PLAQUETTE DE CONTROLE D'IGNITION
- P3/S3 PRISE & RECEPTACLE A 2 PTS D'IGNITION DE SURFACE CHAUDE
- P4/S4 PRISE & RECEPTACLE A 9 PTS
- LS1,2 COMMUNICATEUR AUXILIAIRE DE PRESSION SUR BOTTIER DE SOUFFLERIE
- ILP COMMUNICATEUR DE PRESSION
- IRC CAPACITEUR DE FONCTIONNEMENT IDENTIFIE
- IT TRANSFORMEUR, 40VA
- IT CAPACITEUR DE FONCTIONNEMENT IDENTIFIE
- △ RACCORDEMENT DE 24V
- RACCORDEMENT DE CHANTIER
- FILAGE DE L'USINE ET APPAREILS
- FILAGE DE CHANTIER ET APPAREILS
- CONTACTS DES RELAIS SUR LA PLAQUETTE DE CONTROLE D'IGNITION

**HEAT ONLY MODELS  
UTEAC & TI BOARD WIRING DIAGRAM**

**WIRING DIAGRAM, G18D**

BLOWER SPEED CHART  
(CHARTÉ DE VITESSE  
DE LA SOUFFLERIE)

060	HEAT
060	(CHAUF)
070	COOL
070	(CLIM)
080	HEAT
080	(CHAUF)
090	COOL
090	(CLIM)

WIRE COLOR KEY  
(CODE DE COULEUR  
DU FILAGE)

BLK	BLACK	(NOIR)
BLU	BLUE	(BLEU)
BRN	BROWN	(MARRON)
GRN	GREEN	(VERT)
GRY	GRAY	(GRIS)
OR	ORANGE	(ORANGE)
PUR	PURPLE	(VIOLET)
RED	RED	(ROUGE)
WHT	WHITE	(BLANC)
YEL	YELLOW	(JAUNE)

- CAUTION -  
OPEN ALL DISCONNECTS BEFORE  
SERVICING THIS UNIT

- PRECAUTION -  
OUVREZ LES DISCONNECTS AVANT  
DE PROCÉDER AVEC LE SERVICE

LADDER DIAGRAM  
DIAGRAMME ÉLÉMENTAIRE

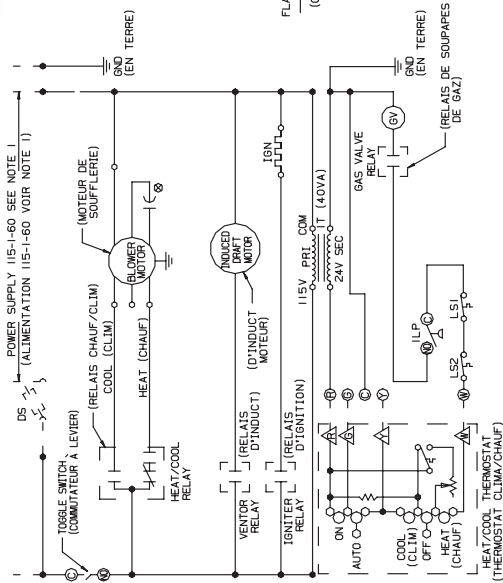

NOTES:

1. ALL FIELD WIRING PER (A) NATIONAL ELEC. CODE (NEC) (ANSI/BR/), (B) CANADIAN ELEC. CODE (CEC) (ANSI/CSA), (C) LOCAL OR CITY CODES.
2. IF ANY OF THE ORIGINAL WIRE AS SUPPLIED WITH THE FURNACE MUST BE REPLACED, IT MUST BE REPLACED WITH THE SAME TYPE AND SIZE OF WIRE.
3. CONNECTORS SUITABLE FOR COPPER COILS AND ALUMINUM TERMINALS ONLY.
4. ALL REPLACEMENT COMPONENTS MUST BE PROPERLY GROUNDED.
5. PROVIDE DISCONNECTS FOR ALL POWER SUPPLIES.
6. MOTORS ARE INHERENTLY PROTECTED.
7. SSI IS IN SERIES WITH LSI AND L52.

NOTES:

1. TOUT FILAGE EN CHANTIER SELON: (A) CODE ÉLEC. NATIONAL (N.E.C.) (ANSI/BR/), (B) CODE ÉLEC. CANADIEN (C.E.C.) (ANSI/CSA), (C) CODES LOCAUX ET MUNICIPAUX.
2. SI LE FILAGE DOIT ÊTRE REMPLACÉ, IL DOIT ÊTRE REMPLACÉ PAR UN MATÉRIAU EQUIVALENT EN TYPE ET EN CALIBRE.
3. SEULEMENT DES MARIAGES POUR FIL DE COPPER ET ALUMINUM SONT PERMIS.
4. TOUTE COMPOSANTE DE REMPLACEMENT DOIT ÊTRE BIEN MISE EN TERRE.
5. FOURNISSEZ LES DISCONNECTS POUR L'ALIMENTATION.
6. LES MOTEURS SONT PROTÉGÉS PAR LEUR CONCEPTION.
7. SSI DE SÉRIE AVEC LSI ET L52.

FLASH CODES

- STEADY ON  
NORMAL OPERATION
- 1 FLASH -  
IGNITION FAILURE
- 2 FLASHES -  
COMBUSTION AIR SWITCH STUCK CLOSED
- 3 FLASHES -  
COMBUSTION AIR SWITCH FAILED TO CLOSE
- 4 FLASHES -  
LIMIT SWITCH OPEN
- 5 FLASHES -  
GAS VALVE ENERGIZED WITH NO CALL FOR HEAT
- 6 FLASHES -  
REVERSED POLARITY

80% DOWNFLOW FURNACE  
(FOURNAISE 80%  
VENTILÉE PAR LE BAS)

CONNECTION DIAGRAM  
(DIAGRAMME DE RACCORDEMENT)

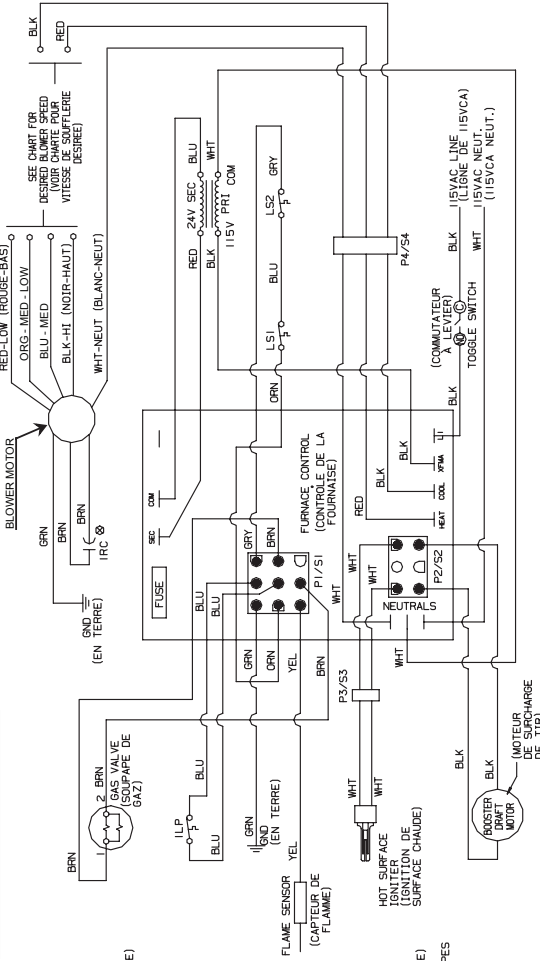

LEGEND

- DS DISCONNECT SWITCH
- GV GAS VALVE
- IGN HOT SURFACE IGNITER
- P1/S1 9 PIN PLUG & SOCKET ON FURNACE CONTROL BOARD
- P2/S2 6 PIN PLUG & SOCKET ON FURNACE CONTROL BOARD
- P3/S3 2 PIN PLUG & SOCKET AT HOT SURFACE IGNITER
- P4/S4 9 PIN PLUG & SOCKET
- L51,2 AUXILIARY LIMIT SWITCH ON BLOWER INLET
- I/LP PRESSURE SWITCH
- IRC RUN CAPACITOR
- IT TRANSFORMER, 40VA
- IDENTIFIED RUN CAPACITOR
- 24V CONNECTION ROOM THERMOSTAT
- FIELD CONNECTION
- FACTORY WIRING AND DEVICES
- FIELD WIRING AND DEVICES
- RELAY CONTACTS ON IGNITION CONTROL BOARD

LEGÈNDE

- DS COMMUTEUR DE DISJONCTION
- GV SOUPAPE DE GAZ
- IGN IGNITION DE SURFACE CHAUDE
- P1/S1 PRISE & RECEPTACLE A 9 PTS SUR LA PLAQUETTE DE CONTRÔLE D'IGNITION
- P2/S2 PRISE & RECEPTACLE A 6 PTS SUR LA PLAQUETTE DE CONTRÔLE D'IGNITION
- P3/S3 PRISE ET RECEPTACLE A 2 PTS D'IGNITION DE SURFACE CHAUDE
- P4/S4 PRISE ET RECEPTACLE A 9 PTS
- L51,2 COMMUTEUR AUXILIAIRE DE PRESSION SUR BOÎTIER DE SOUFFLERIE
- I/LP COMMUTEUR DE PRESSION
- IRC CAPACITEUR DE FONCTIONNEMENT IDENTIFIÉ
- IT TRANSFORMEUR, 40VA
- IDENTIFIÉ CAPACITEUR DE FONCTIONNEMENT IDENTIFIÉ
- 24V RACCORDEMENT DU THERMOSTAT DE PIÈCE
- RACCORDEMENT DE CHANTIER
- FILAGE DE L'USINE ET APPAREILS
- FILAGE DE CHANTIER ET APPAREILS
- CONTACTS DES RELAIS SUR LA PLAQUETTE DE CONTRÔLE D'IGNITION

A/C READY MODELS  
UTEAC & TI BOARD WIRING DIAGRAM



501 Terminal Road • Fort Worth, Texas 76106

817-624-0820

61GF0074