

INSTALLATION INSTRUCTIONS

1.5X4



2X2



2X4



FHSKIT-TXXLNXX or FHSKIT-TXXXHXX

HotSpot1 LED Emergency Kit

Troffer Luminaires



LED EMERGENCY LIGHTING SYSTEM

MANUAL FOR HOTSPOT LED KIT INSTALLATION

TABLE OF CONTENTS

1.0 INSTALLATION INSTRUCTION WARNINGS	PAGE 2
2.0 ORIGINAL FIXTURE PARTS.....	PAGE 3
3.0 HOTSPOT LED KIT PARTS	PAGE 4
4.0 HOTSPOT LED KIT INSTALLATION	PAGES 5-6
5.0 HOTSPOT LED KIT SETUP	PAGES 7-12
6.0 WARRANTY.....	PAGE 13

1.0 INSTALLATION INSTRUCTION WARNINGS

IMPORTANT SAFEGUARDS READ AND FOLLOW ALL SAFETY INSTRUCTIONS.

1. "THIS PRODUCT MUST BE INSTALLED IN ACCORDANCE WITH THE APPLICABLE INSTALLATION CODE BY A PERSON FAMILIAR WITH THE CONSTRUCTION AND OPERATION OF THE PRODUCT AND THE HAZARDS INVOLVED."
2. "WARNING - Risk of fire or electric shock. LED Retrofit kit installation requires knowledge of luminaire electrical systems. If not qualified, do not attempt installation. Contact a qualified electrician."
3. "WARNING - Risk of fire or electric shock. Install this kit only in the luminaires that has the construction features and dimensions shown in the photographs and/or drawings."
4. "WARNING - To prevent wiring damage or abrasion, do not expose wiring to edges of sheet metal or other sharp objects."
5. "WARNING – Risk of fire or electric shock. Luminaire wiring and electrical parts may be damaged when drilling for installation of LED retrofit kit. Check for enclosed wiring and components."
6. "WARNING - Do not mount near gas or electric heaters."
7. "WARNING - Equipment should be mounted in locations and at heights where it will not be subjected to tampering by unauthorized personnel."
8. "WARNING - The use of accessory equipment not recommended by the manufacturer may cause an unsafe condition."
9. "WARNING - Do not use this equipment for other than its intended use."
10. "WARNING - Maximum luminaire mounting height: 10 Feet"

SAVE THESE INSTRUCTIONS.

2.0 ORIGINAL FIXTURE

Intended for the following luminaires:

End View

Side View

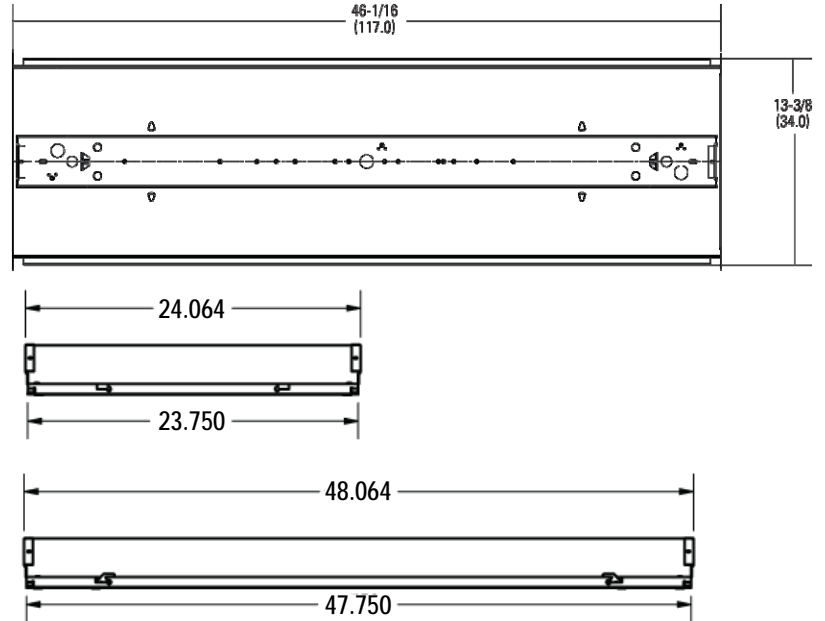
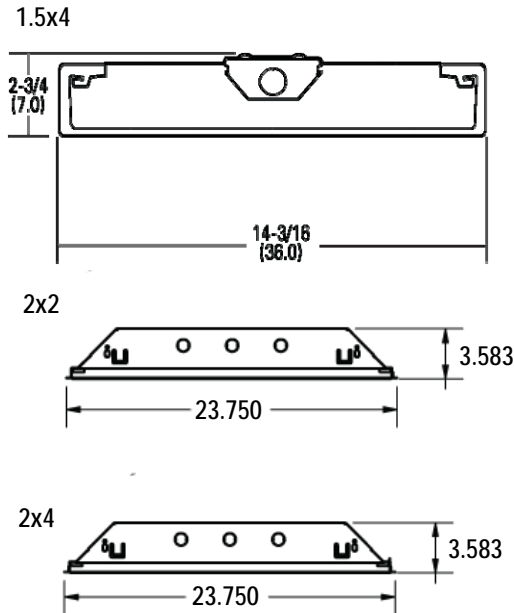

Illustration 1: Luminaire Dimensions

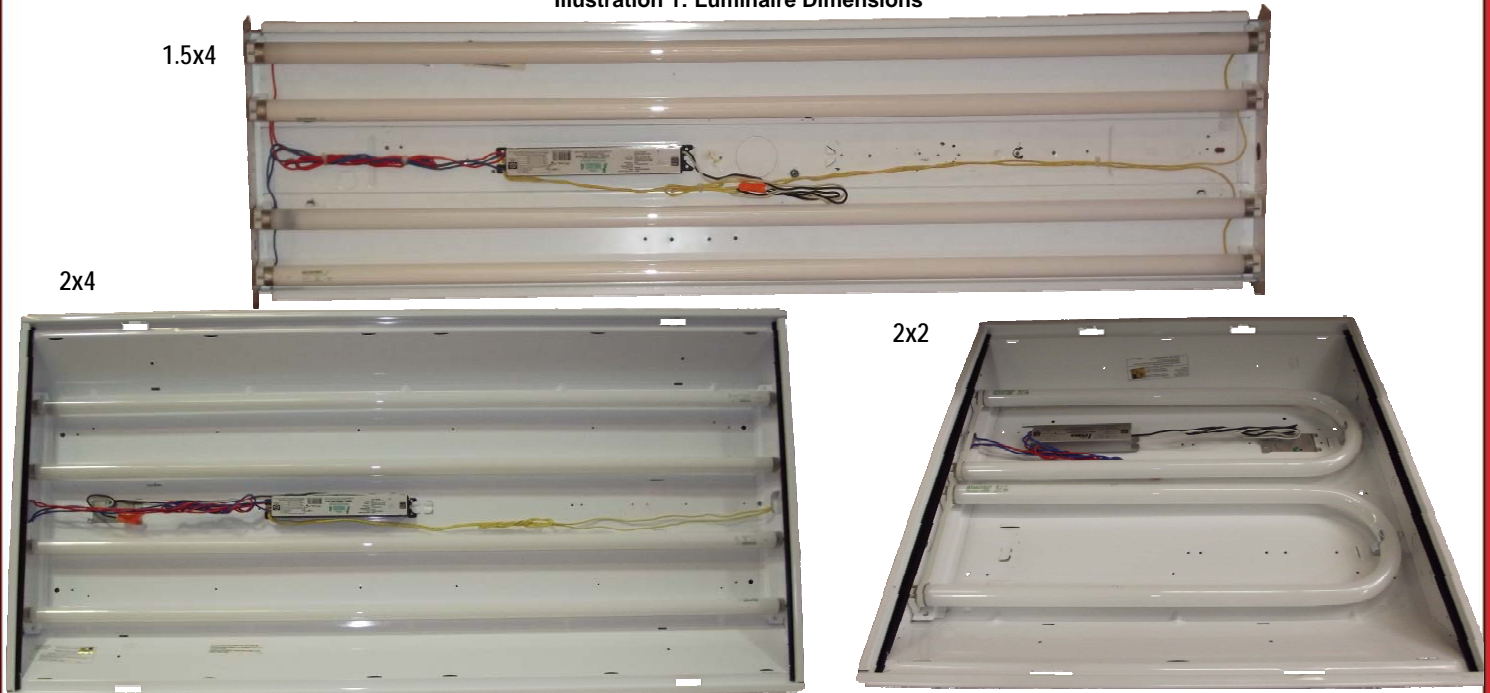

Figure 1: Original Luminaire

NOTE: NOT Suitable for installation in sealed or gasketed compartments

Original Luminaire Disassembly:

- Remove lamps (if installed) and wire-way cover from the luminaire.

3.0 HOTSPOT LED KIT PARTS

A) Hotspot LED Driver



FHS1-UNV-3.6L

B) LED Battery



FHSBATT3-D4



FHSBATT3-C3



FHSBATT3-F7L

C) LED Module



Linear Module
(FHS1-AR-4W-L)

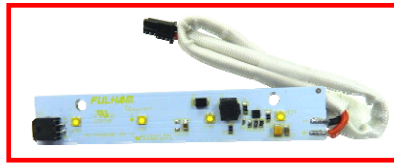

Linear Module w/ multiple connections
(FHS6-AR-3W-L)



"H" Configuration Module
(FHS3-AR-6W-SH), (FHS4-AR-8W-LH)
(FHS3-AR-10W-SH), (FHS4-AR-10W-LH)

D) Hardware: **Screw quantities may change depending on setup**



Figure 2: Hotspot LED Kit Parts

FHSKIT-TXXXXXX LED Kit Parts:

2x4 Troffer

- A) LED Driver: FHS1-UNV-3.6L
 - Battery: FHSBATT3-C3
 - LED Arrays: FHS1-AR-4W-L or FHS3-AR-6W-SH
- B) LED Driver: FHS1-UNV-3.6L
 - Battery: FHSBATT3-F7L
 - LED Arrays: FHS1-AR-4W-L, FHS3-AR-6W-SH, FHS4-AR-8W-LH, FHS3-AR-10W-SH, FHS4-AR-10W-LH, FHS6-AR-3W-L x1, FHS6-AR-3W-L x2, or FHS6-AR-3W-L x3

2x2 Troffer

- A) LED Driver: FHS1-UNV-3.6L
 - Battery: FHSBATT3-C3
 - LED Arrays: FHS1-AR-4W-L or FHS3-AR-6W-SH

1.5x4 Troffer

- A) LED Driver : FHS1-UNV-3.6L
 - Battery: FHSBATT3-C3
 - LED Arrays: FHS1-AR-4W-L
- B) LED Driver FHS1-UNV-3.6L
 - Battery: FHSBATT3-D4
 - LED Arrays: FHS1-AR-4W-L, FHS6-SR-3W-L x1, or FHS6-SR-3W-L x2
- C) LED Driver: FHS1-UNV-3.6L
 - Battery: FHSBATT3-F7L
 - LED Arrays: FHS1-AR-4W-L, FHS6-AR-3W-L x1, FHS6-AR-3W-L x2, or FHS6-AR-3W-L x3

Hardware:

- #6-20x3/8" Phillips Pan Head Self Drilling Screws
- Quantity: 6-10 (Depending on setup)

4.0 HOTSPOT LED KIT INSTALLATION

1. Remove the wire way cover and place the Emergency LED Driver and LED battery pack onto the luminaire's wire-way area. See picture #1.
2. Place the selected LED Module onto the luminaire, in the space between the original lamps. See picture #2.
3. Secure all LED components to the luminaire by using the provided screws.
4. On the already removed wire way cover, drill one 1/2" hole into the luminaire's wire-way cover for the Test Switch. See picture #3. Exact location of the drilled hole can be found on page 12 (LED indicator/test switch must be visible after installation).
5. Insert the Test Switch into the pre-drilled hole in the luminaire's wire-way cover and secure it in place. See picture #3.
6. Connect all LED components based on Illustration #2. For examples of completed installation with wire way please see page 12.

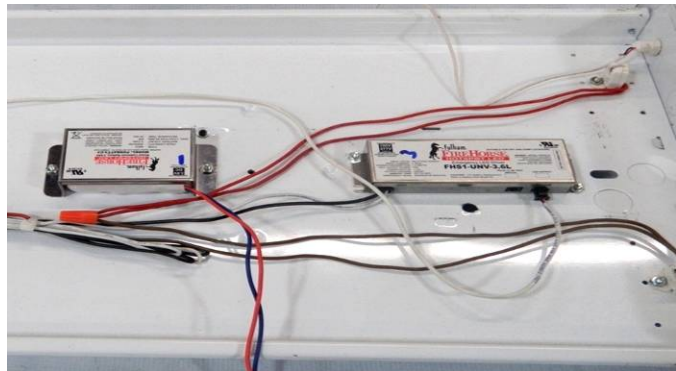

Picture #1

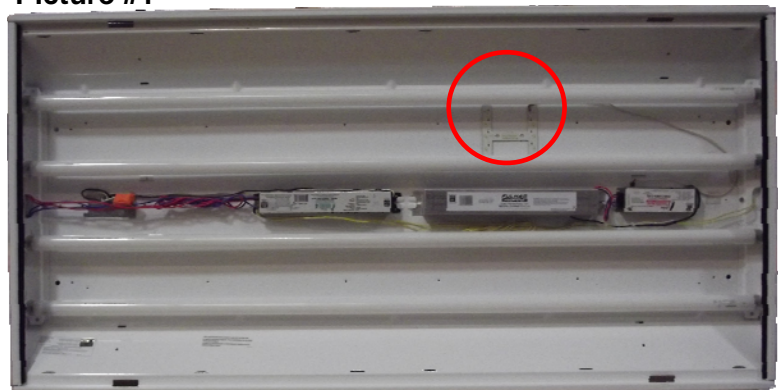

Picture #2

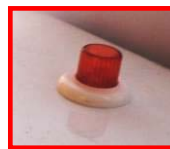

Picture #3

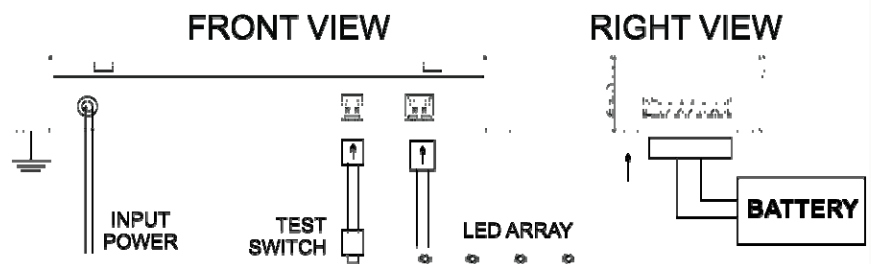

Illustration #2

Note:
If additional wire is needed to complete installation; only wire with a minimum rating of 300V should be used.

4.1 HOTSPOT LED KIT INSTALLATION

7. Wire all LED components based on the Wiring Diagram #1.
8. Test the setup by connecting the LED Battery Pack connector to Emergency LED Driver side Terminal. See picture #4.
9. Re-attach the wire-way cover and the original lamps. See picture #5.
10. Depending on the LED setup and preference, completed installation should look like the following (see pages 7-11).

Note:

If additional wire is needed to complete installation; only wire with a minimum rating of 300V should be used.

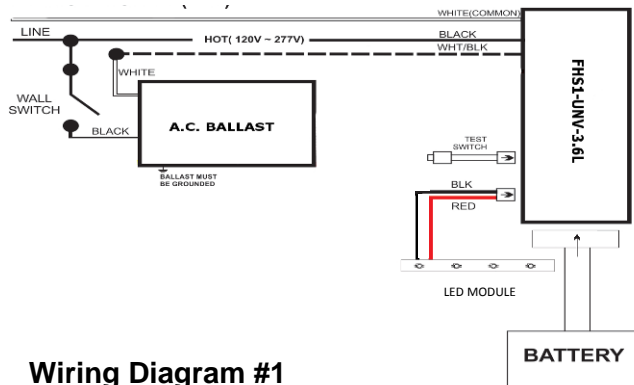

Wiring Diagram #1



Picture #4



Picture #5

5.0 HOTSPOT LED KIT SETUP

2X2 Troffer
Battery: FHSBATT3-C3
LED Array: FHS1-AR-4W-L

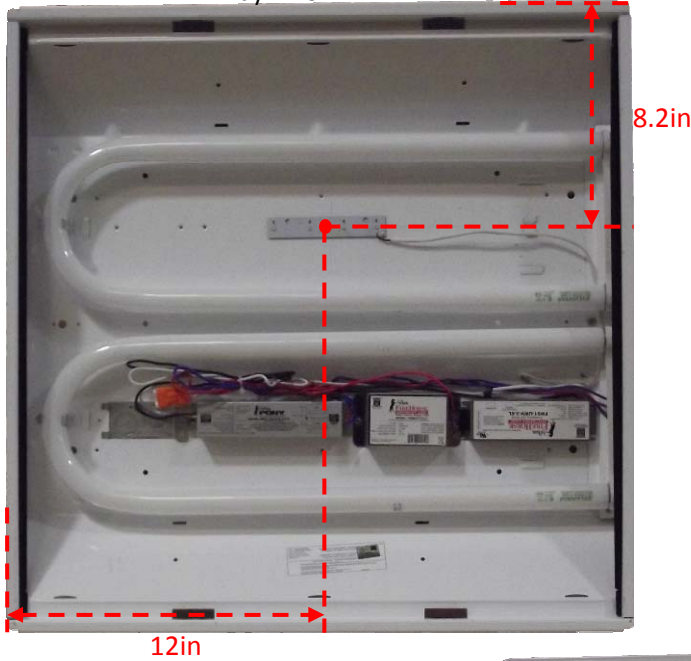

2X2 Troffer
Battery: FHSBATT3-C3
LED Array: FHS3-AR-6W-SH

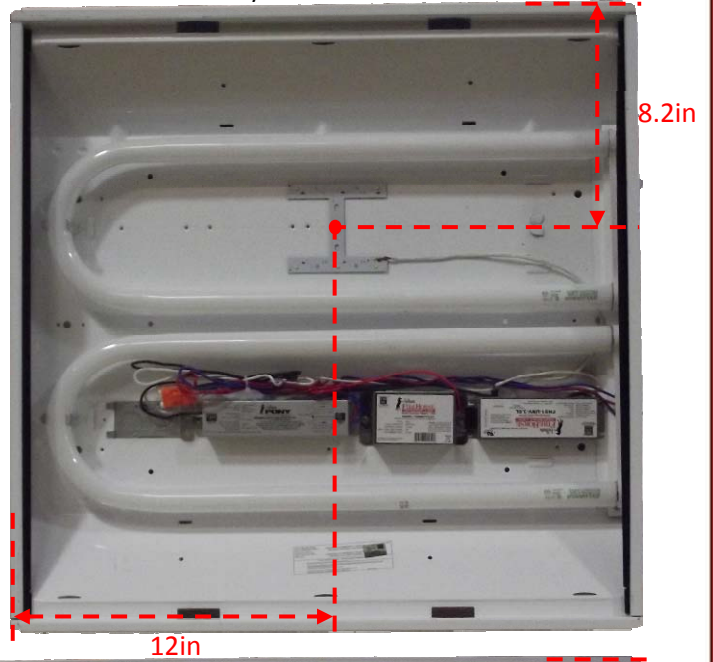

2X4 Troffer
Battery: FHSBATT3-C3
LED Array: FHS3-AR-6W-SH

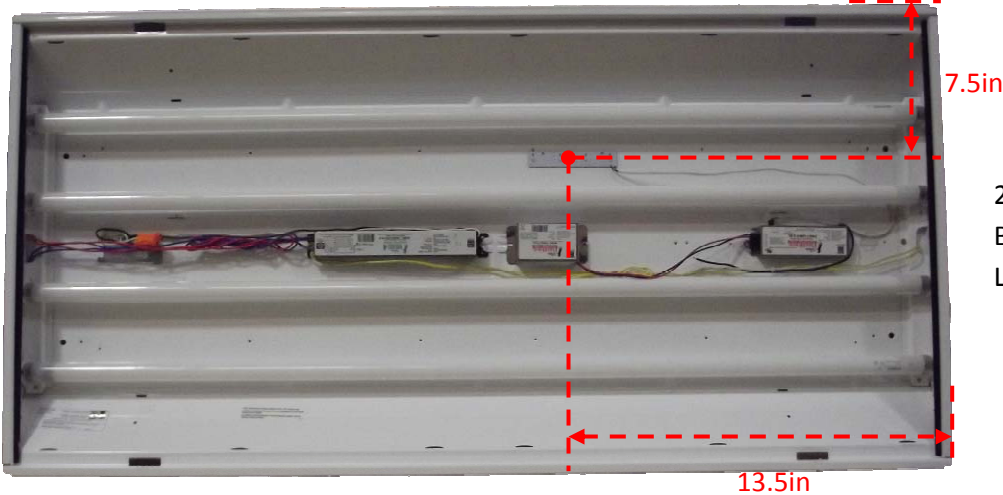
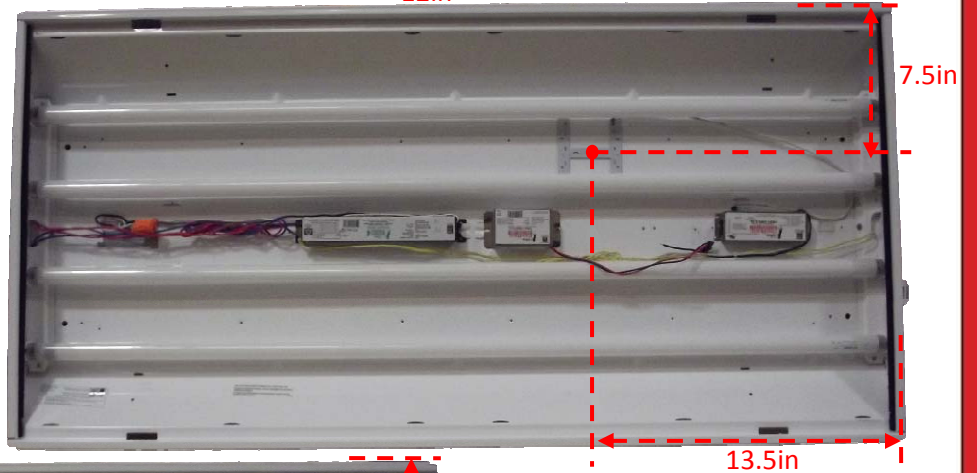

2X4 Troffer
Battery: FHSBATT3-C3
LED Array: FHS1-AR-4W-L

5.1 HOTSPOT LED KIT SETUP

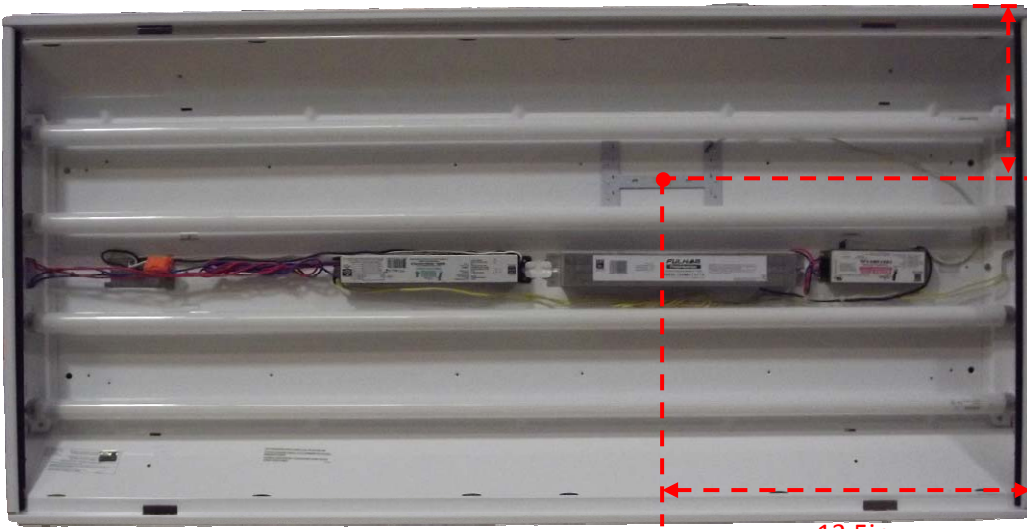

7.5in

2X4 Troffer
Battery: FHSBATT3-F7L
LED Arrays: FHS4-AR-8W-LH,
FHS4-AR-10W-LH

13.5in

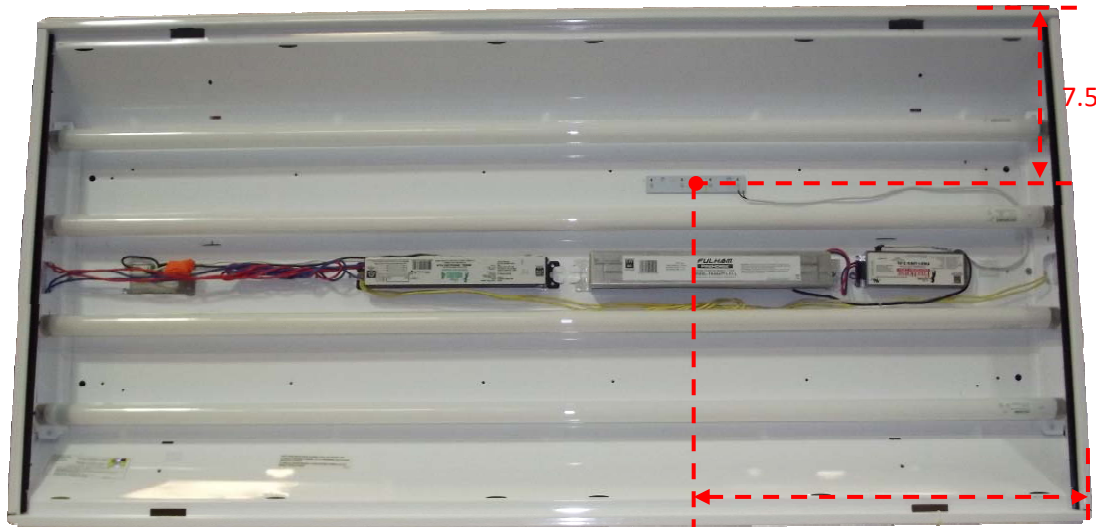

7.5in

2X4 Troffer
Battery: FHSBATT3-F7L
LED Arrays: FHS1-AR-4W-L

13.5in

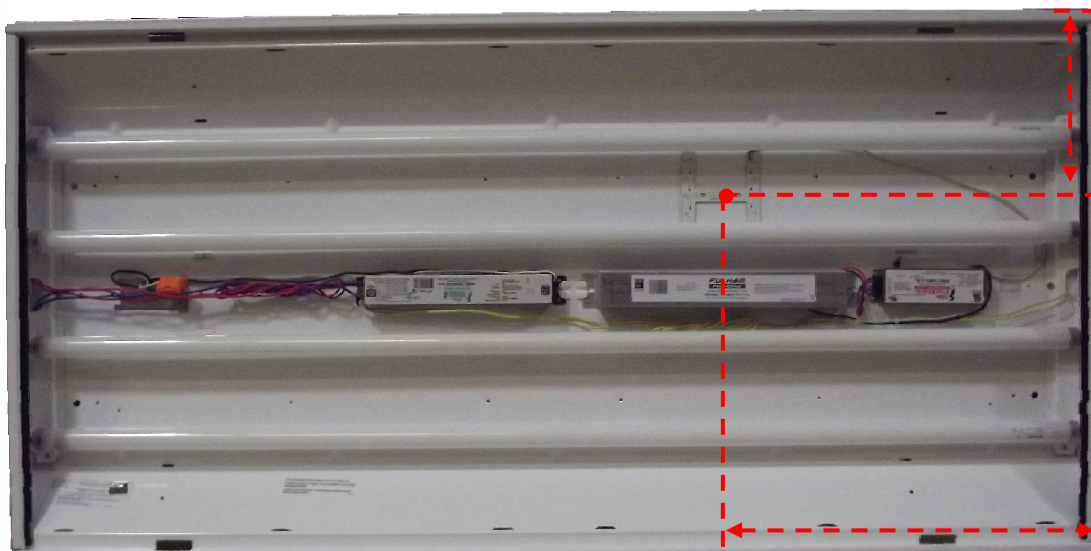

7.5in

2X4 Troffer
Battery: FHSBATT3-F7L
LED Arrays: FHS3-AR-6W-SH,
FHS4-AR-10W-SH

13.5in

5.2 HOTSPOT LED KIT SETUP



2X4 Troffer
Battery: FHSBATT3-F7L
LED Arrays: FHS6-AR-3W-L x1

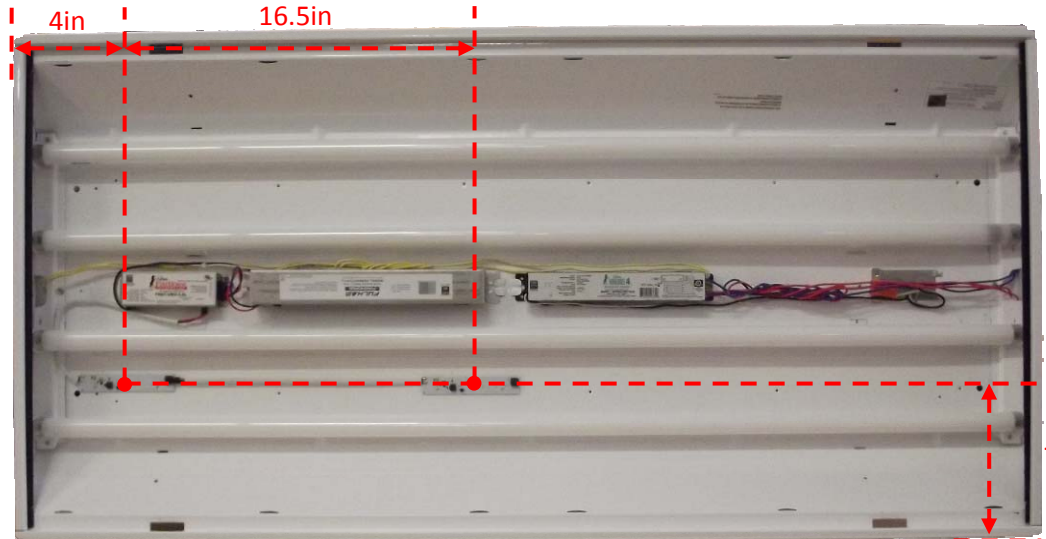

2X4 Troffer
Battery: FHSBATT3-F7L
LED Arrays: FHS6-AR-3W-L x2

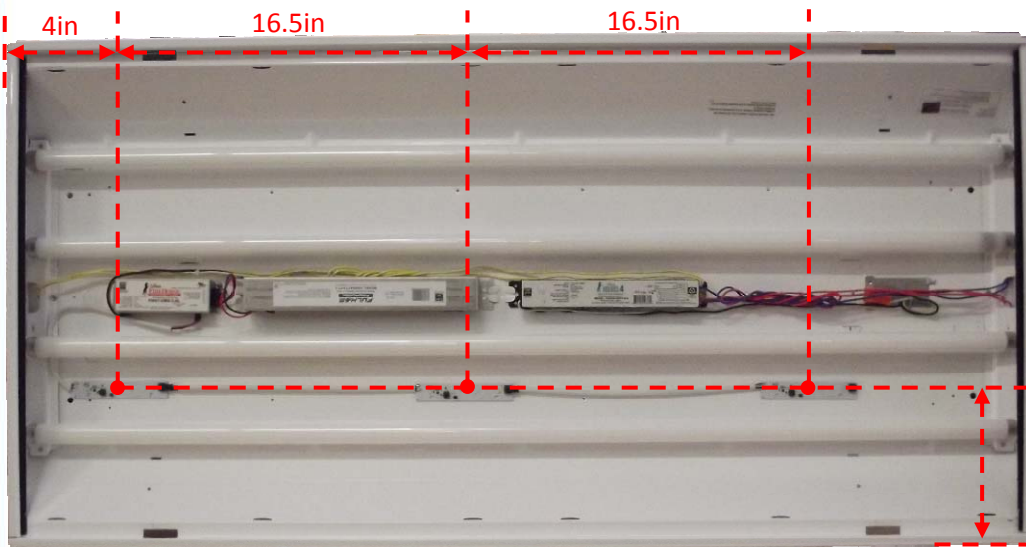

2X4 Troffer
Battery: FHSBATT3-F7L
LED Arrays: FHS6-AR-3W-L x3

5.3 HOTSPOT LED KIT SETUP

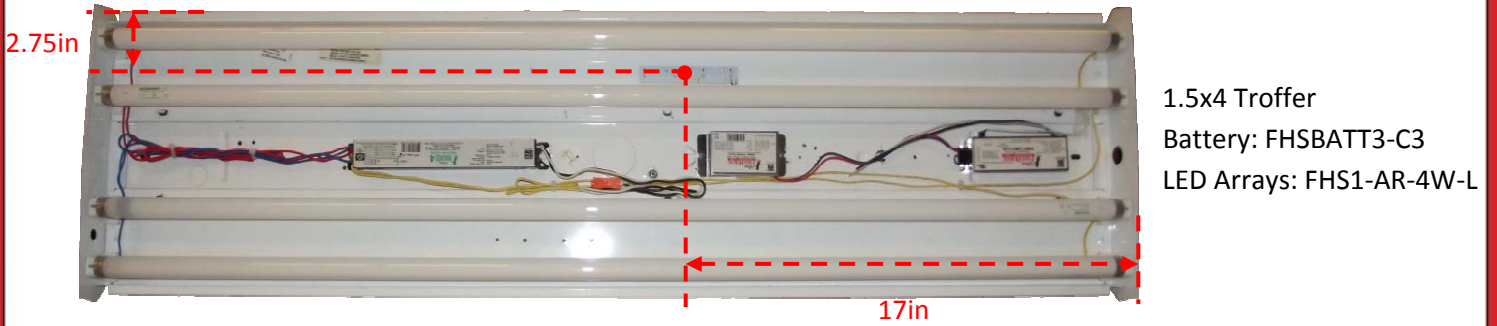

5.4 HOTSPOT LED KIT SETUP

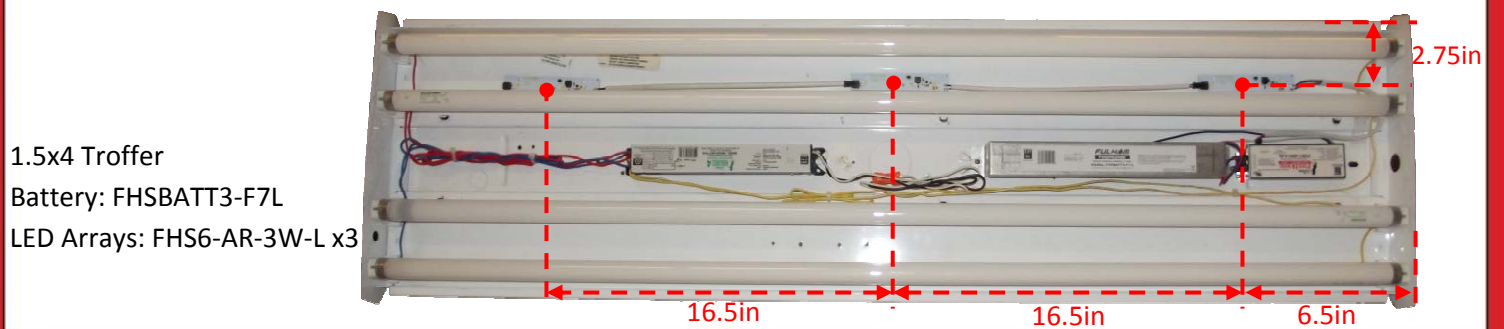
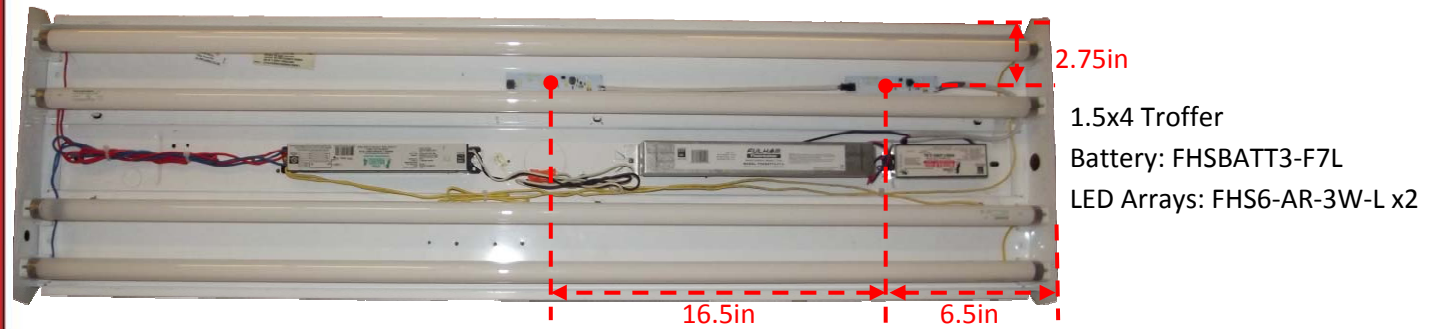
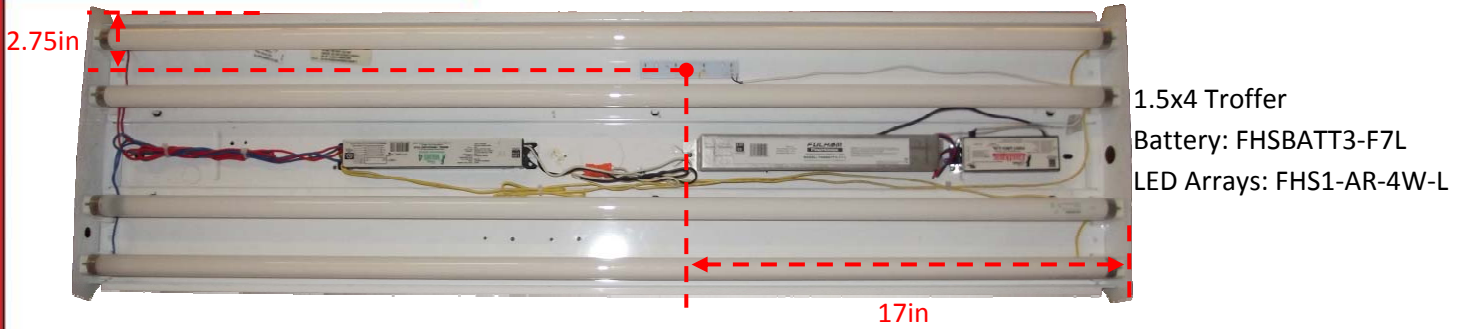

5.5 HOTSPOT LED KIT SETUP



Example of 2X4 Troffer with completed installation and wire way reattached

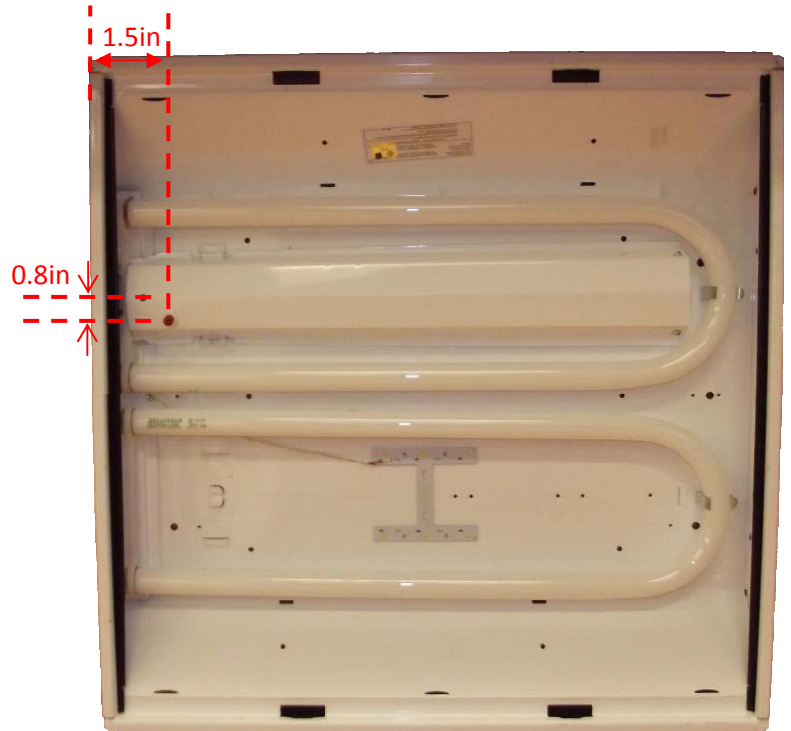

Example of 2X2 Troffer with completed installation and wire way reattached

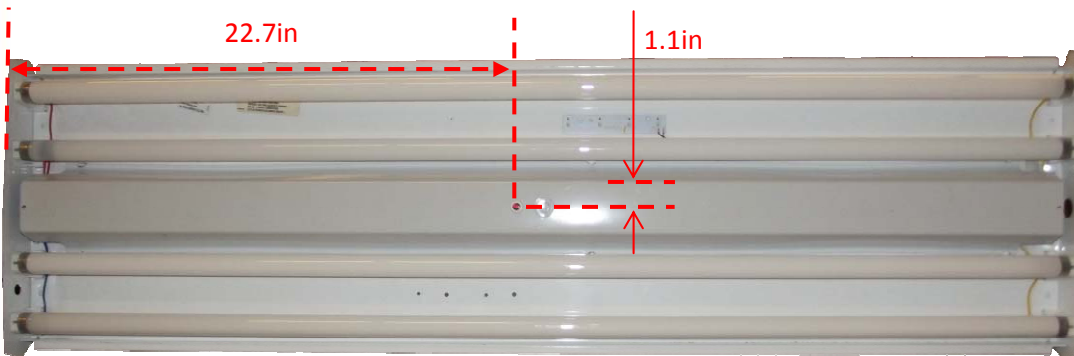

Example of 1.5X4 Troffer with completed installation and wire way reattached



LED EMERGENCY LIGHTING SYSTEM

MANUAL FOR HOTSPOT LED KIT INSTALLATION

6.0 WARRANTY

Warranty

Please see our warranty policy on Fulham's LED Emergency Lighting Program.

Component Part Numbers

To order Hotspot LED Modules, Drivers, Battery Packs, and/or Hotspot LED kits, please contact us and use the part numbers below to order:

Hotspot LED Module: FHS1-AR-4W-L, FHS3-AR-6W-SH, FHS3-AR-10W-SH, FHS4-AR-8W-LH, FHS4-AR-10W-LH, or FHS6-AR-3W-L

Hotspot LED Driver: FHS1-UNV-3.6L

Hotspot LED Battery Pack: FHSBATT3-C3, FHSBATT3-D4, or FHSBATT3-F7L

Hotspot LED Retrofit Kit Part Number: FHSKIT-TXXLNXX or FHSKIT-TXXXHXX