

# 4SHP14LB

## PRODUCT SPECIFICATIONS

14 SEER SPLIT SYSTEM  
HEAT PUMP

FORM NO. 4SHP14LB-100 (10/2015)



### COMPRESSOR

- High-efficiency scroll compressor
- R410a refrigerant
- Grommet-mounted compressor for quiet operation
- Protected against high temperature motor overload conditions

### CABINET

- Full metal louvered panel coil guard protection that is easily removed for coil cleaning
- Controls located in corner for easy installation and service
- Rounded corners for safety and attractive, clean appearance
- Baked polyester paint finish over galvanized steel for maximum durability
- PVC-coated wire fan discharge grille
- External gauge ports for easy service
- Raised base pan with ports allows for excellent water and debris drainage

### COMPONENTS

- Filter drier shipped loose for installation flexibility
- Discharge muffler for quiet operation
- High Pressure switch
- Low pressure switch for loss of charge system protection
- Reliable, solid state, time-initiated, temperature terminated defrost system
- Service valves positioned for quick installation and easy service
- Trade-available components
- Defrost control features built-in diagnostics for easier service
- Defrost control has short cycle protection to protect compressor
- Defrost control is Quiet Shift™ capable
- Defrost cycle is field selectable 30/60/90 minutes

### DESIGN

- Designed for ambients up to 125°F

### COIL

- Enhanced aluminum fins and copper tubing for high efficiency and capacity
- Raised coil prevents debris from collecting in bottom of coil and causing loss of airflow

### ACCESSORIES

- Low ambient control kit
- Crank case heater
- TXV kit
- Hard start kit
- Fossil fuel kit
- Sound cover

### WARRANTY

- 10 year limited warranty on compressor
- 5 year limited warranty on all parts
- Extended warranty available

*\*Warranty provides for a total of 10 years of limited warranty coverage (Standard 5-year limited parts warranty plus an additional 5-year limited extended parts warranty). Warranty must be registered online within 60 days of installation to qualify for 10-year coverage. Unregistered equipment defaults to 5-year coverage.*



**MODEL NUMBER GUIDE**

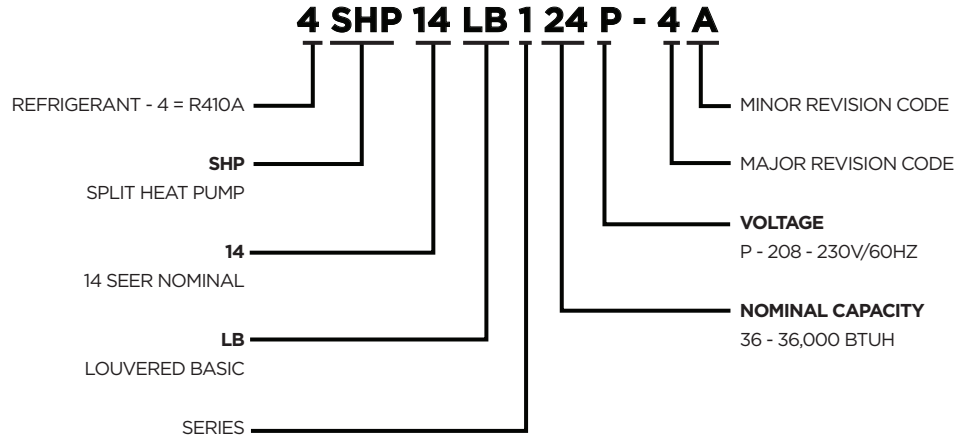

**PHYSICAL AND ELECTRICAL**

Model	Voltage/ Phase/ Hz	Voltage Range	Min. Circuit Amp.	Max. Over current Device (amps)	Compressor		Fan Motor			Refrig. Charge+ (oz.)	Rating (dBA)
					Rated Load (amps)	Locked Rotor (amps)	Rated Load (amps)	Rated HP	Nom. RPM		
4SHP14LB118P-7	208-230/60/1	197-253	12.2	20	9.0	48	1.0	1/6	825	93	76
4SHP14LB124P-7	208-230/60/1	197-253	17.9	30	13.5	58	1.1	1/6	825	94	76
4SHP14LB130P-7	208-230/60/1	197-253	17.1	25	12.8	64	1.1	1/6	825	90	76
4SHP14LB136P-7	208-230/60/1	197-253	18.7	30	14.1	77	1.1	1/6	825	150	76
4SHP14LB142P-7	208-230/60/1	197-253	24.2	40	18.0	112	1.8	1/3	825	184	79
4SHP14LB148P-7	208-230/60/1	197-253	29.0	50	21.8	117	1.8	1/3	825	161	80
4SHP14LB160P-7	208-230/60/1	197-253	29.4	50	22.1	125	1.8	1/3	825	197	80

Note: Weights listed are unit weights with packaging.  
+ Factory charged for 15 feet of line set. Adjust per installation instructions.

**UNIT DIMENSIONS AND SOUND RATINGS**

Model No.	Dimensions (inch)			Shipping Weight (lbs.)
	A-Width	B-Depth	C-Height	
4SHP14LB118P-7	29.25	31.25	37.75	175
4SHP14LB124P-7	29.25	31.25	37.75	177
4SHP14LB130P-7	29.25	31.25	37.75	178
4SHP14LB136P-7	29.25	31.25	33.75	202
4SHP14LB142P-7	35.75	37.75	37.75	272
4SHP14LB148P-7	35.75	37.75	37.75	273
4SHP14LB160P-7	35.75	37.75	43.75	297

Note: Dimensions listed are unit sizes w/o packaging

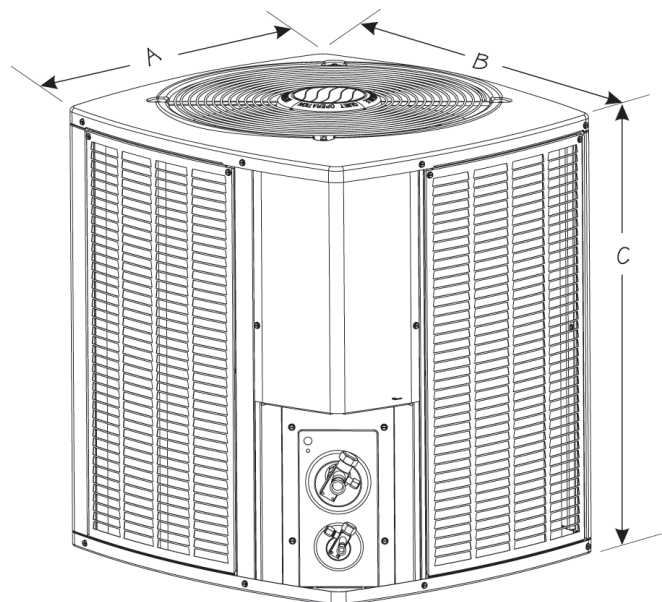

**COOLING PERFORMANCE WITH EVAPORATOR COILS**

Outdoor Model	Indoor Model	Cooling				Heating				CFM	Refrigerant Connection				Refrig. Line Size		Indoor Expansion Device			
	Evap. Coil <sup>3</sup>	SEER	EER	AHRI Rated Capacity <sup>1</sup> BTUH	Sensible Capacity BTUH	HSPF	47°		17°		Outdoor		Indoor		Suction	Liquid	Piston <sup>2</sup>	TXV		
							Btuh	COP	Btuh		COP	Suction	Liquid	Suction					Liquid	
4SHP14L*118P-7	E*1P23A+H4TXV01	14.0	12.0	18,000	13,200	8.2	17,000	3.50	10,000	2.30	650	3/4	3/8	3/4	3/8	3/4	3/8	N/A	H4TXV01	
4SHP14L*124P-7	E*1P24(A,B)+H4TXV01+TDR	14.0	11.5	23,400	17,000	8.2	21,600	3.40	14,000	2.30	850	3/4	3/8	3/4	3/8	3/4	3/8		H4TXV01	
	E*1P29(A,B)+H4TXV01+TDR	14.0	11.5	23,400	17,000	8.2	21,600	3.40	14,000	2.30	850	3/4	3/8	3/4	3/8	3/4	3/8			
4SHP14L*130P-7	E*1P43(B,C)+H4TXV02+TDR	14.0	11.5	28,000	20,300	8.2	25,000		15,000		1050	3/4	3/8	3/4	3/8	3/4	3/8		N/A	H4TXV02
4SHP14L*136P-7	E*1P43B+H4TXV02	14.0	12.0	34,000	25,100	8.2	33800	3.50	21,800	2.50	1250	7/8	3/8	3/4	3/8	7/8	3/8			
	E*1P49C+H4TXV02	14.0	12.0	34,000	25,100	8.2	33800	3.50	21,800	2.50	1250	7/8	3/8	7/8	3/8	7/8	3/8			
4SHP14L*142P-7	E*1P49C+H4TXV02+TDR	14.0	12.0	41000	30,200	8.2	40000	3.50	27,800	2.40	1400	7/8	3/8	7/8	3/8	7/8	3/8			
	E*1P62D+H4TXV02+TDR	14.0	12.0	41000	30,200	8.2	40000	3.50	28,800	2.40	1400	7/8	3/8	7/8	3/8	7/8	3/8			
4SHP14L*148P-7	E*1P49C+H4TXV02+TDR	14.0	12.0	47000	34,600	8.2	46000	3.40	29,600	2.50	1600	7/8	3/8	7/8	3/8	7/8	3/8			
	E*1P62D+H4TXV02+TDR	14.0	12.0	47000	34,600	8.2	46000	3.40	29,600	2.50	1600	7/8	3/8	7/8	3/8	7/8	3/8			
4SHP14L*160P-7	E*1P62C+H4TXV03+TDR	14.0	12.0	57000	42,100	8.2	55000	3.40	36,000	2.50	1900	7/8	3/8	7/8	3/8	1 1/8	3/8			
	E*1P62D+H4TXV03+TDR	14.0	12.0	57000	42,100	8.2	55000	3.40	36,000	2.50	1900	7/8	3/8	7/8	3/8	1 1/8	3/8	H4TXV03		

Note:  
 Certified in accordance with Unitary Air Conditioner Certification Program, which is based on AHRI Standard 210/240 Required to achieve AHRI rating. If NA (Not Applicable) is in the piston column, then TXV is required.  
 A blower time delay relay is required to achieve AHRI rating. This feature is standard on all Allied Air Enterprises furnace and AH products.

**COOLING PERFORMANCE WITH AIR HANDLERS AND FURNACES**

Outdoor Model	Indoor Model	Furnace	Cooling				Heating				CFM	
	Evap. Coil <sup>3</sup>		SEER	EER	AHRI Rated Capacity <sup>1</sup> BTUH	Sensible Capacity BTUH	HSPF	47°		17°		
								Btuh	COP	Btuh		COP
4SHP14L*118P-7	BC*3M18C****P+TXV		14.00	12.00	18,000	13,200	8.20	17,000	3.50	10,000	2.30	650
	BC*3M24E****P+TXV		15.10	12.50	18,000	13,200	8.20	17,000	3.50	10,000	2.30	650
	BCS2M24S****P+TXV		16.00	13.00	18,000	13,200	8.20	17,000	3.50	10,000	2.30	650
	BCS2M24V00NA1P+H4TXV01		16.00	13.00	18,000	13,200	8.20	17,000	3.50	10,000	2.30	650
	E*1P23A+H4TXV01	A80DF1E045A12	15.10	12.50	18,000	13,200	8.20	17,000	3.50	10,000	2.30	650
	E*1P23A+H4TXV01	A80UH1E045A12	16.00	13.00	18,000	13,200	8.20	17,000	3.50	10,000	2.30	650
	E*1P23A+H4TXV01	A80US2V070A12	16.00	13.00	18,000	13,200	8.20	17,000	3.50	10,000	2.30	650
	E*1P23B+H4TXV01	A80DF1E070B12	15.10	12.50	18,000	13,200	8.20	17,000	3.50	10,000	2.30	650
	E*1P23B+H4TXV01	A80UH1E070B12	15.10	12.50	18,000	13,200	8.20	17,000	3.50	10,000	2.30	650
	E*1P23B+H4TXV01	A80US2V090B16	16.00	13.00	18,000	13,200	8.20	17,000	3.50	10,000	2.30	650
	E*1P23B+H4TXV01	A80DF2V070A12	16.00	13.00	18,000	13,200	8.20	17,000	3.50	10,000	2.30	650
	E*1P23B+H4TXV01	A80DS2V070A12	16.00	13.00	18,000	13,200	8.20	17,000	3.50	10,000	2.30	650
	E*1P23B+H4TXV01	A80US2V070A12	16.00	13.00	18,000	13,200	8.20	17,000	3.50	10,000	2.30	650
	E*1P23B+H4TXV01	A80UH2V090B16	16.00	13.00	18,000	13,200	8.20	17,000	3.50	10,000	2.30	650
	E*1P23B+H4TXV01	A80US2V090B12	16.00	13.00	18,000	13,200	8.20	17,000	3.50	10,000	2.30	650
	E*1P23B+H4TXV01	A95DF1E045B12	15.10	12.50	18,000	13,200	8.20	17,000	3.50	10,000	2.30	650
	E*1P23B+H4TXV01	A96DS2V045B12	15.10	12.50	18,000	13,200	8.20	17,000	3.50	10,000	2.30	650
	E*1P23B+H4TXV01	A96DS2V070B16	15.10	12.50	18,000	13,200	8.20	17,000	3.50	10,000	2.30	650
	E*1P23B+H4TXV01	A95UH1E045B12	15.10	12.50	18,000	13,200	8.20	17,000	3.50	10,000	2.30	650
	E*1P23B+H4TXV01	A95UH1E070B12	15.10	12.50	18,000	13,200	8.20	17,000	3.50	10,000	2.30	650
	E*1P23B+H4TXV01	A95DF2E045B12	15.10	12.50	18,000	13,200	8.20	17,000	3.50	10,000	2.30	650
	E*1P23B+H4TXV01	A95DF2E070B16	15.10	12.50	18,000	13,200	8.20	17,000	3.50	10,000	2.30	650
	E*1P23B+H4TXV01	A95UH2E045B12	15.10	12.50	18,000	13,200	8.20	17,000	3.50	10,000	2.30	650
	E*1P23B+H4TXV01	A95UH2E070B12	15.10	12.50	18,000	13,200	8.20	17,000	3.50	10,000	2.30	650
	E*1P23B+H4TXV01	A96US2V045B12	15.10	12.50	18,000	13,200	8.20	17,000	3.50	10,000	2.30	650
	E*1P23B+H4TXV01	A96US2V070B12	16.00	13.00	18,000	13,200	8.20	17,000	3.50	10,000	2.30	650
	E*1P23B+H4TXV01	A97DSMV070B12	16.00	13.00	18,000	13,200	8.20	17,000	3.50	10,000	2.30	650
	E*1P23B+H4TXV01	A97USMV070B12	16.00	13.00	18,000	13,200	8.20	17,000	3.50	10,000	2.30	650
	E*1P23B+H4TXV01	EFV08BC	16.00	13.00	18,000	13,200	8.20	17,000	3.50	10,000	2.30	650
	E*1P24A+H4TXV01	A80DF1E045A12	15.10	12.50	18,000	13,200	8.20	17,000	3.50	10,000	2.30	650
	E*1P24A+H4TXV01	A80UH1E045A12	15.10	12.50	18,000	13,200	8.20	17,000	3.50	10,000	2.30	650
	E*1P24A+H4TXV01	A80US2V070A12	16.00	13.00	18,000	13,200	8.20	17,000	3.50	10,000	2.30	650
	E*1P24B+H4TXV01	A80DF1E070B12	15.10	12.50	18,000	13,200	8.20	17,000	3.50	10,000	2.30	650
	E*1P24B+H4TXV01	A80UH1E070B12	15.10	12.50	18,000	13,200	8.20	17,000	3.50	10,000	2.30	650
	E*1P24B+H4TXV01	A80US2V090B16	15.10	12.50	18,000	13,200	8.20	17,000	3.50	10,000	2.30	650
	E*1P24B+H4TXV01	A80DF2V070A12	16.00	13.00	18,000	13,200	8.20	17,000	3.50	10,000	2.30	650
	E*1P24B+H4TXV01	A80DS2V070A12	16.00	13.00	18,000	13,200	8.20	17,000	3.50	10,000	2.30	650
	E*1P24B+H4TXV01	A80US2V070A12	16.00	13.00	18,000	13,200	8.20	17,000	3.50	10,000	2.30	650
	E*1P24B+H4TXV01	A80UH2V090B16	16.00	13.00	18,000	13,200	8.20	17,000	3.50	10,000	2.30	650
	E*1P24B+H4TXV01	A80US2V090B12	16.00	13.00	18,000	13,200	8.20	17,000	3.50	10,000	2.30	650
E*1P24B+H4TXV01	A95DF1E045B12	15.10	12.50	18,000	13,200	8.20	17,000	3.50	10,000	2.30	650	
E*1P24B+H4TXV01	A95UH1E045B12	15.10	12.50	18,000	13,200	8.20	17,000	3.50	10,000	2.30	650	
E*1P24B+H4TXV01	A95UH1E070B12	15.10	12.50	18,000	13,200	8.20	17,000	3.50	10,000	2.30	650	
E*1P24B+H4TXV01	A96US2V045B12	15.10	12.50	18,000	13,200	8.20	17,000	3.50	10,000	2.30	650	

Note:

1. Certified in accordance with Unitary Air Conditioner Certification Program, which is based on AHRI Standard 210/240
2. Required to achieve AHRI rating. If NA (Not Applicable) is in the piston column, then TXV is required.
3. A blower time delay relay is required to achieve AHRI rating. This feature is standard on all Allied Air Enterprises furnace and AH products.

**COOLING PERFORMANCE WITH AIR HANDLERS AND FURNACES**

Outdoor Model	Indoor Model	Furnace	Cooling				Heating				CFM	
	Evap. Coil <sup>3</sup>		SEER	EER	AHRI Rated Capacity <sup>1</sup> BTUH	Sensible Capacity BTUH	HSPF	47°		17°		
								Btuh	COP	Btuh		COP
<b>4SHP14L*118P-7</b>	E*1P24B+H4TXV01	A96US2V070B12	15.10	12.50	18,000	13,200	8.20	17,000	3.50	10,000	2.30	650
	E*1P24B+H4TXV01	A97DSMV070B12	16.00	13.00	18,000	13,200	8.20	17,000	3.50	10,000	2.30	650
	E*1P24B+H4TXV01	A97USMV070B12	16.00	13.00	18,000	13,200	8.20	17,000	3.50	10,000	2.30	650
	E*1P24B+H4TXV01	EFV08BC	15.10	12.50	18,000	13,200	8.20	17,000	3.50	10,000	2.30	650
<b>4SHP14L*124P-7</b>	BCE3M24C****P+H4TXV01		14.00	12.00	23400	17,100	8.20	21600	3.4	14000	2.30	850
	BCE3M30E****X		15.00	12.50	23400	17,100	8.50	21600	3.4	14000	2.30	850
	BCS2M24S00NA1P+H4TXV01		15.00	12.50	23400	17,100	8.50	21600	3.4	13600	2.30	850
	BCS2M24V00NA1P+H4TXV01		15.00	12.50	23400	17,100	8.50	21600	3.4	13600	2.30	850
	BCS2M36V00NA1P+H4TXV01		15.00	12.50	23400	17,100	8.20	21600	3.4	13600	2.30	850
	E*1P23A+H4TXV01	A80DF2V070A12*	15.00	12.50	23400	17,100	8.20	21600	3.6	14000	2.50	850
	E*1P23A+H4TXV01	A80UH1E045A12*	14.50	12.00	23400	17,100	8.20	21600	3.6	14000	2.50	875
	E*1P23A+H4TXV01	A80UH2V070A12*	15.00	12.50	23400	17,100	8.20	21600	3.6	14000	2.50	850
	E*1P23A+H4TXV01	A80DS2V070A12*	15.00	12.50	23400	17,100	8.20	21600	3.6	14000	2.50	850
	E*1P23A+H4TXV01	A80DF1E045A12	15.00	12.50	23400	17,100	8.20	21600	3.6	14000	2.50	850
	E*1P23A+H4TXV01	A80US2V070A12*	15.00	12.50	23400	17,100	8.20	21600	3.6	14000	2.50	850
	E*1P23B+H4TXV01	A80US2V090B16*	15.00	12.50	23400	17,100	8.20	21600	3.6	14000	2.50	850
	E*1P23B+H4TXV01	A80UH1E070B12*	15.00	12.50	23400	17,100	8.20	21600	3.6	14000	2.50	850
	E*1P23B+H4TXV01	A95UH1E045B12S	14.50	12.00	23400	17,100	8.20	21600	3.6	14000	2.50	875
	E*1P23B+H4TXV01	A97DSMV070B12*	15.00	12.50	23400	17,100	8.20	21600	3.6	14000	2.50	850
	E*1P23B+H4TXV01	A95DF2V070B16S	15.00	12.50	23400	17,100	8.20	21600	3.6	14000	2.50	850
	E*1P23B+H4TXV01	A80US2V090B12*	15.00	12.50	23400	17,100	8.20	21600	3.6	14000	2.50	850
	E*1P23B+H4TXV01	A95DF1E045B12S	14.50	12.00	23400	17,100	8.20	21600	3.6	14000	2.50	875
	E*1P23B+H4TXV01	A97USMV070B12*	15.00	12.50	23400	17,100	8.20	21600	3.6	14000	2.50	850
	E*1P23B+H4TXV01	A95UH2V070B12S	15.00	12.50	23400	17,100	8.20	21600	3.6	14000	2.50	850
	E*1P23B+H4TXV01	A80UH2V090B16*	15.00	12.50	23400	17,100	8.20	21600	3.6	14000	2.50	850
	E*1P23B+H4TXV01	A95UH2V045B12S	15.00	12.50	23400	17,100	8.20	21600	3.6	14000	2.50	850
	E*1P23B+H4TXV01	EFV08BC	15.00	12.50	23400	17,100	8.20	21600	3.6	14000	2.50	850
	E*1P23B+H4TXV01	A80UH2V090B12*	15.00	12.50	23400	17,100	8.20	21600	3.6	14000	2.50	850
	E*1P23B+H4TXV01	A80DF2V090B16*	15.00	12.50	23400	17,100	8.20	21600	3.6	14000	2.50	850
	E*1P23B+H4TXV01	A80DF1E070B12	15.00	12.50	23400	17,100	8.20	21600	3.6	14000	2.50	850
	E*1P23B+H4TXV01	A95UH1E070B12S	14.50	12.00	23400	17,100	8.20	21600	3.6	14000	2.50	875
	E*1P23B+H4TXV01	A95DF2V045B12S	15.00	12.50	23400	17,100	8.20	21600	3.6	14000	2.50	850
	E*1P23B+H4TXV01	A96DS2V045B12S	15.00	12.50	23400	17,100	8.20	21600	3.6	14000	2.50	850
	E*1P23B+H4TXV01	A96DS2V070B16S	15.00	12.50	23400	17,100	8.20	21600	3.6	14000	2.50	850
	E*1P23B+H4TXV01	A96US2V045B12S	15.00	12.50	23400	17,100	8.20	21600	3.6	14000	2.50	850
	E*1P23B+H4TXV01	A96US2V070B12S	15.00	12.50	23400	17,100	8.20	21600	3.6	14000	2.50	850
	E*1P23B+H4TXV01	A80DS2V090B16*	15.00	12.50	23400	17,100	8.20	21600	3.6	14000	2.50	850
	E*1P24A+H4TXV01	A80DF1E045A12	15.00	12.50	23400	17,100	8.50	21600	3.6	14000	2.50	850
	E*1P24A+H4TXV01	A80DF2V070A12*	15.00	12.50	23400	17,100	8.50	21600	3.6	14000	2.50	850
	E*1P24A+H4TXV01	A80UH2V070A12*	15.00	12.50	23400	17,100	8.50	21600	3.6	14000	2.50	850
E*1P24A+H4TXV01	A80US2V070A12*	15.00	12.50	23400	17,100	8.50	21600	3.6	14000	2.50	850	
E*1P24A+H4TXV01	A80UH1E045A12*	14.50	12.00	23400	17,100	8.50	21600	3.6	14000	2.50	875	

Note:

1. Certified in accordance with Unitary Air Conditioner Certification Program, which is based on AHRI Standard 210/240
2. Required to achieve AHRI rating. If NA (Not Applicable) is in the piston column, then TXV is required.
3. A blower time delay relay is required to achieve AHRI rating. This feature is standard on all Allied Air Enterprises furnace and AH products.

**COOLING PERFORMANCE WITH AIR HANDLERS AND FURNACES**

Outdoor Model	Indoor Model	Furnace	Cooling				Heating				CFM	
	Evap. Coil <sup>3</sup>		SEER	EER	AHRI Rated Capacity <sup>1</sup> BTUH	Sensible Capacity BTUH	HSPF	47°		17°		
								Btuh	COP	Btuh		COP
4SHP14L*124P-7	E*1P24A+H4TXV01	A80DS2V070A12*	15.00	12.50	23400	17,100	8.50	21600	3.6	14000	2.50	850
	E*1P24B+H4TXV01	L83UF1V57/72E12	15.00	12.50	23400	17,100	8.20	21600	3.6	14000	2.50	850
	E*1P24B+H4TXV01	L83HR1V84/95E12	15.00	12.50	23400	17,100	8.20	21600	3.6	14000	2.50	850
	E*1P24B+H4TXV01	A95UH1E070B12S	14.50	12.00	23400	17,100	8.50	21600	3.6	14000	2.50	875
	E*1P24B+H4TXV01	A95UH2V070B12S	15.00	12.50	23400	17,100	8.50	21600	3.6	14000	2.50	850
	E*1P24B+H4TXV01	A95DF1E045B12S	14.50	12.00	23400	17,100	8.50	21600	3.6	14000	2.50	875
	E*1P24B+H4TXV01	A80UH1E070B12*	15.00	12.50	23400	17,100	8.50	21600	3.6	14000	2.50	850
	E*1P24B+H4TXV01	A95UH1E045B12S	14.50	12.00	23400	17,100	8.50	21600	3.6	14000	2.50	875
	E*1P24B+H4TXV01	L83HF1V84/95E12	15.00	12.50	23400	17,100	8.20	21600	3.6	14000	2.50	850
	E*1P24B+H4TXV01	L83B*1V84/95E14	15.00	12.50	23400	17,100	8.20	21600	3.6	14000	2.50	850
	E*1P24B+H4TXV01	A80US2V090B12*	15.00	12.50	23400	17,100	8.50	21600	3.6	14000	2.50	850
	E*1P24B+H4TXV01	A95DF2V045B12S	15.00	12.50	23400	17,100	8.50	21600	3.6	14000	2.50	850
	E*1P24B+H4TXV01	A80DF1E070B12	15.00	12.50	23400	17,100	8.50	21600	3.6	14000	2.50	850
	E*1P24B+H4TXV01	L83UF1V84/95E14	15.00	12.50	23400	17,100	8.20	21600	3.6	14000	2.50	850
	E*1P24B+H4TXV01	A97DSMV070B12*	15.00	12.50	23400	17,100	8.50	21600	3.6	14000	2.50	850
	E*1P24B+H4TXV01	A97USMV070B12*	15.00	12.50	23400	17,100	8.50	21600	3.6	14000	2.50	850
	E*1P24B+H4TXV01	A80UH2V090B16*	15.00	12.50	23400	17,100	8.50	21600	3.6	14000	2.50	850
	E*1P24B+H4TXV01	A80UH2V090B12*	15.00	12.50	23400	17,100	8.50	21600	3.6	14000	2.50	850
	E*1P24B+H4TXV01	EFV08BC	15.00	12.50	23400	17,100	8.50	21600	3.6	14000	2.50	850
	E*1P24B+H4TXV01	A80DF2V090B16*	15.00	12.50	23400	17,100	8.50	21600	3.6	14000	2.50	850
	E*1P24B+H4TXV01	A95UH2V045B12S	15.00	12.50	23400	17,100	8.50	21600	3.6	14000	2.50	850
	E*1P24B+H4TXV01	A95DF2V070B16S	15.00	12.50	23400	17,100	8.50	21600	3.6	14000	2.50	850
	E*1P24B+H4TXV01	A80US2V090B16*	15.00	12.50	23400	17,100	8.50	21600	3.6	14000	2.50	850
	E*1P24B+H4TXV01	A80DS2V090B16*	15.00	12.50	23400	17,100	8.50	21600	3.6	14000	2.50	850
	E*1P24B+H4TXV01	A96DS2V045B12S	15.00	12.50	23400	17,100	8.50	21600	3.6	14000	2.50	850
	E*1P24B+H4TXV01	A96DS2V070B16S	15.00	12.50	23400	17,100	8.50	21600	3.6	14000	2.50	850
	E*1P24B+H4TXV01	A96US2V045B12S	15.00	12.50	23400	17,100	8.50	21600	3.6	14000	2.50	850
	E*1P24B+H4TXV01	A96US2V070B12S	15.00	12.50	23400	17,100	8.50	21600	3.6	14000	2.50	850
	E*1P24B+H4TXV01	L85B*1V67/87E14	15.10	12.50	23400	17,100	8.20	21600	3.6	14000	2.50	850
	E*1P29A+H4TXV01	A80DF1E045A12	15.00	12.50	23400	17,100	8.50	21600	3.6	14000	2.50	850
	E*1P29A+H4TXV01	A80UH2V070A12*	15.00	12.50	23400	17,100	8.50	21600	3.6	14000	2.50	850
	E*1P29A+H4TXV01	A80DF2V070A12*	15.00	12.50	23400	17,100	8.50	21600	3.6	14000	2.50	850
	E*1P29A+H4TXV01	A80US2V070A12*	15.00	12.50	23400	17,100	8.50	21600	3.6	14000	2.50	850
	E*1P29A+H4TXV01	A80UH1E045A12*	14.50	12.00	23400	17,100	8.50	21600	3.6	14000	2.50	850
	E*1P29A+H4TXV01	A80DS2V070A12*	15.00	12.50	23400	17,100	8.50	21600	3.6	14000	2.50	850
	E*1P29B+H4TXV01	A97USMV070B12*	15.00	12.50	23400	17,100	8.50	21600	3.6	14000	2.50	850
	E*1P29B+H4TXV01	A80US2V090B12*	15.00	12.50	23400	17,100	8.50	21600	3.6	14000	2.50	850
	E*1P29B+H4TXV01	A95DF2V070B16S	15.00	12.50	23400	17,100	8.50	21600	3.6	14000	2.50	850
	E*1P29B+H4TXV01	A95UH1E045B12S	14.50	12.00	23400	17,100	8.50	21600	3.6	14000	2.50	875
	E*1P29B+H4TXV01	A95DF1E045B12S	14.50	12.00	23400	17,100	8.50	21600	3.6	14000	2.50	875
E*1P29B+H4TXV01	A80DF1E070B12	15.00	12.50	23400	17,100	8.50	21600	3.6	14000	2.50	850	
E*1P29B+H4TXV01	A95UH2V045B12S	15.00	12.50	23400	17,100	8.50	21600	3.6	14000	2.50	850	
E*1P29B+H4TXV01	A97DSMV070B12*	15.00	12.50	23400	17,100	8.50	21600	3.6	14000	2.50	850	
E*1P29B+H4TXV01	A80UH1E070B12*	15.00	12.50	23400	17,100	8.50	21600	3.6	14000	2.50	850	

Note:

1. Certified in accordance with Unitary Air Conditioner Certification Program, which is based on AHRI Standard 210/240
2. Required to achieve AHRI rating. If NA (Not Applicable) is in the piston column, then TXV is required.
3. A blower time delay relay is required to achieve AHRI rating. This feature is standard on all Allied Air Enterprises furnace and AH products.

**COOLING PERFORMANCE WITH AIR HANDLERS AND FURNACES**

Outdoor Model	Indoor Model	Furnace	Cooling				Heating				CFM	
	Evap. Coil <sup>3</sup>		SEER	EER	AHRI Rated Capacity <sup>1</sup> BTUH	Sensible Capacity BTUH	HSPF	47°		17°		
								Btuh	COP	Btuh		COP
4SHP14L*124P-7	E*1P29B+H4TXV01	L83HF1V84/95E12	15.00	12.50	23400	17,100	8.20	21600	3.6	14000	2.50	850
	E*1P29B+H4TXV01	L83UF1V84/95E14	15.00	12.50	23400	17,100	8.20	21600	3.6	14000	2.50	850
	E*1P29B+H4TXV01	A80US2V090B16*	15.00	12.50	23400	17,100	8.50	21600	3.6	14000	2.50	850
	E*1P29B+H4TXV01	L83B*1V84/95E14	15.00	12.50	23400	17,100	8.20	21600	3.6	14000	2.50	850
	E*1P29B+H4TXV01	L83HR1V84/95E12	15.00	12.50	23400	17,100	8.20	21600	3.6	14000	2.50	850
	E*1P29B+H4TXV01	L83UF1V57/72E12	15.00	12.50	23400	17,100	8.20	21600	3.6	14000	2.50	850
	E*1P29B+H4TXV01	A80DF2V090B16*	15.00	12.50	23400	17,100	8.50	21600	3.6	14000	2.50	850
	E*1P29B+H4TXV01	EFV08BC	15.00	12.50	23400	17,100	8.50	21600	3.6	14000	2.50	850
	E*1P29B+H4TXV01	A80UH2V090B12*	15.00	12.50	23400	17,100	8.50	21600	3.6	14000	2.50	850
	E*1P29B+H4TXV01	A80UH2V090B16*	15.00	12.50	23400	17,100	8.50	21600	3.6	14000	2.50	850
	E*1P29B+H4TXV01	A95DF2V045B12S	15.00	12.50	23400	17,100	8.50	21600	3.6	14000	2.50	850
	E*1P29B+H4TXV01	A95UH2V070B12S	15.00	12.50	23400	17,100	8.50	21600	3.6	14000	2.50	850
	E*1P29B+H4TXV01	A95UH1E070B12S	14.50	12.00	23400	17,100	8.50	21600	3.6	14000	2.50	875
	E*1P29B+H4TXV01	L85UF1V67/87E14	15.10	12.50	23400	17,100	8.20	21600	3.6	14000	2.50	850
	E*1P29B+H4TXV01	A96DS2V045B12S	15.00	12.50	23400	17,100	8.50	21600	3.6	14000	2.50	850
	E*1P29B+H4TXV01	A96DS2V070B16S	15.00	12.50	23400	17,100	8.50	21600	3.6	14000	2.50	850
	E*1P29B+H4TXV01	A96US2V045B12S	15.00	12.50	23400	17,100	8.50	21600	3.6	14000	2.50	850
	E*1P29B+H4TXV01	A96US2V070B12S	15.00	12.50	23400	17,100	8.50	21600	3.6	14000	2.50	850
E*1P29B+H4TXV01	A80DS2V090B16*	15.00	12.50	23400	17,100	8.50	21600	3.6	14000	2.50	850	
4SHP14L*130P-7	BCE3M30C****P+H4TXV01		14.00	12.00	28600	21,500	8.20	26200	3.4	17,000	2.50	1050
	BCS3M30C****P+H4TXV01		14.00	12.00	28600	21,500	8.20	26200	3.4	17,000	2.50	1050
	BCE3M30E****X		15.00	12.50	28600	21,500	8.50	26200	3.6	17,000	2.50	1050
	BCS2M36S00NA1P+H4TXV01		15.00	12.50	29000	21,500	8.50	26200	3.6	17,000	2.50	1050
	BCS2M36V00NA1P+H4TXV01		15.00	12.50	29000	21,500	8.50	26200	3.6	17,000	2.50	1050
	E*1P24B+H4TXV01	L85B*1V67/87E14	14.00	12.00	28600	21,500	8.20	26000	3.6	17,000	2.50	1050
	E*1P29A+H4TXV01	A80DS2V070A12*	15.00	12.50	29000	21,500	8.50	26200	3.6	17,000	2.50	1050
	E*1P29A+H4TXV01	A80UH1E045A12*	14.00	12.00	29000	21,500	8.20	26200	3.6	17,000	2.50	1050
	E*1P29A+H4TXV01	A80US2V070A12*	15.00	12.50	29000	21,500	8.50	26200	3.6	17,000	2.50	1050
	E*1P29A+H4TXV01	A80DF1E045A12	14.50	12.50	29000	21,500	8.50	26200	3.6	17,000	2.50	1050
	E*1P29A+H4TXV01	A80UH2V070A12*	15.00	12.50	29000	21,500	8.50	26200	3.6	17,000	2.50	1050
	E*1P29A+H4TXV01	A80DF2V070A12*	15.00	12.50	29000	21,500	8.50	26200	3.6	17,000	2.50	1050
	E*1P29B+H4TXV01	A80UH2V090B16*	14.50	12.50	29000	21,500	8.50	26200	3.6	17,000	2.50	1050
	E*1P29B+H4TXV01	A80UH2V090B12*	15.00	12.50	29000	21,500	8.50	26200	3.6	17,000	2.50	1050
	E*1P29B+H4TXV01	A80DF2V090B16*	15.00	12.50	29000	21,500	8.50	26200	3.6	17,000	2.50	1050
	E*1P29B+H4TXV01	A80DF1E070B12	14.50	12.50	29000	21,500	8.50	26200	3.6	17,000	2.50	1050
	E*1P29B+H4TXV01	A80UH1E070B12*	14.50	12.50	29000	21,500	8.50	26200	3.6	17,000	2.50	1050
	E*1P29B+H4TXV01	A97DSMV070B12*	14.50	12.50	29000	21,500	8.50	26200	3.6	17,000	2.50	1050
	E*1P29B+H4TXV01	A80DF1E090B16	14.50	12.50	29000	21,500	8.50	26200	3.6	17,000	2.50	1050
	E*1P29B+H4TXV01	A97USMV070B12*	15.00	12.50	29000	21,500	8.50	26200	3.6	17,000	2.50	1050
	E*1P29B+H4TXV01	A80UH1E090B16*	14.50	12.50	29000	21,500	8.50	26200	3.6	17,000	2.50	1050
	E*1P29B+H4TXV01	A95UH2V070B12S	14.50	12.50	29000	21,500	8.50	26200	3.6	17,000	2.50	1050
	E*1P29B+H4TXV01	A80US2V090B16*	14.50	12.50	29000	21,500	8.50	26200	3.6	17,000	2.50	1050
	E*1P29B+H4TXV01	EFV12BC	14.50	12.50	29000	21,500	8.50	26200	3.6	17,000	2.50	1050
E*1P29B+H4TXV01	A95UH1E070B12S	14.00	12.00	29000	21,500	8.50	26200	3.6	17,000	2.50	1050	

Note:

1. Certified in accordance with Unitary Air Conditioner Certification Program, which is based on AHRI Standard 210/240
2. Required to achieve AHRI rating. If NA (Not Applicable) is in the piston column, then TXV is required.
3. A blower time delay relay is required to achieve AHRI rating. This feature is standard on all Allied Air Enterprises furnace and AH products.

**COOLING PERFORMANCE WITH AIR HANDLERS AND FURNACES**

Outdoor Model	Indoor Model	Furnace	Cooling				Heating				CFM	
	Evap. Coil <sup>3</sup>		SEER	EER	AHRI Rated Capacity <sup>1</sup> BTUH	Sensible Capacity BTUH	HSPF	47°		17°		
								Btuh	COP	Btuh		COP
4SHP14L*13OP-7	E*1P29B+H4TXV01	A95DF2V045B12S	14.50	12.50	29000	21,500	8.50	26200	3.6	17,000	2.50	1050
	E*1P29B+H4TXV01	L83UF1V84/95E14	14.50	12.50	29000	21,500	8.20	26000	3.6	17,000	2.50	1050
	E*1P29B+H4TXV01	L83HR1V84/95E12	14.00	12.00	28800	21,500	8.20	26200	3.6	17,000	2.50	1050
	E*1P29B+H4TXV01	L83HF1V84/95E12	14.00	12.00	28800	21,500	8.20	26200	3.6	17,000	2.50	1050
	E*1P29B+H4TXV01	A80US2V090B12*	15.00	12.50	29000	21,500	8.50	26200	3.6	17,000	2.50	1050
	E*1P29B+H4TXV01	L83UF1V57/72E12	14.50	12.50	29000	21,500	8.20	26000	3.6	17,000	2.50	1050
	E*1P29B+H4TXV01	A80DS2V090B16*	15.00	12.50	29000	21,500	8.50	26200	3.6	17,000	2.50	1050
	E*1P29B+H4TXV01	L83B*1V84/95E14	14.50	12.50	29000	21,500	8.20	26000	3.6	17,000	2.50	1050
	E*1P29B+H4TXV01	L85UF1V67/87E14	14.50	12.50	28600	21,500	8.20	26000	3.6	17,000	2.50	1050
	E*1P29B+H4TXV01	A96DS2V045B12S	14.50	12.50	29000	21,500	8.50	26200	3.6	17,000	2.50	1050
	E*1P29B+H4TXV01	A96US2V070B12S	14.50	12.50	29000	21,500	8.50	26200	3.6	17,000	2.50	1050
	E*1P30A+H4TXV01	A80US2V070A12*	14.50	12.50	28000	21,500	8.50	26200	3.6	15600	2.50	1050
	E*1P30A+H4TXV01	A80DS2V070A12*	14.50	12.50	28000	21,500	8.50	26200	3.6	15600	2.50	1050
	E*1P30A+H4TXV01	A80UH2V070A12*	14.50	12.50	28000	21,500	8.50	26200	3.6	15600	2.50	1050
	E*1P30A+H4TXV01	A80DF2V070A12*	14.50	12.50	28000	21,500	8.50	26200	3.6	15600	2.50	1050
	E*1P30B+H4TXV01	A80DF2V090B16*	14.50	12.50	28000	21,500	8.50	26200	3.6	15600	2.50	1050
	E*1P30B+H4TXV01	A80UH1E090B16*	14.00	12.00	28000	21,500	8.50	26200	3.6	15600	2.50	1050
	E*1P30B+H4TXV01	A80UH2V090B12*	15.00	12.50	28000	21,500	8.50	26200	3.6	15500	2.50	1050
	E*1P30B+H4TXV01	A80DS2V090B16*	14.50	12.50	28000	21,500	8.50	26200	3.6	15600	2.50	1050
	E*1P30B+H4TXV01	A80US2V090B12*	15.00	12.50	28000	21,500	8.50	26200	3.6	15500	2.50	1050
	E*1P30B+H4TXV01	L83UF1V84/95E14	14.00	12.00	28000	21,500	8.20	26000	3.6	15600	2.50	1050
	E*1P30B+H4TXV01	L83UF1V57/72E12	14.00	12.00	28000	21,500	8.20	26000	3.6	15600	2.50	1050
	E*1P30B+H4TXV01	A97DSMV070B12*	14.50	12.50	28000	21,500	8.50	26200	3.6	15600	2.50	1050
	E*1P30B+H4TXV01	L83B*1V84/95E14	14.00	12.00	28000	21,500	8.20	26000	3.6	15500	2.50	1050
	E*1P30B+H4TXV01	L83HR1V84/95E12	14.00	12.00	28000	21,500	8.20	26000	3.6	15600	2.50	1050
	E*1P30B+H4TXV01	A97USMV070B12*	14.50	12.50	28000	21,500	8.50	26200	3.6	15600	2.50	1050
	E*1P30C+H4TXV01	A97USMV090C12*	15.00	12.50	28000	21,500	8.50	26200	3.6	15600	2.50	1050
	E*1P30C+H4TXV01	A97DSMV090C16*	14.50	12.50	28000	21,500	8.50	26200	3.6	15600	2.50	1050
	E*1P30C+H4TXV01	A80DS2V110C20*	15.00	12.50	28000	21,500	8.50	26200	3.6	15500	2.50	1050
	E*1P30C+H4TXV01	A80US2V090C20*	15.00	12.50	28000	21,500	8.50	26200	3.6	15500	2.50	1050
	E*1P30C+H4TXV01	A96DS2V090C20S	14.50	12.00	28000	21,500	8.50	26200	3.6	15600	2.50	1050
	E*1P30C+H4TXV01	A96US2V090C12S	14.50	12.50	28000	21,500	8.50	26200	3.6	15600	2.50	1050
	E*1P30C+H4TXV01	L85UF1V67/87E14	14.00	12.00	28000	21,500	8.20	26000	3.6	15600	2.50	1050
	E*1P30C+H4TXV01	L85B*1V67/87E14	14.00	12.00	28000	21,500	8.20	26000	3.6	15600	2.50	1050
	E*1P30C+H4TXV01	EFV16CC	14.50	12.50	28000	21,500	8.50	26200	3.6	15600	2.50	1050
	E*1P30C+H4TXV01	A80UH2V090C20*	15.00	12.50	28000	21,500	8.50	26200	3.6	15500	2.50	1050
	E*1P30C+H4TXV01	A95UH2V090C12S	14.50	12.50	28000	21,500	8.50	26200	3.6	15600	2.50	1050
	E*1P30C+H4TXV01	A95UH1E090C16S	14.50	12.00	28000	21,500	8.50	26200	3.6	15600	2.50	1050
	E*1P30C+H4TXV01	A95DF2V090C20S	14.50	12.00	28000	21,500	8.50	26200	3.6	15600	2.50	1050
	E*1P30C+H4TXV01	A80DF2V110C20*	15.00	12.50	28000	21,500	8.50	26200	3.6	15500	2.50	1050
E*1P36A+H4TXV01	A80DF2V070A12*	15.00	12.50	29000	21,500	8.50	26200	3.6	17,000	2.50	1050	
E*1P36A+H4TXV01	A80UH2V070A12*	15.00	12.50	29000	21,500	8.50	26200	3.6	17,000	2.50	1050	
E*1P36A+H4TXV01	A80DF1E045A12	14.50	12.50	29000	21,500	8.50	26200	3.6	17,000	2.50	1050	
E*1P36A+H4TXV01	A80US2V070A12*	15.00	12.50	29000	21,500	8.50	26200	3.6	17,000	2.50	1050	

Note:

1. Certified in accordance with Unitary Air Conditioner Certification Program, which is based on AHRI Standard 210/240
2. Required to achieve AHRI rating. If NA (Not Applicable) is in the piston column, then TXV is required.
3. A blower time delay relay is required to achieve AHRI rating. This feature is standard on all Allied Air Enterprises furnace and AH products.



**COOLING PERFORMANCE WITH AIR HANDLERS AND FURNACES**

Outdoor Model	Indoor Model	Furnace	Cooling				Heating				CFM	
	Evap. Coil <sup>3</sup>		SEER	EER	AHRI Rated Capacity <sup>1</sup> BTUH	Sensible Capacity BTUH	HSPF	47°		17°		
								Btuh	COP	Btuh		COP
4SHP14L*13OP-7	E*1P36A+H4TXV01	A80DS2V070A12*	15.00	12.50	29000	21,500	8.50	26200	3.6	17,000	2.50	1050
	E*1P36B+H4TXV01	L83B*1V84/95E14	14.50	12.50	29000	21,500	8.50	26200	3.6	17,000	2.50	1050
	E*1P36B+H4TXV01	A80DS2V090B16*	15.00	12.50	29000	21,500	8.50	26200	3.6	17,000	2.50	1050
	E*1P36B+H4TXV01	L83UF1V57/72E12	14.50	12.50	29000	21,500	8.50	26200	3.6	17,000	2.50	1050
	E*1P36B+H4TXV01	A80DF1E090B16	14.50	12.50	29000	21,500	8.50	26200	3.6	17,000	2.50	1050
	E*1P36B+H4TXV01	A97DSMV070B12*	15.00	12.50	29000	21,500	8.50	26200	3.6	17,000	2.50	1050
	E*1P36B+H4TXV01	L83HF1V84/95E12	14.00	12.00	29000	21,500	8.50	26200	3.6	17,000	2.50	1050
	E*1P36B+H4TXV01	L83HR1V84/95E12	14.00	12.00	29000	21,500	8.50	26200	3.6	17,000	2.50	1050
	E*1P36B+H4TXV01	L83UF1V84/95E14	14.50	12.50	29000	21,500	8.50	26200	3.6	17,000	2.50	1050
	E*1P36B+H4TXV01	A80US2V090B12*	15.00	12.50	29000	21,500	8.50	26200	3.6	17,000	2.50	1050
	E*1P36B+H4TXV01	A96DS2V045B12S	14.50	12.50	29000	21,500	8.50	26200	3.6	17,000	2.50	1050
	E*1P36B+H4TXV01	A96US2V070B12S	14.50	12.50	29000	21,500	8.50	26200	3.6	17,000	2.50	1050
	E*1P36B+H4TXV01	A95DF2V045B12S	14.50	12.50	29000	21,500	8.50	26200	3.6	17,000	2.50	1050
	E*1P36B+H4TXV01	A80DF1E070B12	14.50	12.50	29000	21,500	8.50	26200	3.6	17,000	2.50	1050
	E*1P36B+H4TXV01	A80UH2V090B16*	14.50	12.50	29000	21,500	8.50	26200	3.6	17,000	2.50	1050
	E*1P36B+H4TXV01	EFV12BC	14.50	12.50	29000	21,500	8.50	26200	3.6	17,000	2.50	1050
	E*1P36B+H4TXV01	A80UH2V090B12*	15.00	12.50	29000	21,500	8.50	26200	3.6	17,000	2.50	1050
	E*1P36B+H4TXV01	A80UH1E070B12*	14.50	12.50	29000	21,500	8.50	26200	3.6	17,000	2.50	1050
	E*1P36B+H4TXV01	A97USMV070B12*	15.00	12.50	29000	21,500	8.50	26200	3.6	17,000	2.50	1050
	E*1P36B+H4TXV01	A95UH2V070B12S	14.50	12.50	29000	21,500	8.50	26200	3.6	17,000	2.50	1050
	E*1P36B+H4TXV01	A95UH1E070B12S	14.00	12.00	29000	21,500	8.50	26200	3.6	17,000	2.50	1050
	E*1P36B+H4TXV01	A80US2V090B16*	14.50	12.50	29000	21,500	8.50	26200	3.6	17,000	2.50	1050
	E*1P36B+H4TXV01	A80UH1E090B16*	14.00	12.00	29000	21,500	8.50	26200	3.6	17,000	2.50	1050
	E*1P36B+H4TXV01	A80DF2V090B16*	15.00	12.50	29000	21,500	8.50	26200	3.6	17,000	2.50	1050
	E*1P36C+H4TXV01	A80UH2V090C20*	15.00	12.50	29000	21,500	8.50	26200	3.6	17,000	2.50	1050
	E*1P36C+H4TXV01	A95DF1E090C16S	14.50	12.50	29000	21,500	8.50	26200	3.6	17,000	2.50	1050
	E*1P36C+H4TXV01	A97DSMV090C16*	15.00	12.50	29000	21,500	8.50	26200	3.6	17,000	2.50	1050
	E*1P36C+H4TXV01	A95UH1E090C16S	14.50	12.50	29000	21,500	8.50	26200	3.6	17,000	2.50	1050
	E*1P36C+H4TXV01	A97USMV090C12*	15.00	12.50	29000	21,500	8.50	26200	3.6	17,000	2.50	1050
	E*1P36C+H4TXV01	EFV16CC	14.50	12.50	29000	21,500	8.50	26200	3.6	17,000	2.50	1050
	E*1P36C+H4TXV01	A80DF2V110C20*	15.00	12.50	29000	21,500	8.50	26200	3.6	17,000	2.50	1050
	E*1P36C+H4TXV01	A95DF2V110C20S	14.50	12.50	29000	21,500	8.50	26200	3.6	17,000	2.50	1050
	E*1P36C+H4TXV01	A95DF2V090C20S	14.50	12.50	29000	21,500	8.50	26200	3.6	17,000	2.50	1050
	E*1P36C+H4TXV01	A95UH2V090C12S	15.00	12.50	29000	21,500	8.50	26200	3.6	17,000	2.50	1050
	E*1P36C+H4TXV01	A96DS2V090C20S	14.50	12.50	29000	21,500	8.50	26200	3.6	17,000	2.50	1050
	E*1P36C+H4TXV01	A96DS2V110C20S	14.50	12.50	29000	21,500	8.50	26200	3.6	17,000	2.50	1050
	E*1P36C+H4TXV01	A96US2V090C12S	15.00	12.50	29000	21,500	8.50	26200	3.6	17,000	2.50	1050
	E*1P36C+H4TXV01	L85B*1V67/87E14	14.00	12.50	28600	21,500	8.50	26000	3.6	17,000	2.50	1050
	E*1P36C+H4TXV01	L85UF1V67/87E14	14.50	12.50	28600	21,500	8.50	26000	3.6	17,000	2.50	1050
	E*1P36C+H4TXV01	A80DS2V110C20*	15.00	12.50	29000	21,500	8.50	26200	3.6	17,000	2.50	1050
E*1P36C+H4TXV01	A80US2V090C20*	15.00	12.50	29000	21,500	8.50	26200	3.6	17,000	2.50	1050	

Note:

1. Certified in accordance with Unitary Air Conditioner Certification Program, which is based on AHRI Standard 210/240
2. Required to achieve AHRI rating. If NA (Not Applicable) is in the piston column, then TXV is required.
3. A blower time delay relay is required to achieve AHRI rating. This feature is standard on all Allied Air Enterprises furnace and AH products.

**COOLING PERFORMANCE WITH AIR HANDLERS AND FURNACES**

Outdoor Model	Indoor Model	Furnace	Cooling				Heating				CFM		
	Evap. Coil <sup>3</sup>		SEER	EER	AHRI Rated Capacity <sup>1</sup> BTUH	Sensible Capacity BTUH	HSPF	47°		17°			
								Btuh	COP	Btuh		COP	
4SHP14L*136P-7	BCE3M36C****P+H4TXV02		14.00	12.00	34000	26,000	8.20	33800	3.5	21800	2.50	1250	
	BCE3M36E****X		15.00	12.50	34000	26,000	8.50	33800	3.6	21800	2.50	1250	
	BCE3M42E****X		15.00	12.00	34000	26,000	8.20	33800	3.6	21800	2.50	1200	
	BCS2M36S00NA1P+H4TXV02		15.00	12.50	34000	26,000	8.50	33800	3.6	21600	2.50	1250	
	BCS2M36V00NA1P+H4TXV02		15.00	12.50	34000	26,000	8.50	33800	3.6	21600	2.50	1250	
	E*1P36A+H4TXV02	A80UH2V070A12*		14.50	12.50	34000	26,000	8.20	33800	3.6	21200	2.50	1250
	E*1P36A+H4TXV02	A80US2V070A12*		14.50	12.50	34000	26,000	8.20	33800	3.6	21200	2.50	1250
	E*1P36B+H4TXV02	A80US2V090B12*		14.50	12.50	34000	26,000	8.20	33800	3.6	21200	2.50	1250
	E*1P36B+H4TXV02	L83B*1V112/125F20		14.00	12.00	34000	26,000	8.20	33800	3.6	21200	2.50	1250
	E*1P36B+H4TXV02	L83UF1V112/125F20		14.00	12.00	34000	26,000	8.20	33800	3.6	21200	2.50	1250
	E*1P36B+H4TXV02	A80UH2V090B12*		14.50	12.50	34000	26,000	8.20	33800	3.6	21200	2.50	1250
	E*1P36B+H4TXV02	A80DF1E090B16		14.00	12.00	34000	26,000	8.50	33800	3.6	21200	2.50	1275
	E*1P36B+H4TXV02	A80UH1E090B16*		14.50	12.50	34000	26,000	8.50	33800	3.6	21200	2.50	1250
	E*1P36B+H4TXV02	EFV12BC		14.50	12.50	34000	26,000	8.50	33800	3.6	21200	2.50	1250
	E*1P36C+H4TXV02	EFV16CC		15.00	12.50	34000	26,000	8.50	33800	3.6	21000	2.50	1250
	E*1P36C+H4TXV02	A80UH2V110C20*		14.50	12.50	34000	26,000	8.50	33800	3.6	21200	2.50	1250
	E*1P36C+H4TXV02	A80DF2V110C20*		14.50	12.50	34000	26,000	8.50	33800	3.6	21200	2.50	1250
	E*1P36C+H4TXV02	A80UH2V090C20*		14.50	12.50	34000	26,000	8.50	33800	3.6	21200	2.50	1250
	E*1P36C+H4TXV02	A95DF1E110C20S		14.00	12.00	34000	26,000	8.50	33800	3.6	21200	2.50	1275
	E*1P36C+H4TXV02	A95UH2V090C16S		14.50	12.50	34000	26,000	8.50	33800	3.6	21200	2.50	1250
	E*1P36C+H4TXV02	A95UH2V110C16S		14.50	12.50	34000	26,000	8.50	33800	3.6	21200	2.50	1250
	E*1P36C+H4TXV02	A80UH1E110C20*		14.00	12.00	34000	26,000	8.50	33800	3.6	21200	2.50	1275
	E*1P36C+H4TXV02	A97USMV090C16*		14.50	12.50	34000	26,000	8.50	33800	3.6	21200	2.50	1250
	E*1P36C+H4TXV02	A80DF1E110C20		14.00	12.00	34000	26,000	8.50	33800	3.6	21200	2.50	1275
	E*1P36C+H4TXV02	A97DSMV090C16*		14.50	12.50	34000	26,000	8.20	33800	3.6	21200	2.50	1250
	E*1P36C+H4TXV02	A97DSMV110C20*		14.50	12.50	34000	26,000	8.20	33800	3.6	21200	2.50	1250
	E*1P36C+H4TXV02	A97DSMV090C20*		14.50	12.50	34000	26,000	8.20	33800	3.6	21200	2.50	1250
	E*1P36C+H4TXV02	A95UH2V090C12S		14.50	12.50	34000	26,000	8.20	33800	3.6	21200	2.50	1250
	E*1P36C+H4TXV02	A95DF2V090C20S		14.50	12.50	34000	26,000	8.20	33800	3.6	21200	2.50	1250
	E*1P36C+H4TXV02	A95UH2V090C20S		14.50	12.50	34000	26,000	8.50	33800	3.6	21200	2.50	1250
	E*1P36C+H4TXV02	A80UH1E090C20*		14.00	12.00	34000	26,000	8.50	33800	3.6	21200	2.50	1275
	E*1P36C+H4TXV02	A95UH2V110C20S		14.50	12.50	34000	26,000	8.50	33800	3.6	21200	2.50	1250
	E*1P36C+H4TXV02	A80US2V090C20*		14.50	12.50	34000	26,000	8.50	33800	3.6	21200	2.50	1250
	E*1P36C+H4TXV02	A80US2V110C20*		14.50	12.50	34000	26,000	8.50	33800	3.6	21200	2.50	1250
	E*1P36C+H4TXV02	A80DS2V110C20*		14.50	12.50	34000	26,000	8.50	33800	3.6	21200	2.50	1250
	E*1P36C+H4TXV02	A97USMV090C12*		14.50	12.50	34000	26,000	8.20	33800	3.6	21200	2.50	1250
	E*1P36C+H4TXV02	A97USMV110C20*		14.50	12.50	34000	26,000	8.20	33800	3.6	21200	2.50	1250
	E*1P36C+H4TXV02	A95UH1E110C20S		14.00	12.00	34000	26,000	8.50	33800	3.6	21200	2.50	1275
	E*1P36C+H4TXV02	L85B*1V104/118F20		14.50	12.50	34000	26,000	8.20	33800	3.6	21200	2.50	1250
	E*1P36C+H4TXV02	A96DS2V090C20S		14.50	12.50	34000	26,000	8.20	33800	3.6	21200	2.50	1250
	E*1P36C+H4TXV02	A96US2V090C12S		14.50	12.50	34000	26,000	8.20	33800	3.6	21200	2.50	1250
	E*1P36C+H4TXV02	A96US2V090C16S		14.50	12.50	34000	26,000	8.50	33800	3.6	21200	2.50	1250
E*1P36C+H4TXV02	A96US2V090C20S		14.50	12.50	34000	26,000	8.50	33800	3.6	21200	2.50	1250	
E*1P36C+H4TXV02	A96US2V110C16S		14.50	12.50	34000	26,000	8.50	33800	3.6	21200	2.50	1250	

Note:

1. Certified in accordance with Unitary Air Conditioner Certification Program, which is based on AHRI Standard 210/240
2. Required to achieve AHRI rating. If NA (Not Applicable) is in the piston column, then TXV is required.
3. A blower time delay relay is required to achieve AHRI rating. This feature is standard on all Allied Air Enterprises furnace and AH products.

**COOLING PERFORMANCE WITH AIR HANDLERS AND FURNACES**

Outdoor Model	Indoor Model	Furnace	Cooling				Heating				CFM	
	Evap. Coil <sup>3</sup>		SEER	EER	AHRI Rated Capacity <sup>1</sup> BTUH	Sensible Capacity BTUH	HSPF	47°		17°		
								Btuh	COP	Btuh		COP
4SHP14L*136P-7	E*1P36C+H4TXV02	A96US2V110C20S	14.50	12.50	34000	26,000	8.50	33800	3.6	21200	2.50	1250
	E*1P43B+H4TXV02	L83UF1V112/125F20	14.00	12.00	34000	26,000	8.20	33800	3.6	21800	2.50	1250
	E*1P43B+H4TXV02	A80DS2V090B16*	14.50	12.50	34000	26,000	8.50	33800	3.6	21800	2.50	1250
	E*1P43B+H4TXV02	A80US2V090B12*	14.50	12.50	34000	26,000	8.50	33800	3.6	21800	2.50	1250
	E*1P43B+H4TXV02	L83B*1V112/125F20	14.00	12.00	34000	26,000	8.20	33800	3.6	21800	2.50	1250
	E*1P43B+H4TXV02	A80UH2V090B12*	14.50	12.50	34000	26,000	8.50	33800	3.6	21800	2.50	1250
	E*1P43B+H4TXV02	A80DF2V090B16*	14.50	12.50	34000	26,000	8.50	33800	3.6	21800	2.50	1250
	E*1P43B+H4TXV02	A80UH1E090B16*	14.50	12.50	34000	26,000	8.50	33800	3.6	21800	2.50	1250
	E*1P43B+H4TXV02	A80DF1E090B16	14.00	12.00	34000	26,000	8.50	33800	3.6	21800	2.50	1275
	E*1P43B+H4TXV02	EFV12BC	14.50	12.50	34000	26,000	8.50	33800	3.6	21800	2.50	1250
	E*1P43C+H4TXV02	A97USMV090C12*	14.50	12.50	34000	26,000	8.50	33800	3.6	21800	2.50	1250
	E*1P43C+H4TXV02	A95UH2V110C16S	14.50	12.50	34000	26,000	8.50	33800	3.6	21800	2.50	1250
	E*1P43C+H4TXV02	A95UH1E110C20S	14.00	12.00	34000	26,000	8.50	33800	3.6	21800	2.50	1250
	E*1P43C+H4TXV02	A80UH2V090C20*	14.50	12.50	34000	26,000	8.50	33800	3.6	21800	2.50	1250
	E*1P43C+H4TXV02	A95UH2V110C20S	14.50	12.50	34000	26,000	8.50	33800	3.6	21800	2.50	1250
	E*1P43C+H4TXV02	A97DSMV090C16*	14.50	12.50	34000	26,000	8.50	33800	3.6	21800	2.50	1250
	E*1P43C+H4TXV02	A95UH2V090C16S	14.50	12.50	34000	26,000	8.50	33800	3.6	21800	2.50	1250
	E*1P43C+H4TXV02	A95UH2V090C20S	14.50	12.50	34000	26,000	8.50	33800	3.6	21800	2.50	1250
	E*1P43C+H4TXV02	A95DF1E110C20S	14.00	12.00	34000	26,000	8.50	33800	3.6	21800	2.50	1275
	E*1P43C+H4TXV02	A95UH2V090C12S	14.50	12.50	34000	26,000	8.50	33800	3.6	21800	2.50	1250
	E*1P43C+H4TXV02	A80DF1E110C20	14.50	12.50	34000	26,000	8.50	33800	3.6	21800	2.50	1275
	E*1P43C+H4TXV02	A95DF2V090C20S	14.00	12.50	34000	26,000	8.50	33800	3.6	21800	2.50	1250
	E*1P43C+H4TXV02	A97DSMV090C20*	14.50	12.50	34000	26,000	8.50	33800	3.6	21800	2.50	1250
	E*1P43C+H4TXV02	A80DF2V110C20*	14.50	12.50	34000	26,000	8.50	33800	3.6	21800	2.50	1250
	E*1P43C+H4TXV02	A80UH2V110C20*	14.50	12.50	34000	26,000	8.50	33800	3.6	21800	2.50	1250
	E*1P43C+H4TXV02	EFV16CC	15.00	12.50	34000	26,000	8.50	33800	3.6	21800	2.50	1250
	E*1P43C+H4TXV02	A80US2V090C20*	14.50	12.50	34000	26,000	8.50	33800	3.6	21800	2.50	1250
	E*1P43C+H4TXV02	A80DS2V110C20*	14.50	12.50	34000	26,000	8.50	33800	3.6	21800	2.50	1250
	E*1P43C+H4TXV02	A97DSMV110C20*	14.50	12.50	34000	26,000	8.50	33800	3.6	21800	2.50	1250
	E*1P43C+H4TXV02	A80US2V110C20*	14.50	12.50	34000	26,000	8.50	33800	3.6	21800	2.50	1250
	E*1P43C+H4TXV02	A80UH1E110C20*	14.50	12.50	34000	26,000	8.50	33800	3.6	21800	2.50	1275
	E*1P43C+H4TXV02	A97USMV110C20*	14.50	12.50	34000	26,000	8.50	33800	3.6	21800	2.50	1250
	E*1P43C+H4TXV02	A95DF2V110C20S	14.00	12.50	34000	26,000	8.50	33800	3.6	21800	2.50	1275
	E*1P43C+H4TXV02	A80UH1E090C20*	14.50	12.50	34000	26,000	8.50	33800	3.6	21800	2.50	1275
	E*1P43C+H4TXV02	A97USMV090C16*	14.50	12.50	34000	26,000	8.50	33800	3.6	21800	2.50	1250
	E*1P43C+H4TXV02	A96DS2V090C20S	14.00	12.50	34000	26,000	8.50	33800	3.6	21800	2.50	1250
	E*1P43C+H4TXV02	A96DS2V110C20S	14.00	12.50	34000	26,000	8.50	33800	3.6	21800	2.50	1275
	E*1P43C+H4TXV02	A96US2V090C12S	14.50	12.50	34000	26,000	8.50	33800	3.6	21800	2.50	1250
	E*1P43C+H4TXV02	A96US2V090C16S	14.50	12.50	34000	26,000	8.50	33800	3.6	21800	2.50	1250
	E*1P43C+H4TXV02	A96US2V090C20S	14.50	12.50	34000	26,000	8.50	33800	3.6	21800	2.50	1250
E*1P43C+H4TXV02	A96US2V110C16S	14.50	12.50	34000	26,000	8.50	33800	3.6	21800	2.50	1250	
E*1P43C+H4TXV02	A96US2V110C20S	14.50	12.50	34000	26,000	8.50	33800	3.6	21800	2.50	1250	
E*1P43C+H4TXV02	L85B*1V104/118F20	14.00	12.00	34600	26,000	8.20	33800	3.6	21800	2.50	1275	

Note:

1. Certified in accordance with Unitary Air Conditioner Certification Program, which is based on AHRI Standard 210/240
2. Required to achieve AHRI rating. If NA (Not Applicable) is in the piston column, then TXV is required.
3. A blower time delay relay is required to achieve AHRI rating. This feature is standard on all Allied Air Enterprises furnace and AH products.

**COOLING PERFORMANCE WITH AIR HANDLERS AND FURNACES**

Outdoor Model	Indoor Model	Furnace	Cooling				Heating				CFM		
	Evap. Coil <sup>3</sup>		SEER	EER	AHRI Rated Capacity <sup>1</sup> BTUH	Sensible Capacity BTUH	HSPF	47°		17°			
								Btuh	COP	Btuh		COP	
4SHP14L*142P-7	BCE3M42C****P+H4TXV02		14.00	12.00	41000	30,700	8.20	40000	3.5	28800	2.40	1400	
	BCE3M42E****X		15.00	12.50	41000	30,700	8.50	40000	3.6	28800	2.40	1400	
	BCS2M42S00NA1P+H4TXV02		15.00	12.50	41000	30,700	8.50	40000	3.6	28000	2.40	1400	
	BCS2M42V00NA1P+H4TXV02		15.00	12.50	41000	30,700	8.50	40000	3.6	28000	2.40	1400	
	E*1P49C+H4TXV02	A95UH1E110C20S		15.00	12.50	41000	30,700	8.50	40000	3.6	27200	2.40	1400
	E*1P49C+H4TXV02	A80UH2V110C20*		15.00	12.50	41000	30,700	8.50	40000	3.6	27200	2.40	1400
	E*1P49C+H4TXV02	A80UH2V090C20*		15.00	12.50	41000	30,700	8.50	40000	3.6	27200	2.40	1400
	E*1P49C+H4TXV02	A80DF2V110C20*		15.00	12.50	41000	30,700	8.50	40000	3.6	27200	2.40	1400
	E*1P49C+H4TXV02	EFV16CC		14.50	12.50	41000	30,700	8.50	40000	3.6	27200	2.40	1400
	E*1P49C+H4TXV02	A95UH2V090C16S		15.00	12.50	41000	30,700	8.50	40000	3.6	27200	2.40	1400
	E*1P49C+H4TXV02	A95UH2V090C20S		15.00	12.50	41000	30,700	8.50	40000	3.6	27200	2.40	1400
	E*1P49C+H4TXV02	A95DF1E110C20S		15.00	12.50	41000	30,700	8.50	40000	3.6	27200	2.40	1400
	E*1P49C+H4TXV02	A80UH1E090C20*		15.00	12.50	41000	30,700	8.50	40000	3.6	27200	2.40	1400
	E*1P49C+H4TXV02	A97DSMV110C20*		15.00	12.50	41000	30,700	8.50	40000	3.6	27200	2.40	1400
	E*1P49C+H4TXV02	A80DF1E110C20		15.00	12.50	41000	30,700	8.50	40000	3.6	27200	2.40	1400
	E*1P49C+H4TXV02	A97USMV110C20*		15.00	12.50	41000	30,700	8.50	40000	3.6	27200	2.40	1400
	E*1P49C+H4TXV02	A97USMV090C20*		15.00	12.50	41000	30,700	8.50	40000	3.6	27200	2.40	1400
	E*1P49C+H4TXV02	A95UH2V110C20S		15.00	12.50	41000	30,700	8.50	40000	3.6	27200	2.40	1400
	E*1P49C+H4TXV02	A80UH1E110C20*		15.00	12.50	41000	30,700	8.50	40000	3.6	27200	2.40	1400
	E*1P49C+H4TXV02	A95UH1E090C16S		14.50	12.50	41000	30,700	8.20	40000	3.6	27200	2.40	1400
	E*1P49C+H4TXV02	L83UF1V112/125F20		14.00	12.00	42000	30,700	8.20	42000	3.6	27200	2.40	1400
	E*1P49C+H4TXV02	A97USMV090C16*		15.00	12.50	41000	30,700	8.50	40000	3.6	27200	2.40	1400
	E*1P49C+H4TXV02	L83B*1V84/95E14		14.00	12.00	42000	30,700	8.20	42000	3.6	27200	2.40	1400
	E*1P49C+H4TXV02	L83B*1V112/125F20		14.00	12.00	42000	30,700	8.20	42000	3.6	27200	2.40	1400
	E*1P49C+H4TXV02	L83UF1V84/95E14		14.00	12.00	42000	30,700	8.20	42000	3.6	27200	2.40	1400
	E*1P49C+H4TXV02	A97DSMV090C16*		15.00	12.50	41000	30,700	8.50	40000	3.6	27200	2.40	1400
	E*1P49C+H4TXV02	A95DF2V110C20S		14.50	12.50	41000	30,700	8.20	40000	3.6	27200	2.40	1400
	E*1P49C+H4TXV02	A95DF2V090C20S		14.50	12.50	41000	30,700	8.20	40000	3.6	27200	2.40	1400
	E*1P49C+H4TXV02	A95UH2V110C16S		15.00	12.50	41000	30,700	8.50	40000	3.6	27200	2.40	1400
	E*1P49C+H4TXV02	A97DSMV090C20*		14.50	12.50	41000	30,700	8.50	40000	3.6	27200	2.40	1400
	E*1P49C+H4TXV02	A80US2V110C20*		15.00	12.50	41000	30,700	8.50	40000	3.6	27200	2.40	1400
	E*1P49C+H4TXV02	A80US2V090C20*		15.00	12.50	41000	30,700	8.50	40000	3.6	27200	2.40	1400
	E*1P49C+H4TXV02	A80DS2V110C20*		15.00	12.50	41000	30,700	8.50	40000	3.6	27200	2.40	1400
	E*1P49C+H4TXV02	A95DF2E090C16S		15.00	12.50	41000	30,700	8.50	40000	3.6	27200	2.40	1400
	E*1P49C+H4TXV02	A95UH2E090C16S		15.00	12.50	41000	30,700	8.20	40000	3.6	27200	2.40	1400
	E*1P49C+H4TXV02	L85B*1V104/118F20		14.00	12.00	41000	30,700	8.20	40000	3.6	27200	2.40	1400
	E*1P49C+H4TXV02	L85UF1V104/118F14		14.00	12.00	41000	30,700	8.20	40000	3.6	27200	2.40	1400
	E*1P49C+H4TXV02	A95DF2E110C20S		15.00	12.50	41000	30,700	8.50	40000	3.6	27200	2.40	1400
	E*1P49C+H4TXV02	A95UH2E110C20S		15.00	12.50	41000	30,700	8.20	40000	3.6	27200	2.40	1400
	E*1P49C+H4TXV02	L85B*1V67/87E14		14.00	12.00	41000	30,700	8.20	40000	3.6	27200	2.40	1400
E*1P49C+H4TXV02	L85UF1V67/87E14		14.00	12.00	41000	30,700	8.20	40000	3.6	27200	2.40	1400	
E*1P49C+H4TXV02	A96US2V090C16S		15.00	12.50	41000	30,700	8.50	40000	3.6	27200	2.40	1400	
E*1P49C+H4TXV02	A96US2V090C20S		15.00	12.50	41000	30,700	8.50	40000	3.6	27200	2.40	1400	
E*1P49C+H4TXV02	A96US2V110C16S		15.00	12.50	41000	30,700	8.50	40000	3.6	27200	2.40	1400	

Note:

1. Certified in accordance with Unitary Air Conditioner Certification Program, which is based on AHRI Standard 210/240
2. Required to achieve AHRI rating. If NA (Not Applicable) is in the piston column, then TXV is required.
3. A blower time delay relay is required to achieve AHRI rating. This feature is standard on all Allied Air Enterprises furnace and AH products.

**COOLING PERFORMANCE WITH AIR HANDLERS AND FURNACES**

Outdoor Model	Indoor Model	Furnace	Cooling				Heating				CFM	
	Evap. Coil <sup>3</sup>		SEER	EER	AHRI Rated Capacity <sup>1</sup> BTUH	Sensible Capacity BTUH	HSPF	47°		17°		
								Btuh	COP	Btuh		COP
<b>4SHP14L*142P-7</b>	E*1P49C+H4TXV02	A96US2V110C20S	15.00	12.50	41000	30,700	8.50	40000	3.6	27200	2.40	1400
	E*1P49C+H4TXV02	A96DS2V090C20S	14.50	12.50	41000	30,700	8.20	40000	3.6	27200	2.40	1400
	E*1P49C+H4TXV02	A96DS2V110C20S	14.50	12.50	41000	30,700	8.20	40000	3.6	27200	2.40	1400
	E*1P62D+H4TXV02	EFV20DC	15.00	12.50	41000	30,700	8.20	40000	3.6	28000	2.40	1400
	E*1P62D+H4TXV02	A80UH2V135D20*	15.00	12.50	41000	30,700	8.50	40000	3.6	28000	2.40	1400
	E*1P62D+H4TXV02	A95UH2V135D20S	15.00	12.50	41000	30,700	8.50	40000	3.6	28000	2.40	1400
	E*1P62D+H4TXV02	A97USMV135D20*	15.00	12.50	41000	30,700	8.50	40000	3.6	28000	2.40	1400
	E*1P62D+H4TXV02	A80UH1E135D20*	15.00	12.50	41000	30,700	8.20	40000	3.6	28000	2.40	1400
	E*1P62D+H4TXV02	A95UH1E135D20S	15.00	12.50	41000	30,700	8.50	40000	3.6	28000	2.40	1400
	E*1P62D+H4TXV02	A80US2V135D20*	15.00	12.50	41000	30,700	8.50	40000	3.6	28000	2.40	1400
	E*1P62D+H4TXV02	A96US2V135D20S	15.00	12.50	41000	30,700	8.50	40000	3.6	28000	2.40	1400
<b>4SHP14L*148P-7</b>	BCE3M48C****P+H4TXV02		14.00	12.00	47000	34,600	8.20	46000	3.4	29600	2.50	1600
	BCE3M48E****X		15.00	12.50	47000	34,600	8.50	46000	3.4	29600	2.50	1600
	BCS2M48S00NA1P+H4TXV02		15.00	12.50	47000	34,600	8.50	45500	3.4	29600	2.50	1600
	BCS2M48V00NA1P+H4TXV02		15.00	12.50	47000	34,600	8.50	45500	3.4	29600	2.50	1600
	BCS2M60S00NA1P+H4TXV02		15.00	12.50	47000	34,600	8.50	45500	3.4	29600	2.50	1600
	BCS2M60V00NA1P+H4TXV02		15.00	12.50	47000	34,600	8.50	45500	3.4	29600	2.50	1600
	E*1P49C+H4TXV02	A95DF1E110C20S	14.50	12.50	47000	34,600	8.20	46000	3.4	29600	2.50	1600
	E*1P49C+H4TXV02	A95UH2V110C16S	14.50	12.50	47000	34,600	8.20	46000	3.4	29600	2.50	1600
	E*1P49C+H4TXV02	A80UH2V090C20*	14.50	12.50	47000	34,600	8.20	46000	3.4	29600	2.50	1600
	E*1P49C+H4TXV02	A80DF2V110C20*	15.00	12.50	47000	34,600	8.50	46000	3.4	29600	2.50	1600
	E*1P49C+H4TXV02	A80UH2V110C20*	14.50	12.50	47000	34,600	8.20	46000	3.4	29600	2.50	1600
	E*1P49C+H4TXV02	A97USMV090C16*	14.50	12.50	47000	34,600	8.20	46000	3.4	29600	2.50	1600
	E*1P49C+H4TXV02	L83B*1V112/125F20	14.00	12.00	47000	34,600	8.20	46000	3.4	29600	2.50	1600
	E*1P49C+H4TXV02	A80US2V090C20*	14.50	12.50	47000	34,600	8.20	46000	3.4	29600	2.50	1600
	E*1P49C+H4TXV02	A80US2V110C20*	14.50	12.50	47000	34,600	8.20	46000	3.4	29600	2.50	1600
	E*1P49C+H4TXV02	A80DS2V110C20*	15.00	12.50	47000	34,600	8.50	46000	3.4	29600	2.50	1600
	E*1P49C+H4TXV02	A97USMV090C20*	14.50	12.50	47000	34,600	8.20	46000	3.4	29600	2.50	1600
	E*1P49C+H4TXV02	A97USMV110C20*	14.50	12.50	47000	34,600	8.20	46000	3.4	29600	2.50	1600
	E*1P49C+H4TXV02	A80DF1E110C20	14.50	12.50	47000	34,600	8.20	46000	3.4	29600	2.50	1600
	E*1P49C+H4TXV02	A95UH2E090C16S	14.50	12.50	47000	34,600	8.20	46000	3.4	29600	2.50	1600
	E*1P49C+H4TXV02	L85B*1V104/118F20	14.00	12.00	47000	34,600	8.20	46000	3.4	29600	2.50	1600
	E*1P49C+H4TXV02	A96US2V110C16S	14.50	12.50	47000	34,600	8.20	46000	3.4	29600	2.50	1600
	E*1P62D+H4TXV02	A80UH2V135D20*	14.50	12.50	47000	34,600	8.20	46000	3.4	29600	2.50	1600
	E*1P62D+H4TXV02	A95UH2V135D20S	14.50	12.50	47000	34,600	8.20	46000	3.4	29600	2.50	1600
	E*1P62D+H4TXV02	A97USMV135D20*	14.50	12.50	47000	34,600	8.20	46000	3.4	29600	2.50	1600
	E*1P62D+H4TXV02	A80UH1E135D20*	14.50	12.50	47000	34,600	8.20	46000	3.4	29600	2.50	1600
	E*1P62D+H4TXV02	A80US2V135D20*	14.50	12.50	47000	34,600	8.20	46000	3.4	29600	2.50	1600
	E*1P62D+H4TXV02	A96US2V135D20S	14.50	12.50	47000	34,600	8.20	46000	3.4	29600	2.50	1600

Note:

1. Certified in accordance with Unitary Air Conditioner Certification Program, which is based on AHRI Standard 210/240
2. Required to achieve AHRI rating. If NA (Not Applicable) is in the piston column, then TXV is required.
3. A blower time delay relay is required to achieve AHRI rating. This feature is standard on all Allied Air Enterprises furnace and AH products.

**COOLING PERFORMANCE WITH AIR HANDLERS AND FURNACES**

Outdoor Model	Indoor Model	Furnace	Cooling				Heating				CFM	
	Evap. Coil <sup>3</sup>		SEER	EER	AHRI Rated Capacity <sup>1</sup> BTUH	Sensible Capacity BTUH	HSPF	47°		17°		
								Btuh	COP	Btuh		COP
<b>4SHP14L*160P-7</b>	BCE3M60C****P+H4TXV03		14.00	12.00	57000	42,300	8.20	55000	3.4	36000	2.50	1900
	BCE3M60E****X		15.00	12.50	57000	42,300	8.50	55000	3.4	36000	2.50	1900
	BCS2M60S00NA1P+H4TXV03		15.00	12.50	57000	42,300	8.50	55000	3.4	36000	2.50	1800
	BCS2M60V00NA1P+H4TXV03		15.00	12.50	57000	42,300	8.50	55000	3.4	36000	2.50	1800
	E*1P62C+H4TXV03+TDR		14.00	12.00	57000	42,300	8.20	55000	3.4	36000	2.50	1900
	E*1P62D+H4TXV03+TDR		14.00	12.00	57000	42,300	8.20	55000	3.4	36000	2.50	1900

**HEATING PERFORMANCE EXTENDED RATINGS**

Outdoor Model	Indoor Model	Outdoor Temp. DB/WB deg. F									
		0/0		17/15		35/33		47/43		62/56	
		Btuh	KW	Btuh	KW	Btuh	KW	Btuh	KW	Btuh	KW
4SHP14L*118P-7	BCE3M18C	8,900	1.35	11,400	1.43	14,000	1.45	18,000	1.50	21,500	1.55
4SHP14L*124P-7	BCE3M24C	5,800	1.50	14,000	1.80	18,700	1.80	22,000	1.90	26,900	2.00
4SHP14L*130P-7	BCE3M30C	7,800	1.75	17,000	2.00	22,600	2.20	26,200	2.25	31,600	2.35
4SHP14L*136P-7	BCE3M36C	9,700	2.20	21,600	2.50	29,700	2.80	34,600	2.90	41,900	3.00
4SHP14L*142P-7	BCE3M42C	12,700	3.15	28,800	3.50	36,000	3.40	42,000	3.50	51,000	3.65
4SHP14L*148P-7	BCE3M48C	14,100	2.85	29,600	3.50	40,300	3.80	46,500	4.00	55,800	4.30
4SHP14L*160P-7	BCE3M60C	18,000	3.35	36,000	4.20	48,000	4.75	55,000	5.00	65,500	5.40

Note:  
 All ratings are at indoor temperature of 70 oF  
 Extended data shown is actual for models listed and typical for all AHRI matches.

**ACCESSORIES**

Description	Where Used	Kit Number
Crankcase Heater	18, 24, 30, 36	93M04
	42, 48, 60	93M05 (factory Installed)
Compressor Low Ambient Kit	18, 24, 30, 36, 42, 48, 60	45F08
Sound Blanket	18, 24, 30,36	14W00 (factory Installed)
	42, 48, 60	14W01 (factory Installed)
Short Cycle Protector	18, 24, 30, 36, 42, 48, 60	control board feature
Freezestat	3/8 tubing	93G35
	5/8 tubing	50A93
Time Delay Relay	18, 24, 30, 36, 42, 48, 60	control board feature
Loss of Charge Kit	18, 24, 30, 36, 42, 48, 60	84M23 (factory Installed)
Hard start kit	18	10J42
	24, 30, 36, 42, 48, 60	88M91
Fossil Fuel	All Models	AFOSL500
TXV	18, 24, 30	H4TXV01
	36, 42, 48	H4TXV02
	60	H4TXV03

Note:  
 1. Certified in accordance with Unitary Air Conditioner Certification Program, which is based on AHRI Standard 210/240  
 2. Required to achieve AHRI rating. If NA (Not Applicable) is in the piston column, then TXV is required.  
 3. A blower time delay relay is required to achieve AHRI rating. This feature is standard on all Allied Air Enterprises furnace and AH products.

**COOLING PERFORMANCE EXTENDED RATINGS**

Outdoor Model	Indoor Model	Indoor Temp DB/WB °F	Outdoor Temperature - DB °F														
			65°			82°			95°			105°			115°		
			Btuh	S/T	kW	Btuh	S/T	kW	Btuh	S/T	kW	Btuh	S/T	kW	Btuh	S/T	kW
4SHP14L*118P-7	BCE3M3BC	85/72	22,261	0.67	1.12	20,875	0.68	1.33	19,815	0.68	1.49	18,509	0.69	1.67	17,203	0.70	1.84
		80/67	20,970	0.71	1.13	19,887	0.72	1.36	19,059	0.73	1.53	17,368	0.76	1.62	15,677	0.78	1.85
		75/63	19,437	0.74	1.13	17,871	0.75	1.35	16,673	0.76	1.51	15,622	0.79	1.68	14,570	0.82	1.85
		75/57	17,011	1.00	1.15	15,956	1.00	1.36	15,150	1.00	1.52	14,333	1.00	1.68	13,515	1.00	1.85
4SHP14L*124P-7	BCE3M24C	85/72	30,200	0.61	1.48	27,700	0.64	1.75	25,700	0.66	1.95	24,200	0.68	2.20	22,700	0.69	2.44
		80/67	27,600	0.69	1.47	25,200	0.71	1.74	23,400	0.73	1.95	22,100	0.75	2.19	20,700	0.77	2.42
		75/63	25,100	0.72	1.47	23,300	0.74	1.74	21,800	0.76	1.95	20,500	0.78	2.19	19,100	0.80	2.43
		75/57	24,000	1.00	1.44	22,400	1.00	1.71	20,800	1.00	1.91	19,700	1.00	2.15	18,400	1.00	2.37
4SHP14L*130P-7	BCE3M30C	85/72	35,800	0.62	1.88	33,600	0.64	2.19	31,900	0.66	2.43	30,200	0.68	2.72	28,400	0.70	3.00
		80/67	33,500	0.69	1.86	31,000	0.72	2.18	29,000	0.74	2.42	27,600	0.76	2.70	26,200	0.78	2.99
		75/63	31,300	0.72	1.84	29,000	0.75	2.17	27,300	0.77	2.42	25,700	0.79	2.70	24,100	0.81	2.98
		75/57	29,100	1.00	1.82	27,600	1.00	2.14	25,800	1.00	2.37	24,600	1.00	2.65	23,300	1.00	2.93
4SHP14L*136P-7	BCE3M36C	85/72	39,700	0.61	2.21	38,100	0.64	2.59	36,900	0.67	2.89	34,600	0.70	3.21	32,400	0.73	3.54
		80/67	37,800	0.69	2.20	36,000	0.72	2.59	34,600	0.75	2.88	31,900	0.79	3.21	29,300	0.83	3.53
		75/63	36,100	0.73	2.20	33,300	0.77	2.58	31,100	0.80	2.87	29,000	0.83	3.19	26,800	0.85	3.51
		75/57	32,900	1.00	2.16	32,000	1.00	2.54	30,800	1.00	2.82	28,400	1.00	3.15	26,100	1.00	3.46
4SHP14L*142P-7	BCE3M42C	85/72	50,600	0.60	2.66	47,800	0.63	3.14	45,700	0.65	3.51	42,800	0.67	3.92	39,900	0.69	4.33
		80/67	48,200	0.68	2.66	44,700	0.71	3.13	42,000	0.73	3.50	39,500	0.75	3.91	37,000	0.77	4.33
		75/63	44,200	0.72	2.64	41,300	0.74	3.12	39,200	0.75	3.49	36,600	0.77	3.89	34,000	0.79	4.30
		75/57	41,900	1.00	2.61	39,800	1.00	3.07	37,400	1.00	3.43	35,200	1.00	3.83	32,900	1.00	4.24
4SHP14L*148P-7	BCE3M48C	85/72	51,900	0.62	2.95	51,400	0.64	3.55	51,000	0.65	4.00	48,400	0.68	4.47	45,800	0.70	4.93
		80/67	49,800	0.68	2.95	48,800	0.70	3.55	48,000	0.72	4.00	45,500	0.75	4.45	42,900	0.77	4.90
		75/63	47,900	0.71	2.95	45,600	0.74	3.53	43,800	0.77	3.98	40,800	0.82	4.43	37,900	0.86	4.88
		75/57	43,300	1.00	2.89	43,400	1.00	3.48	42,700	1.00	3.92	40,500	1.00	4.36	38,200	1.00	4.80
4SHP14L*160P-7	BCE3M60C	85/72	72,000	0.62	3.68	66,300	0.65	4.34	62,000	0.67	4.85	58,000	0.69	5.47	54,000	0.71	6.09
		80/67	65,800	0.68	3.64	61,400	0.71	4.32	58,000	0.73	4.83	54,000	0.77	5.45	50,000	0.80	6.07
			60,800	0.71	3.60	56,200	0.74	4.29	52,700	0.76	4.81	49,400	0.78	5.43	46,100	0.80	6.04
		75/57	57,200	1.00	3.57	54,600	1.00	4.23	51,600	1.00	4.73	48,100	1.00	5.34	44,500	1.00	5.95

Note:  
 Extended data shown is actual for models listed and typical for all AHRI matches.



1-800-448-5872

All specifications and illustrations subject to change without notice and without incurring obligations.