

# INSTALLATION INSTRUCTIONS

## ⚠️ WARNING

Improper installation, adjustment, alteration, service or maintenance can cause property damage, personal injury or loss of life. Installation and service must be performed by a licensed professional HVAC installer or equivalent, service agency, or the gas supplier

## ⚠️ CAUTION

As with any mechanical equipment, contact with sharp sheet metal edges can result in personal injury. Take care while handling this equipment and wear gloves and protective clothing.

<b>ZG/ZC 092</b>	(7.5 Ton)
<b>ZG/ZC 102</b>	(8.5 Ton)
<b>ZG/ZC 120</b>	(10 Ton)
<b>ZG/ZC 150</b>	(12-1/2 Ton)

**GAS AND COOLING PACKAGED UNITS**  
 507256-03  
 10/2017  
 Supersedes 507256-02

### Table Of Contents

Dimensions .....	Page 2
Parts Arrangements .....	Page 3
Shipping and Packing List .....	Page 4
General .....	Page 4
Safety .....	Page 4
Unit Support .....	Page 5
Horizontal Air Discharge .....	Page 5
Duct Connection .....	Page 6
Rigging Unit For Lifting .....	Page 6

Condensate Drains .....	Page 7
Connect Gas Piping .....	Page 7
Pressure Test Gas Piping .....	Page 8
High Altitude Derate .....	Page 8
Electrical Connections .....	Page 9
Unit Power-Up .....	Page 9
Blower Operation and Adjustments .....	Page 10
Cooling Start-Up .....	Page 18
Gas Heat Start-Up .....	Page 26
Heating Operation and Adjustments .....	Page 27
Electric Heat Start-Up .....	Page 27
Service .....	Page 28

**RETAIN THESE INSTRUCTIONS FOR FUTURE REFERENCE**

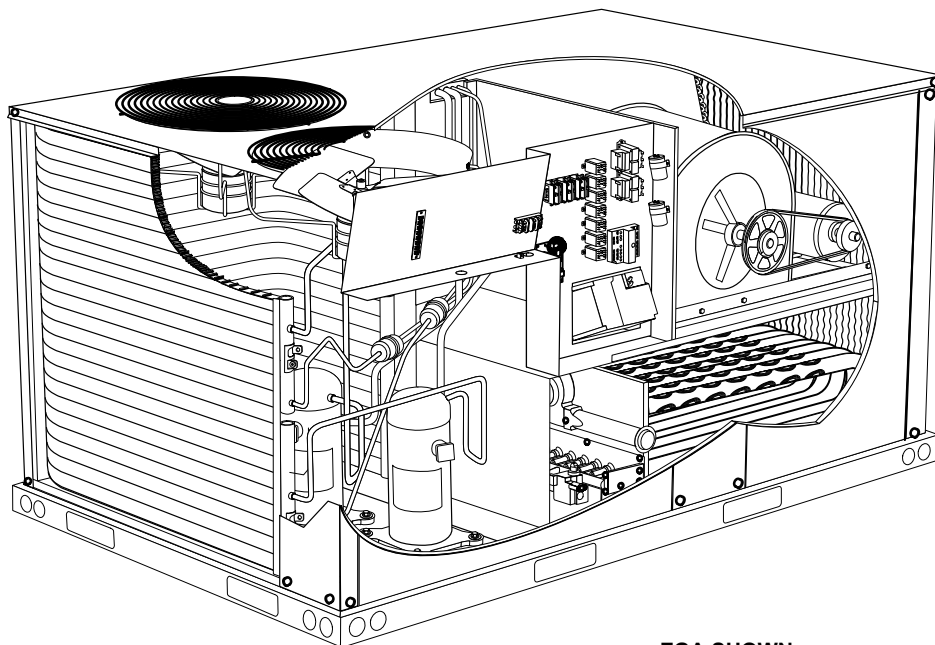

ZGA SHOWN

**ZG/ZC 092, 102, 120, & 150 DIMENSIONS - Gas heat section shown**

**BOTTOM POWER ENTRY**

Holes required for Optional Bottom Power Entry Kit

	Threaded Conduit Fittings (Provided in Kit)	Wire Use	Hole Diameter Required in Unit Base (Max.)
A	1/2	ACC.	7/8 (23)
B	1/2	24V	7/8 (23)
C	1-1/4	POWER	1-3/4 (44)
D	3/4	AUX	1-3/4 (44)

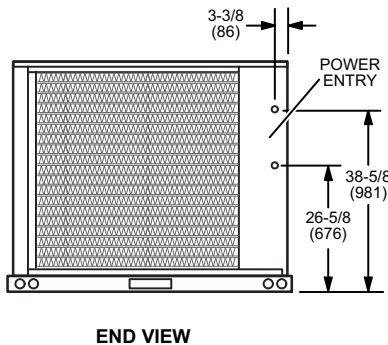
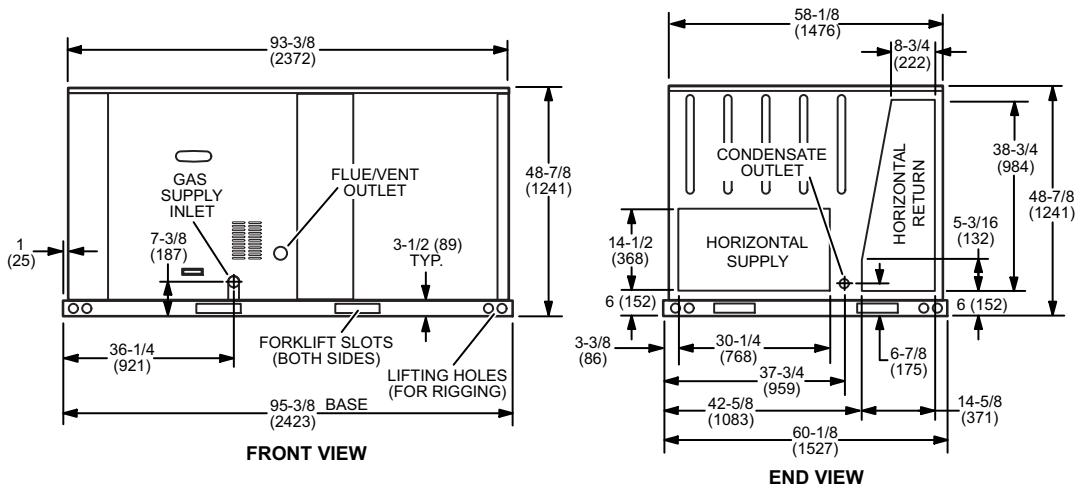
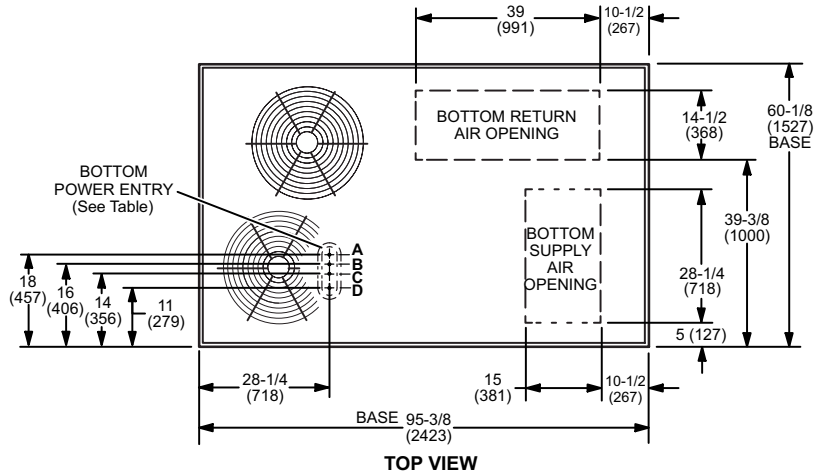

## ZG 092, 102, 120, & 150 PARTS ARRANGEMENT

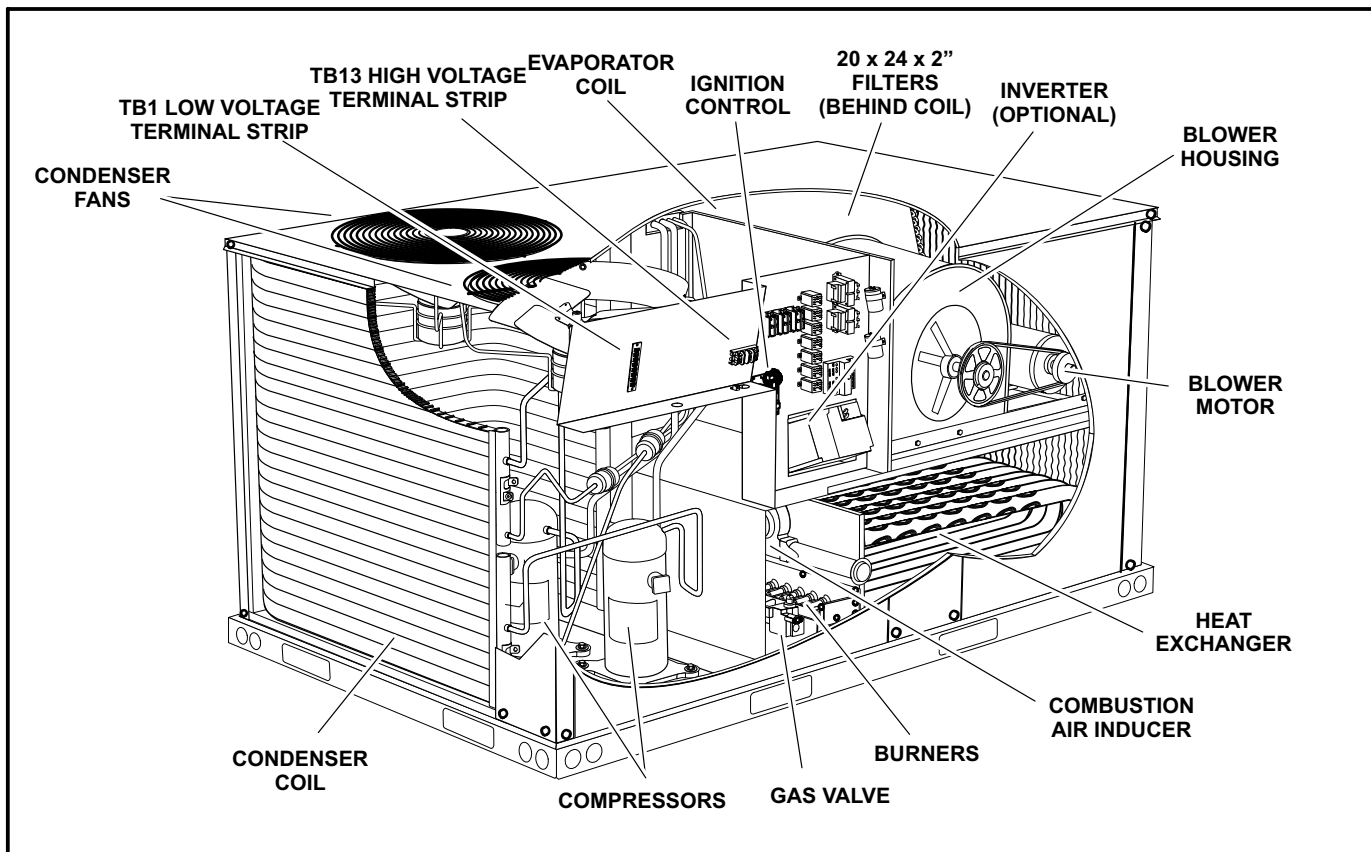

## ZC 092, 102, 120, & 150 PARTS ARRANGEMENT

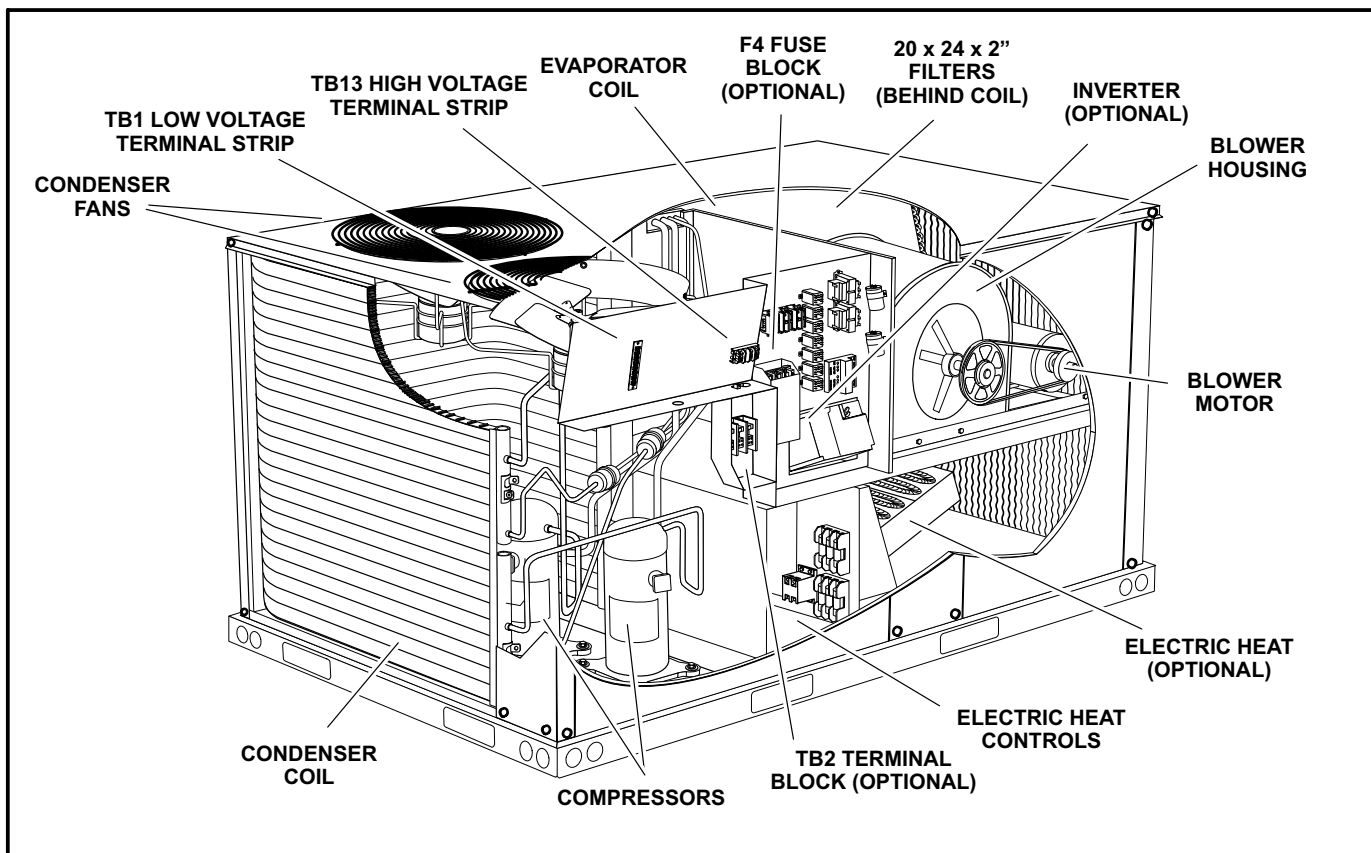

## Shipping and Packing List

### Package 1 of 1 contains:

1- Assembled unit

Check unit for shipping damage. Receiving party should contact last carrier immediately if shipping damage is found.

## General

These instructions are intended as a general guide and do not supersede local codes in any way. Authorities having jurisdiction should be consulted before installation.

The ZG units are available in three heating inputs. The ZC cooling packaged rooftop unit is the same basic design as the ZG unit except for the heating section. Optional electric heat is available for ZC units. ZG and ZC units have identical refrigerant circuits with respective 7-1/2, 8-1/2, 10, and 12-1/2 ton cooling capacities.

Units are available with an optional supply air inverter. During cooling, the blower will operate at lower speeds when demand is low and increase to higher speeds when demand is high. During a blower only demand, the blower will operate at low speed. During a heating demand, the blower will operate at high speed.

Availability of units and options varies by brand.

## Safety

See figure 1 for unit clearances.

Use of this unit as a construction heater or air conditioner is not recommended during any phase of construction. Very low return air temperatures, harmful vapors and operation of the unit with clogged or misplaced filters will damage the unit.

## ⚠ IMPORTANT

The Clean Air Act of 1990 bans the intentional venting of refrigerant (CFC's and HCFC's) as of July 1, 1992. Approved methods of recovery, recycling or reclaiming must be followed. Fines and/or incarceration may be levied for non-compliance.

## ⚠ WARNING



Electric shock hazard and danger of explosion. Can cause injury, death or product or property damage. Turn off gas and electrical power to unit before performing any maintenance or servicing operations on the unit. Follow lighting instructions attached to unit when putting unit back into operation and after service or maintenance.

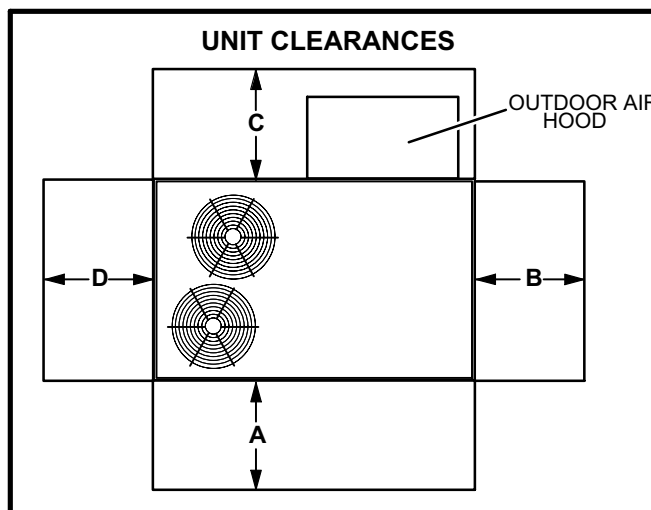

FIGURE 1

<sup>1</sup> Unit Clearance	A in.(mm)	B in.(mm)	C in.(mm)	D in.(mm)	Top Clearance
Service Clearance	36 (914)	36 (914)	60 (1524)	36 (914)	Unob- structed
Clearance to Combustibles*	36 (914)	1 (25)	1 (25)	1 (25)	Unob- structed
Minimum Operation Clearance	36 (914)	36 (914)	60 (1524)	36 (914)	Unob- structed

Note - Entire perimeter of unit base requires support when elevated above mounting surface.

<sup>1</sup> **Service Clearance** - Required for removal of serviceable parts.

**Clearance to Combustibles\*** - Required clearance to combustible material.

**Minimum Operation Clearance** - Required clearance for proper unit operation.

\*Gas units.

## ⚠ NOTICE

### Roof Damage!

This system contains both refrigerant and oil. Some rubber roofing material may absorb oil, causing the rubber to swell. Bubbles in the rubber roofing material can cause leaks. Protect the roof surface to avoid exposure to refrigerant and oil during service and installation. Failure to follow this notice could result in damage to roof surface.

If this unit has been used for heating or cooling of buildings or structures under construction, the following conditions must be met or the warranty will be void:

- A room thermostat must control the unit. The use of fixed jumpers that will provide continuous heating or cooling is not allowed.
- A pre-filter must be installed at the entry to the return air duct.
- The return air duct must be provided and sealed to the unit.
- Return air temperature range between 55°F (13°C) and 80°F (27°C) must be maintained.
- Air filters must be replaced and pre-filters must be removed upon construction completion.
- The input rate and temperature rise must be set per the unit rating plate.

- The heat exchanger, components, duct system, air filters and evaporator coil must be thoroughly cleaned following final construction clean-up.
- The unit operating conditions (including airflow, cooling operation, ignition, input rate, temperature rise and venting) must be verified according to these installation instructions.

## Unit Support

In downflow discharge installations, install the unit on a non-combustible surface only. Unit may be installed on combustible surfaces when used in horizontal discharge applications or in downflow discharge applications when installed on an Z1CURB roof mounting frame.

*NOTE - Securely fasten roof frame to roof per local codes.*

## ⚠ CAUTION

**To reduce the likelihood of supply / return air bypass and promote a proper seal with the RTU, duct work / duct drops / diffuser assemblies must be supported independently to the building structure.**

### A-Downflow Discharge Application

#### Roof Mounting with Z1CURB

- 1- The Z1CURB roof mounting frame must be installed, flashed and sealed in accordance with the instructions provided with the frame.
- 2- The Z1CURB roof mounting frame should be square and level to 1/16" per linear foot (5mm per linear meter) in any direction.
- 3- Duct must be attached to the roof mounting frame and not to the unit; supply and return plenums must be installed before setting the unit.

#### Installer's Roof Mounting Frame

Many types of roof frames can be used to install the unit depending upon different roof structures. Items to keep in mind when using the building frame or supports are:

- 1- The base is fully enclosed and insulated, so an enclosed frame is not required.
- 2- The frames or supports must be constructed with non-combustible materials and should be square and level to 1/16" per linear foot (5mm per linear meter) in any direction.
- 3- Frame or supports must be high enough to prevent any form of moisture from entering unit. Recommended minimum frame height is 14" (356mm).

4- Duct must be attached to the roof mounting frame and not to the unit. Supply and return plenums must be installed before setting the unit.

5- Units require support along all four sides of unit base. Supports must be constructed of steel or suitably treated wood materials.

*NOTE-When installing a unit on a combustible surface for downflow discharge applications, an Z1CURB roof mounting frame is required.*

### B-Horizontal Discharge Applications

- 1- Specified installation clearances must be maintained when installing units. Refer to figure 1.
- 2- Top of support slab should be approximately 4" (102mm) above the finished grade and located so no run-off water from higher ground can collect around the unit.
- 3- Units require support along all four sides of unit base. Supports must be constructed of steel or suitably treated wood materials.

## Horizontal Air Discharge

Unit is shipped with panels covering the horizontal supply and return air openings. Remove horizontal covers and place over downflow opening for horizontal air discharge. See figure 2. Secure in place with sheet metal screws.

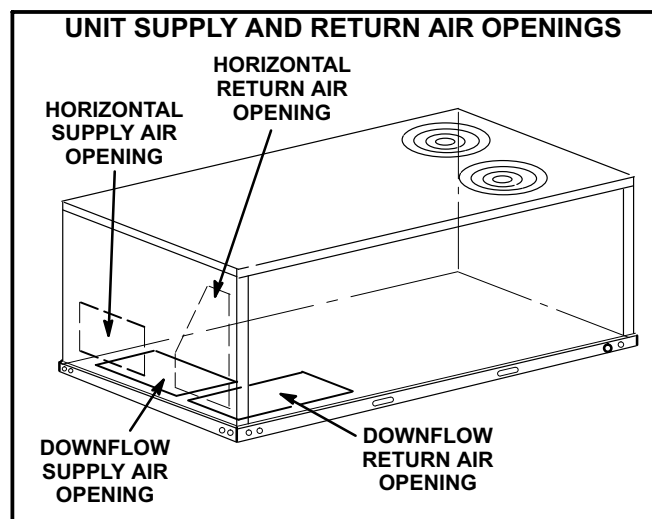

**FIGURE 2**

*Units Equipped With An Optional Horizontal Economizer*

- 1- Install the horizontal supply and return air covers over the down flow air openings as described above.
- 2- Install supply and return air ducts on the horizontal supply and return air openings on the unit. See figure 3.
- 3- Horizontal economizer and supply and return air duct must be field-supported.

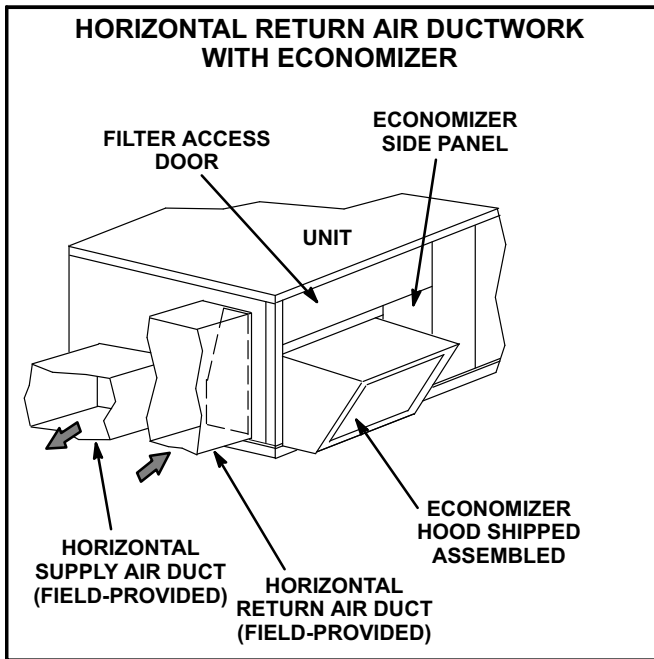

**FIGURE 3**

**Duct Connection**

All exterior ducts, joints and openings in roof or building walls must be insulated and weather-proofed with flashing and sealing compounds in accordance with applicable codes. Any duct passing through an unconditioned space must be insulated.

**CAUTION**

**In downflow applications, do not drill or punch holes in base of unit. Leaking in roof may occur if unit base is punctured.**

**Rigging Unit For Lifting**

Rig unit for lifting by attaching four cables to holes in unit base rail. See figure 4.

- 1- Detach wooden base protection before rigging.
- 2- Connect rigging to the unit base using both holes in each corner.
- 3- All panels must be in place for rigging.
- 4- Place field-provided H-style pick in place just above top edge of unit. Frame must be of adequate strength and length. (H-style pick prevents damage to unit.)
- 5- **All Units -** Partially lift unit and remove five (5) L-brackets which secure the protective base board. See figure 4.

**Important - Protective wooden base board must be removed before setting unit.**

- 6- **New roof curbs (89-3/8" in length) -**  
Remove the three alignment brackets shown in figure 5.
- 7- **Existing roof curbs (81-3/4" in length) -**  
Set unit on roof curb positioning alignment brackets as shown in figure 5.

**RIGGING - ALL UNITS**

Unit	*Weight	
	Lbs.	Kg.
ZGA092-150	1203	546
ZGB092-120		
ZGB150	1322	599
ZCA092-150	1168	530
ZCB092-120		
ZCB150	1287	583

**LIFTING POINT SHOULD BE DIRECTLY ABOVE CENTER OF GRAVITY**

**CAUTION - Do not walk on unit.**

**REMOVE FIVE (5) L-BRACKETS AND BASE PROTECTION BOARD**

**FIGURE 4**

**UNIT ALIGNMENT BRACKETS**

**NEW ROOF CURBS (89-3/8" IN LENGTH):**  
Remove all three brackets.

**EXISTING ROOF CURBS (81-3/4" LONG):**  
Set unit on roof curb positioning alignment brackets as shown.

**THREE (3) UNIT ALIGNMENT BRACKETS**

**ROOF CURB**

**FIGURE 5**

## Condensate Drains

Make drain connection to the 1" N.P.T. drain coupling provided on unit.

*Note - The drain pan is made with a glass reinforced engineered plastic capable of withstanding typical joint torque but can be damaged with excessive force. Tighten pipe nipple hand tight and turn an additional quarter turn.*

A trap must be installed between drain connection and an open vent for proper condensate removal. See figure 6. It is sometimes acceptable to drain condensate onto the roof or grade; however, a tee should be fitted to the trap to direct condensate downward. The condensate line must be vented. Check local codes concerning condensate disposal. Refer to page 2 for condensate drain location.

Units are shipped with the drain coupling facing the right side of the unit. The unit can be installed in either downflow or horizontal air discharge regardless of condensate drain location.

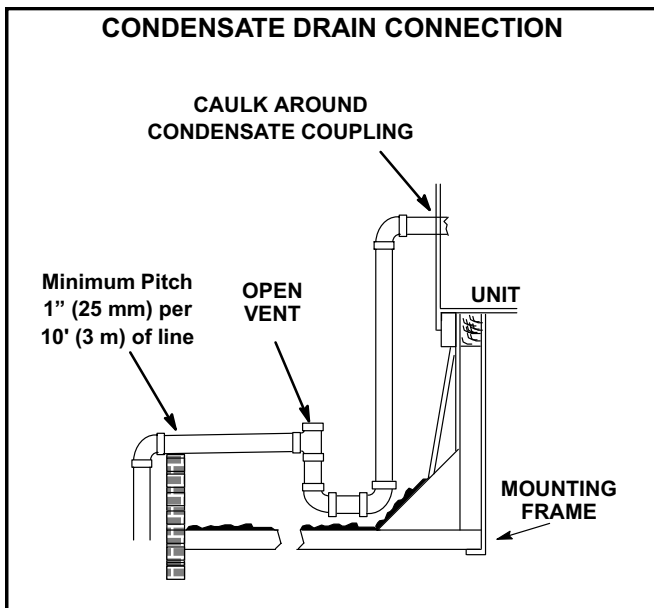

FIGURE 6

## Connect Gas Piping (Gas Units)

Before connecting field-provided piping, check with gas company or authorities having jurisdiction for local code requirements. When installing gas supply piping, length of run from gas meter must be considered in determining pipe size for 0.5" w.c. (.12kPa) maximum pressure drop. Do not use supply pipe smaller than unit gas connection. For natural gas units, operating pressure at the unit gas connection must be a minimum of 4.7" w.c. (1.19kPa) and a maximum of 10.5" (2.60kPa) w.c. For LP/propane gas units, operating pressure at the unit gas connection must be a minimum of 11" w.c. (2.74kPa) and a maximum of 13.0" w.c. (3.23kPa).

When making piping connections a drip leg should be installed on vertical pipe runs to serve as a trap for sediment or condensate. A 1/8" N.P.T. plugged tap is located on gas valve for test gauge connection. Refer to Heating Start-Up section for tap location. Install a ground joint union between the gas control manifold and the main manual shut-off valve. See figure 7 for gas supply piping entering outside the unit. Figure 8 shows bottom gas entry piping through the curb.

Compounds used on threaded joints of gas piping shall be resistant to the action of liquified petroleum gases.

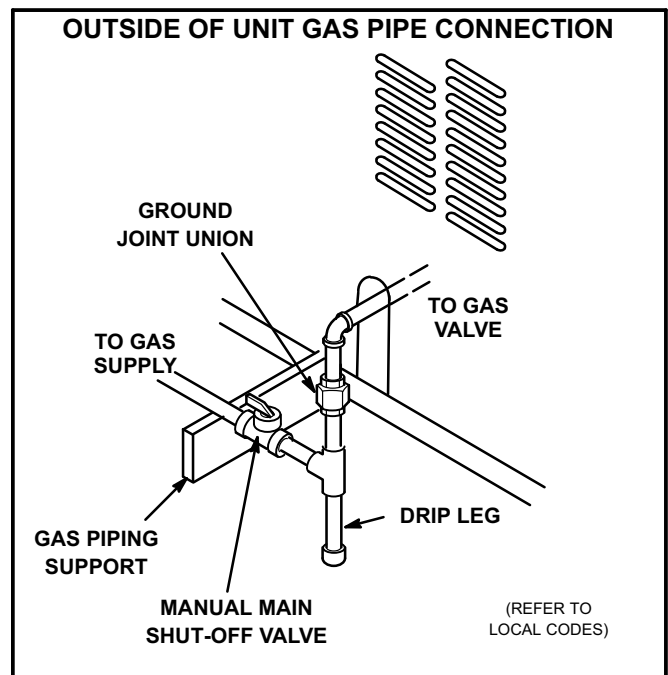

FIGURE 7

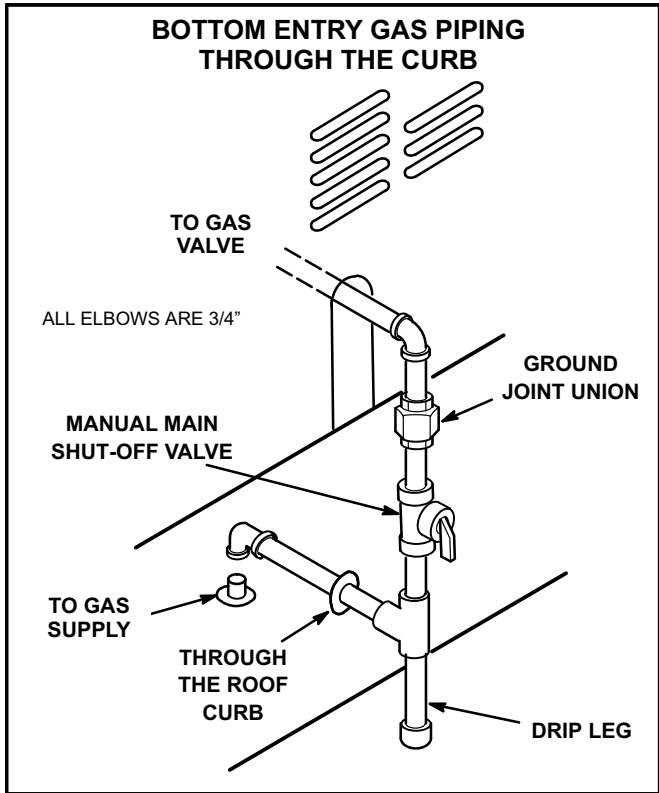

FIGURE 8

**Pressure Test Gas Piping (Gas Units)**

When pressure testing gas lines, the gas valve must be disconnected and isolated. Gas valves can be damaged if subjected to more than 0.5 psig (3.48kPa). See figure 9.

*NOTE-Codes may require that manual main shut-off valve and union (furnished by installer) be installed in gas line external to unit. Union must be of the ground joint type.*

After all connections have been made, check all piping connections for gas leaks. Also check existing unit gas connections up to the gas valve; loosening may occur during installation. Use a leak detection solution or other preferred means. Do not use matches candles or other sources of ignition to check for gas leaks.

**CAUTION**

Some soaps used for leak detection are corrosive to certain metals. Carefully rinse piping thoroughly after leak test has been completed. Do not use matches, candles, flame or othe sources of ignition to check for gas leaks.

**WARNING**



Danger of explosion. Can cause injury or product or property damage. Do not use matches, candles, flame or other sources of ignition to check for leaks.

*NOTE-In case emergency shut down is required, turn off the main manual shut-off valve and disconnect main power to unit. These devices should be properly labeled by the installer.*

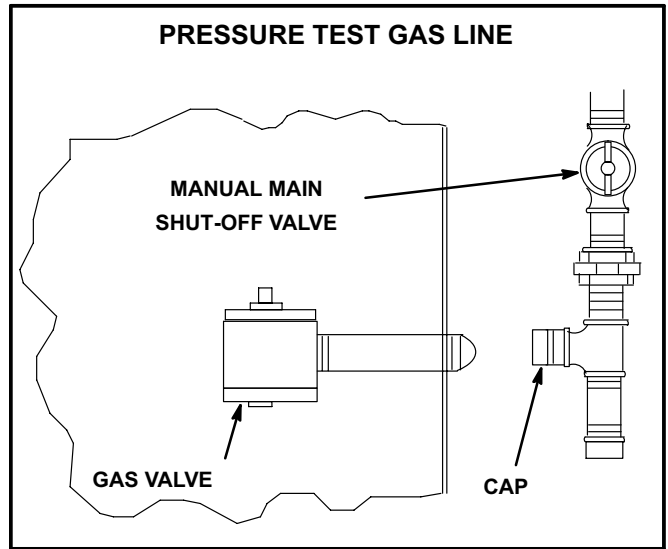

FIGURE 9

**High Altitude Derate**

Locate the high altitude conversion sticker in the unit literature bag. Fill out the conversion sticker and affix next to the unit nameplate.

Refer to table 1 for high altitude adjustments.

**TABLE 1  
HIGH ALTITUDE DERATE**

Altitude Ft.*	Gas Manifold Pressure
2000-4500	See Unit Nameplate
4500 And Above	Derate 2% / 1000 Ft. Above Sea Level

\*Units installed at 0-2000 feet do not need to be modified.

*NOTE - This is the only permissible derate for these units.*



## Electrical Connections

### POWER SUPPLY

Do not apply power or close disconnect switch until installation is complete. Refer to start-up directions. Refer closely to unit wiring diagram.

Refer to unit nameplate for minimum circuit ampacity and maximum fuse size.

- 1- 230/460/575 volt units are factory wired. **For 208V supply**, disconnect the pink wire (230V) at all control power transformer(s). Reconnect the pink wire (208V). Tape the exposed end of the 230V pink wire.
- 2- Route power through the bottom power entry area and connect to L1, L2, and L3 on the bottom of TB13 in control box. Route power to S48 disconnect switch when the option is factory-installed. See unit wiring diagram.

### CONTROL WIRING

#### A-Thermostat Location

Room thermostat mounts vertically on a standard 2" X 4" handy box or on any non-conductive flat surface.

Locate thermostat approximately 5 feet (1524mm) above the floor in an area with good air circulation at average temperature. Avoid locating the room thermostat where it might be affected by:

- drafts or dead spots behind doors and in corners
- hot or cold air from ducts
- radiant heat from sun or appliances
- concealed pipes and chimneys

#### B-Control Wiring

- 1- Route thermostat cable or wires from subbase to control box (refer to unit dimensions to locate bottom and side power entry).

**IMPORTANT** - Unless field thermostat wires are rated for maximum unit voltage, they must be routed away from line voltage wiring. Use wire ties located near the lower left corner of the controls hat section to secure thermostat cable.

Use 18 AWG wire for all applications using remotely installed electro-mechanical and electronic thermostats.

- 2- Install thermostat assembly in accordance with instructions provided with thermostat.

- 3- Connect thermostat wiring to TB1 terminal board on the left side of the controls area. Wire as shown in figure 10 for electro-mechanical and electronic thermostats. If using other temperature control devices or energy management systems see instructions and wiring diagram provided by manufacturer.

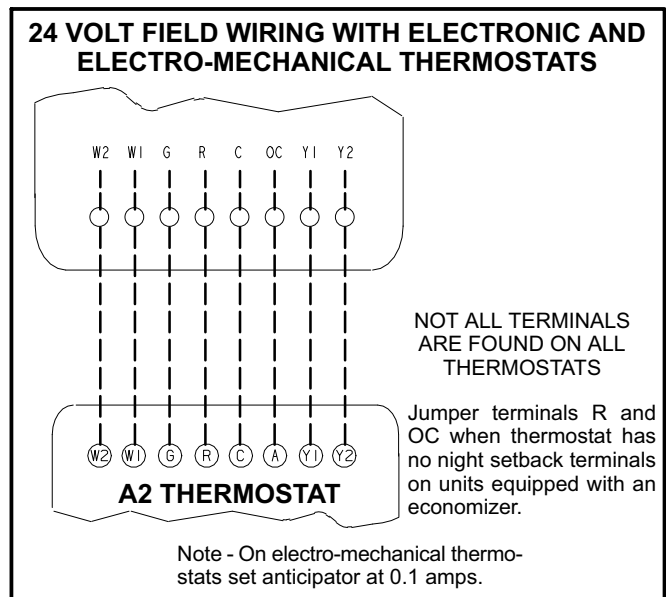

FIGURE 10

**IMPORTANT**-Terminal connections at the wall plate or subbase must be made securely. Loose control wire connections may allow unit to operate but not with proper response to room demand.

## Unit Power-Up

#### A-General

- 1- Make sure that unit is installed in accordance with the installation instructions and applicable codes.
- 2- Inspect all electrical wiring, both field- and factory-installed, for loose connections. Tighten as required.
- 3- Check to ensure that refrigerant lines do not rub against the cabinet or against other refrigerant lines.
- 4- Check voltage at main unit power connection. Voltage must be within range listed on nameplate. If not, consult power company and have voltage condition corrected before starting unit.
- 5- Make sure filters are in place before start-up.
- 6- Make sure there is no heating, cooling, or blower demand from thermostat. Apply power to unit.

## Blower Operation and Adjustments

### A-Three Scroll Compressor Voltage Phasing

Three phase scroll compressors must be phased sequentially to ensure correct compressor and blower rotation and operation. Compressor and blower are wired in phase at the factory. Power wires are color-coded as follows: line 1-red, line 2-yellow, line 3-blue.

- 1- Observe suction and discharge pressures and blower rotation on unit start-up.

If pressure differential is not observed or blower rotation is not correct:

- 2- Suction pressure must drop, discharge pressure must rise, and blower rotation must match rotation marking.
- 3- Disconnect all remote electrical power supplies.
- 4- Reverse any two field-installed wires connected to the line side of K3, TB2 or F4. Do not reverse wires at blower contactor or compressors.
- 5- Make sure the connections are tight.

Discharge and suction pressures should operate at their normal start-up ranges.

### B-Blower Operation

Initiate blower demand at thermostat according to instructions provided with thermostat. Unit will cycle on thermostat demand. The following steps apply to applications using a typical electro-mechanical thermostat.

- 1- Blower operation is manually set at the thermostat subbase fan switch. With fan switch in **ON** position, blowers will operate continuously.
- 2- With fan switch in **AUTO** position, the blowers will cycle with demand. Blowers and entire unit will be off when system switch is in **OFF** position.

### C-Blower Access

The blower assembly is secured to a sliding frame which allows the blower motor to be pulled out of the unit. See figure 11.

- 1- Loosen the reusable wire tie which secures the blower wiring to the blower motor mounting plate.
- 2- Remove and retain screws on either side of sliding frame. Pull frame toward outside of unit.
- 3- Slide frame back into original position when finished servicing. Reattach the blower wiring in the previous location on the blower motor base using the wire tie.
- 4- Replace retained screws on either side of the sliding frame.

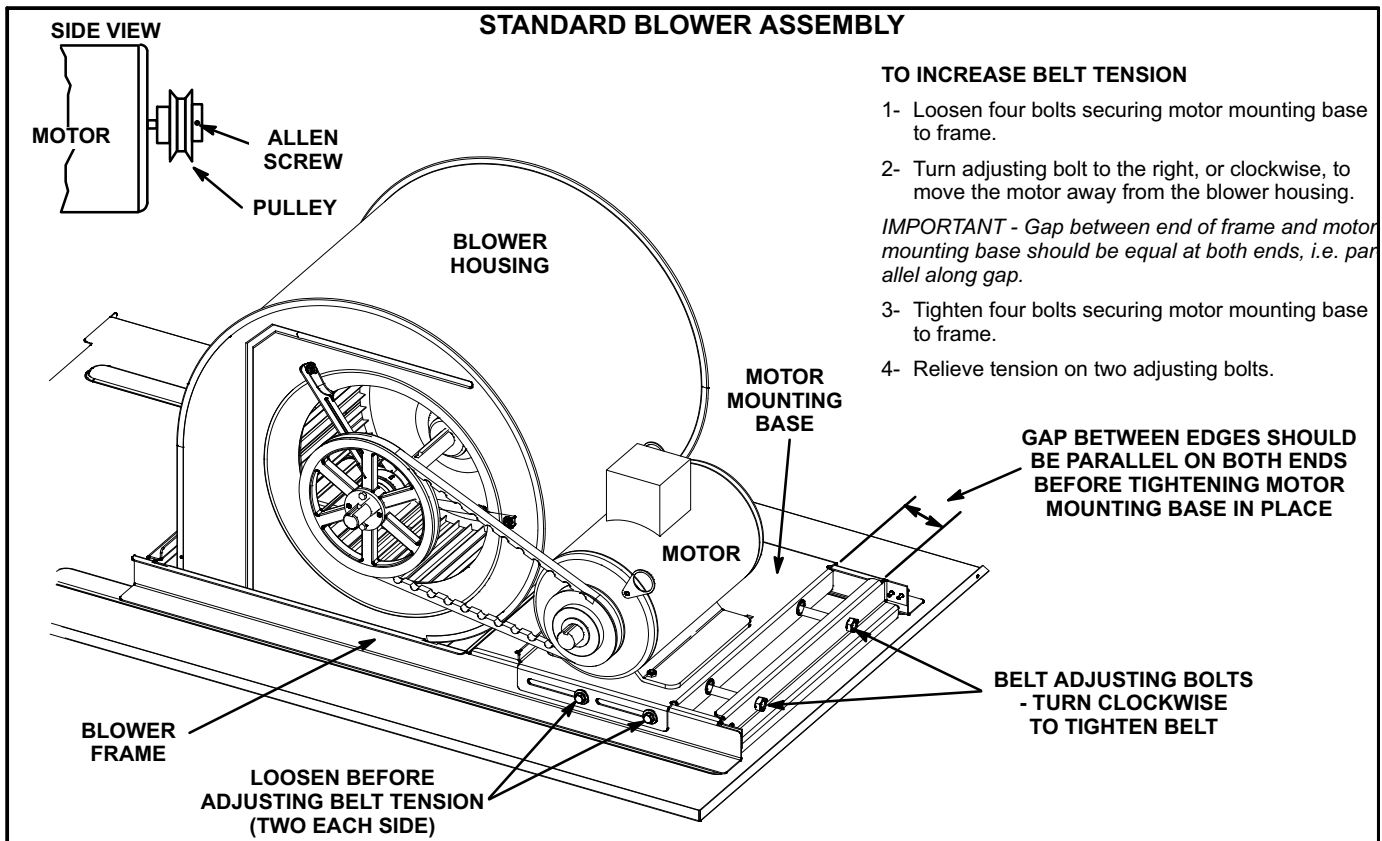

FIGURE 11

## D-Determining Unit CFM

- 1- The following measurements must be made with a dry indoor coil and air filters in place.

*Units **Not** Equipped With An Inverter -*  
Run blower without a cooling demand.

*Units Equipped With An Inverter -*  
Initiate high speed blower without a cooling demand. Disconnect high pressure switches S4 and S7. Run the blower with Y1 **and** Y2 demands.

- 2- Measure the indoor blower shaft RPM.
- 3- With all access panels in place, measure static pressure external to unit (from supply to return). Blower performance data is based on static pressure readings taken in locations shown in figure 12.

*Note - Static pressure readings can vary if not taken where shown.*

- 4- Referring to page 13, 14, or 15, use static pressure and RPM readings to determine unit CFM. Use pages 16 and 17 when installing units with any of the optional accessories listed.
- 5- The blower RPM can be adjusted at the motor pulley. Loosen Allen screw and turn adjustable pulley clockwise to increase CFM. Turn counterclockwise to decrease CFM. See figure 11. Do not exceed minimum and maximum number of pulley turns as shown in table 2.
- 6- *Units Equipped With An Inverter -*  
Reconnect high pressure switches S4 and S7.

**TABLE 2**  
**MINIMUM AND MAXIMUM PULLEY ADJUSTMENT**

Belt	Minimum Turns Open	Maximum Turns Open
A Section	0	5
B Section	1*	6

\*No minimum number of turns open when B belt is used on pulleys 6" O.D. or larger.

## E-Blower Belt Adjustment

Maximum life and wear can be obtained from belts only if proper pulley alignment and belt tension are maintained. Tension new belts after a 24-48 hour period of operation. This will allow belt to stretch and seat in the pulley grooves. Make sure blower and motor pulleys are aligned as shown in figure 13.

- 1- Loosen four bolts securing motor base to mounting frame. See figure 11.
- 2- *To increase belt tension -*  
Turn both adjusting bolts to the right, or clockwise, to move the motor outward and tighten the belt. This increases the distance between the blower motor and the blower housing.  
  
*To loosen belt tension -*  
Turn the adjusting bolts to the left, or counterclockwise to loosen belt tension.

**IMPORTANT -** Align top edges of blower motor base and mounting frame base parallel before tightening two bolts on the other side of base. Motor shaft and blower shaft must be parallel.

- 3- Tighten two bolts on each side of the motor mounting base. This secures the mounting base to the frame.

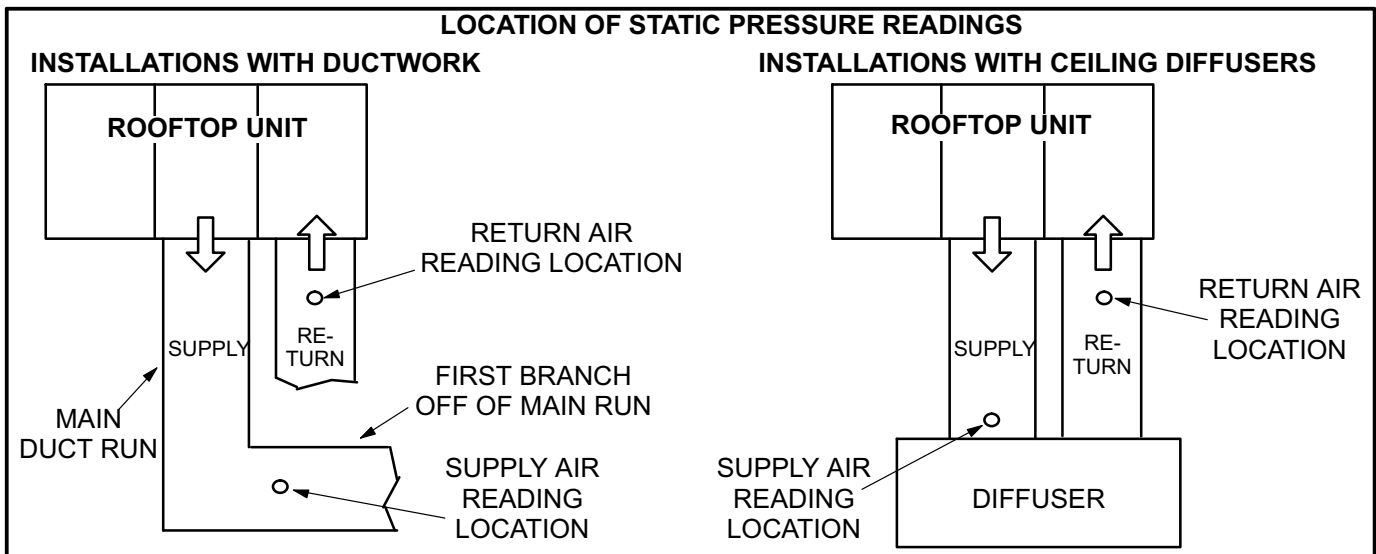

**FIGURE 12**

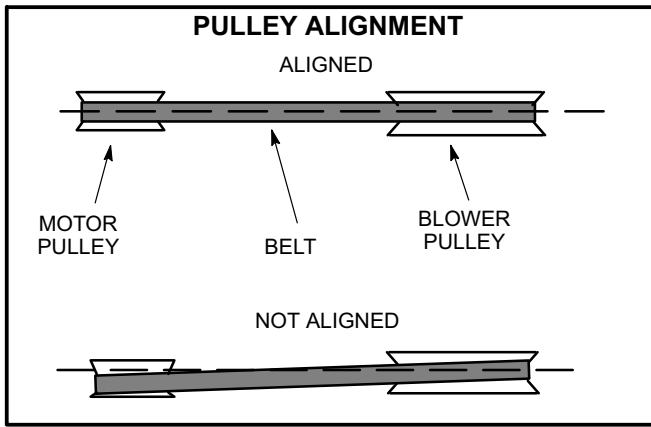

**FIGURE 13**

**F-Check Belt Tension**

Overtensioning belts shortens belt and bearing life. Check belt tension as follows:

- 1- Measure span length X. See figure 14.
- 2- Apply perpendicular force to center of span (X) with enough pressure to deflect belt 1/64" for every inch of span length or 1.5mm per 100mm of span length.

Example: Deflection distance of a 40" span would be 40/64" or 5/8".

Example: Deflection distance of a 400mm span would be 6mm.

- 3- Measure belt deflection force. For a new 2 and 3hp belt, the deflection force should be 5.0-7.0 lbs. (35-48kPa). For a new 5hp belt, the deflection force should be 7-10lbs. (48-69kPa).

A force below these values indicates an undertensioned belt. A force above these values indicates an overtensioned belt.

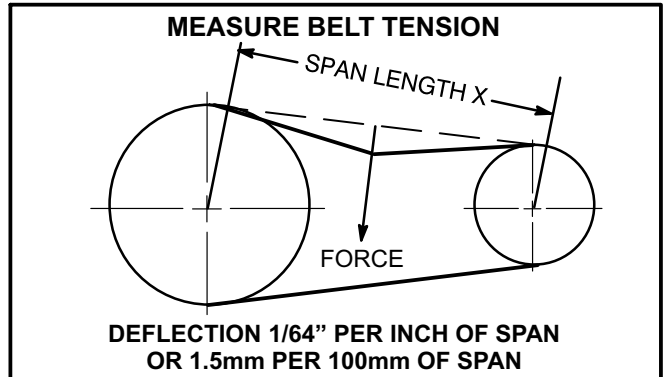

**FIGURE 14**

**F-Field-Furnished Blower Drives**

For field-furnished blower drives, use pages 13 through 17 to determine BHP and RPM required. Reference table 3 for drive component manufacturer's numbers.

## BLOWER DATA

### 092S STANDARD EFFICIENCY BELT DRIVE BLOWER – BASE UNIT

BLOWER TABLE INCLUDES RESISTANCE FOR BASE UNIT ONLY (NO HEAT SECTION) WITH DRY INDOOR COIL AND AIR FILTERS IN PLACE. FOR ALL UNITS ADD:

- 1 – Wet indoor coil air resistance of selected unit.
- 2 – Any factory installed options air resistance (heat section, economizer, etc.)
- 3 – Any field installed accessories air resistance (duct resistance, diffuser, etc.)

Then determine from blower table blower motor output required.

See page 17 for blower motors and drives.

See page 17 for wet coil and option/accessory air resistance data.

**MAXIMUM STATIC PRESSURE WITH GAS HEAT - 2.0 in. w.g.**

**MINIMUM AIR VOLUME REQUIRED FOR USE WITH OPTIONAL ELECTRIC HEAT (Maximum Static Pressure - 2.0 in. w.g.)**

**7.5kW, 15 kW, 22.5 kW - 2065 cfm**

**30 kW - 2250 cfm**

**45 kW - 2625 cfm**

Total Air Volume cfm	Total Static Pressure – in. w.g.																									
	0.2		0.4		0.6		0.8		1.0		1.2		1.4		1.6		1.8		2		2.2		2.4		2.6	
	RPM	BHP	RPM	BHP	RPM	BHP	RPM	BHP	RPM	BHP	RPM	BHP	RPM	BHP	RPM	BHP	RPM	BHP	RPM	BHP	RPM	BHP	RPM	BHP	RPM	BHP
1750	498	0.08	565	0.25	633	0.50	701	0.71	768	0.87	830	0.99	890	1.08	946	1.16	998	1.27	1049	1.41	1098	1.58	---	---	---	---
2000	512	0.12	578	0.37	645	0.60	713	0.81	780	0.97	842	1.10	901	1.19	955	1.28	1007	1.40	1057	1.56	1105	1.74	1153	1.94	1201	2.16
2250	527	0.24	592	0.49	659	0.72	727	0.92	793	1.08	855	1.21	913	1.32	966	1.42	1017	1.55	1066	1.72	1114	1.92	1162	2.13	1210	2.35
2500	543	0.37	608	0.61	675	0.84	743	1.04	809	1.21	869	1.35	926	1.45	978	1.57	1028	1.72	1076	1.90	1124	2.11	1171	2.33	1221	2.57
2750	560	0.51	625	0.75	693	0.98	761	1.18	826	1.35	885	1.49	939	1.60	990	1.73	1039	1.90	1087	2.10	1135	2.32	1183	2.55	1232	2.80
3000	579	0.66	645	0.90	713	1.13	781	1.34	844	1.51	901	1.65	954	1.77	1004	1.92	1052	2.11	1100	2.32	1147	2.56	1195	2.80	1245	3.05
3250	600	0.82	666	1.06	735	1.30	803	1.51	864	1.69	918	1.82	969	1.95	1018	2.12	1066	2.34	1113	2.57	1161	2.81	1209	3.06	1259	3.31
3500	622	0.98	690	1.24	760	1.49	826	1.70	883	1.87	936	2.01	985	2.16	1033	2.35	1081	2.59	1128	2.84	1176	3.09	1224	3.34	1275	3.60
3750	646	1.17	716	1.45	786	1.70	849	1.91	903	2.07	953	2.21	1002	2.38	1049	2.61	1097	2.87	1144	3.12	1192	3.38	1241	3.64	1292	3.91
4000	674	1.38	746	1.68	814	1.93	872	2.12	923	2.28	971	2.43	1019	2.64	1067	2.90	1114	3.17	1161	3.43	1209	3.69	1259	3.96	1311	4.24
4250	705	1.63	777	1.94	841	2.17	894	2.34	943	2.50	990	2.69	1038	2.93	1085	3.21	1132	3.49	1179	3.76	1228	4.03	1279	4.31	1332	4.60

## BLOWER DATA

### 102S STANDARD EFFICIENCY BELT DRIVE BLOWER – BASE UNIT

**BLOWER TABLE INCLUDES RESISTANCE FOR BASE UNIT ONLY (NO HEAT SECTION) WITH DRY INDOOR COIL AND AIR FILTERS IN PLACE. FOR ALL UNITS ADD:**

1 – Wet indoor coil air resistance of selected unit.

2 – Any factory installed options air resistance (heat section, economizer, etc.)

3 – Any field installed accessories air resistance (duct resistance, diffuser, etc.)

Then determine from blower table blower motor output required.

See page 17 for blower motors and drives.

See page 17 for wet coil and option/accessory air resistance data.

**MAXIMUM STATIC PRESSURE WITH GAS HEAT - 2.0 in. w.g.**

**MINIMUM AIR VOLUME REQUIRED FOR USE WITH OPTIONAL ELECTRIC HEAT (Maximum Static Pressure - 2.0 in. w.g.)**

**7.5kW, 15 kW, 22.5 kW - 2065 cfm**

**30 kW - 2250 cfm**

**45 kW - 2625 cfm**

Total Air Volume cfm	Total Static Pressure – in. w.g.																									
	0.2		0.4		0.6		0.8		1.0		1.2		1.4		1.6		1.8		2.0		2.2		2.4		2.6	
	RPM	BHP	RPM	BHP	RPM	BHP	RPM	BHP	RPM	BHP	RPM	BHP	RPM	BHP	RPM	BHP	RPM	BHP	RPM	BHP	RPM	BHP	RPM	BHP	RPM	BHP
1750	494	0.11	562	0.34	632	0.56	702	0.74	771	0.85	838	0.96	902	1.07	961	1.19	---	---	---	---	---	---	---	---	---	---
2000	514	0.26	581	0.49	650	0.70	719	0.87	786	0.98	852	1.09	915	1.20	972	1.32	1026	1.47	1076	1.65	---	---	---	---	---	---
2250	533	0.41	599	0.62	667	0.82	735	0.99	802	1.10	866	1.21	928	1.33	984	1.46	1037	1.63	1085	1.81	1132	2.01	1178	2.21	1226	2.43
2500	553	0.55	619	0.76	685	0.95	753	1.10	818	1.22	881	1.34	942	1.47	997	1.62	1048	1.80	1096	1.99	1142	2.20	1188	2.41	1237	2.64
2750	573	0.70	638	0.90	705	1.08	771	1.22	835	1.35	897	1.49	957	1.63	1011	1.80	1061	1.99	1108	2.19	1154	2.41	1200	2.63	1249	2.87
3000	594	0.85	659	1.05	725	1.22	791	1.36	853	1.50	915	1.65	973	1.81	1026	1.99	1075	2.20	1121	2.42	1167	2.64	1213	2.87	1262	3.12
3250	617	1.01	682	1.20	747	1.37	812	1.52	873	1.67	934	1.83	990	2.01	1042	2.21	1089	2.43	1135	2.66	1181	2.90	1228	3.13	1277	3.38
3500	640	1.17	706	1.36	771	1.53	834	1.70	895	1.86	954	2.03	1008	2.23	1058	2.46	1105	2.69	1150	2.93	1196	3.17	1243	3.41	1293	3.65
3750	665	1.34	731	1.54	796	1.72	857	1.89	917	2.07	975	2.26	1027	2.48	1076	2.72	1121	2.97	1166	3.22	1212	3.46	1261	3.71	1311	3.96
4000	692	1.54	758	1.75	822	1.93	882	2.11	940	2.30	996	2.51	1047	2.76	1094	3.02	1139	3.27	1184	3.52	1230	3.77	1280	4.03	1330	4.29
4250	722	1.76	787	1.97	849	2.15	908	2.35	965	2.56	1018	2.79	1067	3.06	1113	3.33	1157	3.59	1202	3.85	1250	4.11	1300	4.38	1352	4.65

## BLOWER DATA

### ZGA/ZCA120S STANDARD EFFICIENCY BELT DRIVE BLOWER – BASE UNIT

**BLOWER TABLE INCLUDES RESISTANCE FOR BASE UNIT ONLY (NO HEAT SECTION) WITH DRY INDOOR COIL AND AIR FILTERS IN PLACE. FOR ALL UNITS ADD:**

- 1 – Wet indoor coil air resistance of selected unit.
- 2 – Any factory installed options air resistance (heat section, economizer, etc.)
- 3 – Any field installed accessories air resistance (duct resistance, diffuser, etc.)

Then determine from blower table blower motor output required.

See page 17 for blower motors and drives.

See page 17 for wet coil and option/accessory air resistance data.

**MAXIMUM STATIC PRESSURE WITH GAS HEAT - 2.0 in. w.g.**

**MINIMUM AIR VOLUME REQUIRED FOR USE WITH OPTIONAL ELECTRIC HEAT (Maximum Static Pressure - 2.0 in. w.g.)**

**15 kW - 22.5 kW - 2065 cfm**

**30 kW - 2250 cfm**

**45 kW - 2625 cfm**

**60 kW - 3500 cfm**

Total Air Volume cfm	Total Static Pressure – in. w.g.																											
	0.2		0.4		0.6		0.8		1.0		1.2		1.4		1.6		1.8		2		2.2		2.4		2.6			
	RPM	BHP	RPM	BHP	RPM	BHP	RPM	BHP	RPM	BHP	RPM	BHP	RPM	BHP	RPM	BHP	RPM	BHP	RPM	BHP	RPM	BHP	RPM	BHP	RPM	BHP	RPM	BHP
2000	535	0.28	596	0.49	660	0.69	724	0.87	788	1.00	851	1.11	913	1.23	971	1.37	1025	1.52	1076	1.69	1124	1.86	---	---	---	---	---	---
2250	552	0.43	613	0.63	675	0.81	738	0.98	802	1.11	864	1.22	925	1.36	982	1.51	1036	1.68	1085	1.85	1133	2.04	1180	2.23	1228	2.44	---	---
2500	570	0.57	630	0.76	692	0.94	754	1.10	817	1.22	879	1.35	939	1.51	995	1.67	1047	1.85	1096	2.04	1143	2.23	1190	2.43	1239	2.65	---	---
2750	589	0.72	648	0.91	709	1.08	772	1.22	833	1.36	894	1.50	954	1.67	1009	1.85	1059	2.04	1108	2.24	1154	2.44	1202	2.65	1251	2.87	---	---
3000	608	0.87	668	1.05	729	1.22	791	1.37	852	1.51	912	1.67	970	1.85	1023	2.05	1073	2.25	1120	2.46	1167	2.67	1215	2.89	1265	3.11	---	---
3250	629	1.03	688	1.21	749	1.37	811	1.52	871	1.68	930	1.86	987	2.06	1039	2.27	1088	2.49	1134	2.70	1181	2.92	1229	3.14	1279	3.37	---	---
3500	651	1.20	710	1.38	772	1.54	833	1.70	892	1.88	950	2.07	1004	2.28	1055	2.51	1103	2.74	1150	2.96	1196	3.19	1245	3.42	1295	3.65	---	---
3750	674	1.36	734	1.56	796	1.73	856	1.90	914	2.10	970	2.30	1023	2.53	1072	2.78	1120	3.02	1166	3.25	1213	3.47	1262	3.71	1313	3.95	---	---
4000	699	1.55	761	1.76	822	1.94	880	2.12	936	2.33	991	2.56	1042	2.81	1090	3.07	1137	3.31	1183	3.55	1231	3.78	1281	4.03	1333	4.28	---	---
4250	726	1.77	789	1.98	849	2.16	904	2.37	959	2.59	1012	2.84	1062	3.11	1109	3.38	1156	3.63	1202	3.87	1251	4.11	1302	4.37	1354	4.63	---	---
4500	756	2.01	818	2.22	875	2.41	929	2.63	983	2.88	1034	3.15	1082	3.44	1129	3.71	1175	3.96	1222	4.21	1271	4.46	1323	4.72	1376	5.00	---	---
4750	788	2.27	848	2.47	902	2.68	955	2.92	1006	3.20	1056	3.50	1104	3.79	1150	4.06	1196	4.32	1243	4.57	1293	4.83	1345	5.09	1399	5.37	---	---
5000	822	2.54	878	2.75	929	2.98	980	3.25	1031	3.56	1079	3.87	1126	4.16	1172	4.44	1218	4.70	1266	4.95	1315	5.20	1367	5.47	1421	5.74	---	---

## BLOWER DATA

### ZGB/ZCB120S & ZG/ZC 150S STANDARD EFFICIENCY BELT DRIVE BLOWER – BASE UNIT

**BLOWER TABLE INCLUDES RESISTANCE FOR BASE UNIT ONLY (NO HEAT SECTION) WITH DRY INDOOR COIL AND AIR FILTERS IN PLACE. FOR ALL UNITS ADD:**

- 1 – Wet indoor coil air resistance of selected unit.
- 2 – Any factory installed options air resistance (heat section, economizer, etc.)
- 3 – Any field installed accessories air resistance (duct resistance, diffuser, etc.)

Then determine from blower table blower motor output required.

See page 17 for blower motors and drives.

See page 17 for wet coil and option/accessory air resistance data.

**MAXIMUM STATIC PRESSURE WITH GAS HEAT - 2.0 in. w.g.**

**MINIMUM AIR VOLUME REQUIRED FOR USE WITH OPTIONAL ELECTRIC HEAT (Maximum Static Pressure - 2.0 in. w.g.)**

**15 kW, 22.5 kW - 2065 cfm**

**30 kW - 2250 cfm**

**45 kW - 2625 cfm**

**60 kW - 3500 cfm**

Total Air Volume cfm	Total Static Pressure – in. w.g.																											
	0.2		0.4		0.6		0.8		1.0		1.2		1.4		1.6		1.8		2.0		2.2		2.4		2.6			
	RPM	BHP	RPM	BHP	RPM	BHP	RPM	BHP	RPM	BHP	RPM	BHP	RPM	BHP	RPM	BHP	RPM	BHP	RPM	BHP	RPM	BHP	RPM	BHP	RPM	BHP	RPM	BHP
2000	542	0.43	602	0.60	664	0.75	732	0.89	802	1.02	869	1.15	927	1.27	979	1.41	1029	1.57	1079	1.75	1129	1.95	1179	2.15	1230	2.37		
2250	560	0.55	619	0.71	681	0.86	748	1.00	817	1.14	882	1.27	939	1.41	991	1.57	1041	1.74	1090	1.93	1140	2.13	1190	2.35	1241	2.57		
2500	579	0.68	637	0.83	699	0.98	766	1.12	834	1.26	897	1.41	953	1.57	1005	1.74	1054	1.92	1103	2.12	1152	2.33	1202	2.55	1254	2.79		
2750	599	0.81	657	0.97	719	1.11	785	1.25	851	1.41	913	1.57	968	1.74	1020	1.93	1068	2.13	1116	2.34	1165	2.56	1215	2.78	1268	3.01		
3000	620	0.95	678	1.11	741	1.25	806	1.40	870	1.58	930	1.75	985	1.94	1036	2.14	1084	2.36	1131	2.58	1180	2.80	1230	3.02	1283	3.26		
3250	643	1.10	701	1.26	764	1.41	828	1.57	891	1.76	950	1.95	1003	2.16	1053	2.38	1100	2.61	1148	2.83	1196	3.06	1246	3.29	1299	3.52		
3500	667	1.26	726	1.43	788	1.58	851	1.77	913	1.97	970	2.17	1023	2.41	1071	2.65	1118	2.88	1165	3.11	1213	3.33	1264	3.57	1317	3.81		
3750	693	1.44	752	1.61	813	1.78	876	1.98	936	2.20	992	2.43	1043	2.68	1091	2.93	1137	3.17	1183	3.40	1232	3.64	1284	3.88	1338	4.13		
4000	720	1.65	779	1.82	840	2.00	902	2.22	961	2.46	1015	2.71	1064	2.98	1111	3.24	1156	3.48	1203	3.72	1253	3.96	1305	4.22	1359	4.48		
4250	748	1.86	807	2.04	868	2.24	929	2.48	986	2.75	1038	3.02	1086	3.30	1132	3.57	1177	3.81	1224	4.05	1274	4.31	1327	4.57	1382	4.85		
4500	778	2.09	837	2.28	898	2.51	957	2.78	1012	3.07	1062	3.37	1108	3.65	1154	3.92	1199	4.17	1247	4.41	1297	4.67	1350	4.94	1405	5.22		
4750	809	2.34	868	2.56	929	2.82	986	3.12	1038	3.43	1087	3.74	1132	4.03	1177	4.29	1223	4.54	1270	4.79	1321	5.04	1374	5.31	1428	5.58		
5000	841	2.62	901	2.87	960	3.17	1015	3.50	1065	3.83	1112	4.14	1157	4.43	1201	4.69	1247	4.94	1295	5.18	1345	5.42	1398	5.68	---	---		
5250	875	2.93	935	3.23	992	3.56	1044	3.91	1092	4.26	1138	4.57	1182	4.85	1226	5.10	1272	5.34	1320	5.57	---	---	---	---	---	---		
5500	911	3.30	969	3.63	1024	4.00	1074	4.37	1120	4.71	1165	5.02	1208	5.29	1253	5.53	---	---	---	---	---	---	---	---	---	---		
5750	948	3.71	1004	4.08	1056	4.48	1104	4.85	1148	5.19	1192	5.49	1235	5.74	---	---	---	---	---	---	---	---	---	---	---	---		
6000	985	4.18	1039	4.59	1088	5.00	1134	5.37	1177	5.69	---	---	---	---	---	---	---	---	---	---	---	---	---	---	---	---		
6250	1022	4.70	1073	5.14	1120	5.54	---	---	---	---	---	---	---	---	---	---	---	---	---	---	---	---	---	---	---	---		



## BLOWER DATA

### FACTORY INSTALLED BELT DRIVE KIT SPECIFICATIONS

Nominal hp	Maximum hp	Drive Kit Number	RPM Range
2	2.3	1	590 - 890
2	2.3	2	800 - 1105
2	2.3	3	795 - 1195
3	3.45	4	730 - 970
3	3.45	5	940 - 1200
3	3.45	6	1015 - 1300
5	5.75	10	900 - 1135
5	5.75	11	1040 - 1315
5	5.75	12	1125 - 1425

NOTE - Using total air volume and system static pressure requirements determine from blower performance tables rpm and motor output required. Maximum usable output of motors furnished are shown. In Canada, nominal motor output is also maximum usable motor output. If motors of comparable output are used, be sure to keep within the service factor limitations outlined on the motor nameplate.

NOTE - Units equipped with option are limited to a motor service factor of 1.0.

### POWER EXHAUST FAN PERFORMANCE

Return Air System Static Pressure	Air Volume Exhausted
in. w.g.	cfm
0	3175
0.05	2955
0.10	2685
0.15	2410
0.20	2165
0.25	1920
0.30	1420
0.35	1200

### FACTORY INSTALLED OPTIONS/FIELD INSTALLED ACCESSORY AIR RESISTANCE - in. w.g.

Air Volume cfm	Wet Indoor Coil			Gas Heat Exchanger			Electric Heat	Economizer	Filters	
	092	102, ZGA/ZCA120	ZGB/ZCB120 & ZG/ZC150	Standard Heat	Medium Heat	High Heat			MERV 8	MERV 13
1750	0.02	0.03	0.04	0.06	0.02	0.02	0.03	0.03	0.01	0.03
2000	0.02	0.04	0.05	0.07	0.05	0.06	0.03	0.05	0.01	0.03
2250	0.03	0.05	0.06	0.07	0.07	0.08	0.04	0.06	0.01	0.04
2500	0.03	0.05	0.07	0.09	0.10	0.11	0.04	0.08	0.01	0.05
2750	0.04	0.06	0.08	0.09	0.11	0.12	0.05	0.09	0.02	0.05
3000	0.05	0.07	0.09	0.11	0.12	0.13	0.06	0.11	0.02	0.06
3250	0.05	0.08	0.10	0.12	0.15	0.16	0.06	0.13	0.02	0.06
3500	0.06	0.09	0.11	0.12	0.16	0.17	0.09	0.15	0.03	0.07
3750	0.07	0.10	0.13	0.14	0.19	0.20	0.09	0.17	0.03	0.08
4000	0.07	0.11	0.14	0.14	0.21	0.22	0.09	0.19	0.04	0.08
4250	0.08	0.13	0.15	0.14	0.24	0.28	0.13	0.21	0.04	0.09
4500	0.09	0.14	0.17	0.15	0.26	0.32	0.14	0.24	0.04	0.09
4750	0.10	0.15	0.18	0.16	0.29	0.37	0.17	0.26	0.05	0.10
5000	0.10	0.16	0.20	0.16	0.34	0.43	0.20	0.29	0.06	0.10
5250	0.11	0.17	0.22	0.16	0.37	0.47	0.22	0.32	0.06	0.11
5500	0.12	0.19	0.23	0.18	0.44	0.54	0.25	0.34	0.07	0.12
5750	0.13	0.20	0.25	0.19	0.49	0.59	0.31	0.37	0.07	0.12
6000	0.14	0.22	0.27	0.20	0.54	0.64	0.33	0.40	0.08	0.13

**TABLE 3  
MANUFACTURER'S NUMBERS**

DRIVE NO.	DRIVE COMPONENTS					
	ADJUSTABLE SHEAVE		FIXED SHEAVE		BELT	
	BROWNING NO.	OEM PART NO.	BROWNING NO.	OEM PART NO.	BROWNING NO.	OEM PART NO.
1	1VP34x7/8	31K6901	AK61x1	100244-20	A44	44L5501
2	1VP40x7/8	79J0301	AK59x1	31K6801	AX45	100245-23
3	1VP34x7/8	31K6901	AK46x1	100244-17	A41	100245-18
4	1VP44x7/8	P-8-1488	AK74x1	100244-21	AX48	100245-50
5	1VP50x7/8	P-8-2187	AK69x1	37L4701	AX48	100245-50
6	1VP50x7/8	P-8-2187	AK64x1	12L2501	AX46	31K7101
10	1VP50x1-1/8	P-8-1977	BK77x1	49K4001	BX50	100245-49
11	1VP50x1-1/8	P-8-1977	BK67x1	100244-24	BX46	100245-48
12	1VP50x1-1/8	P-8-1977	BK62x1	100244-23	BX46	100245-48

**Cooling Start-Up**

**A-Operation**

1- Initiate first and second stage cooling demands according to instructions provided with thermostat.

**2- No Economizer Installed in Unit -**

A first-stage cooling demand (Y1) will energize compressor 1 and both condenser fans. An increased cooling demand (Y2) will energize compressor 2.

**Units Equipped With Economizer -**

When outdoor air is acceptable, a first-stage cooling demand (Y1) will energize the economizer. An increased cooling demand (Y2) will energize compressor 1 and both condenser fans. When outdoor air is not acceptable unit will operate as though no economizer is installed.

3- Units contain two refrigerant circuits or stages. See figure 15 or 16.

4- Each refrigerant circuit is separately charged with R-410A refrigerant. See unit rating plate for correct amount of charge.

5- Refer to Cooling Operation and Adjustment section for proper method to check refrigerant charge.

**B-Refrigerant Charge and Check - All-Aluminum Coil**

**WARNING-Do not exceed nameplate charge under any condition.**

This unit is factory charged and should require no further adjustment. If the system requires additional refrigerant, reclaim the charge, evacuate the system, and add required nameplate charge.

*NOTE - System charging is not recommended below 60°F (15°C). In temperatures below 60°F (15°C), the charge **must** be weighed into the system.*

If weighing facilities are not available, or to check the charge, use the following procedure:

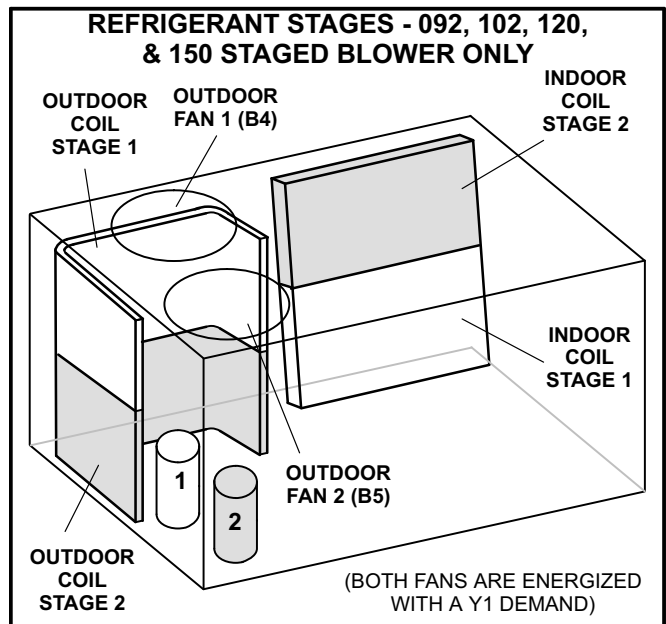

**FIGURE 15**

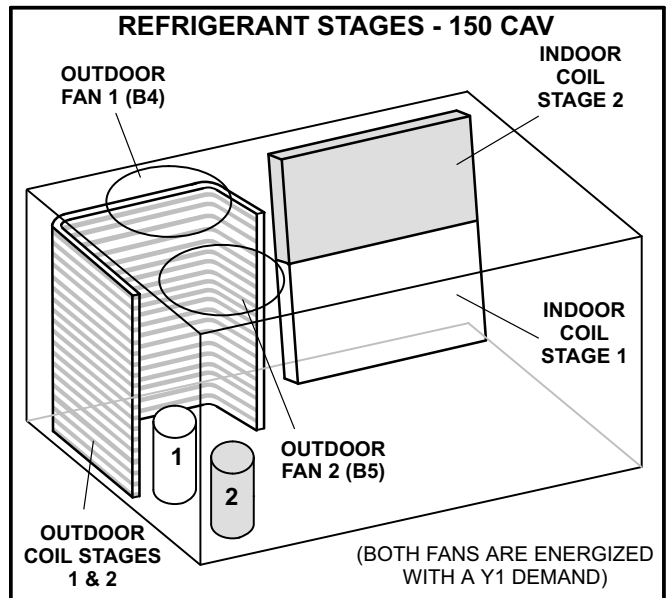

**FIGURE 16**

**IMPORTANT - Charge unit in standard cooling mode.**

- 1- Make sure outdoor coil is clean. Attach gauge manifolds and operate unit at full CFM in cooling mode with economizer disabled until system stabilizes (approximately five minutes). Make sure all outdoor air dampers are closed.
- 2- Check each system separately with all stages operating. Compare the normal operating pressures (see tables 4 - 9) to the pressures obtained from the gauges. Check unit components if there are significant differences.
- 3- Measure the outdoor ambient temperature and the suction pressure. Refer to the appropriate circuit charging curve to determine a target liquid temperature.

*Note - Pressures are listed for sea level applications.*

- 4- Use the same thermometer to accurately measure the liquid temperature (in the outdoor section).

- If measured liquid temperature is higher than the target liquid temperature, add refrigerant to the system.

- If measured liquid temperature is lower than the target liquid temperature, recover some refrigerant from the system.

- 5- Add or remove charge in increments. Allow the system to stabilize each time refrigerant is added or removed.

- 6- Continue the process until measured liquid temperature agrees with the target liquid temperature. Do not go below the target liquid temperature when adjusting charge. Note that suction pressure can change as charge is adjusted.

- 7- Example ZG/ZC 092S Circuit 1: At 95°F outdoor ambient and a measured suction pressure of 130psig, the target liquid temperature is 100.5°F. For a measured liquid temperature of 106°F, add charge in increments until measured liquid temperature agrees with the target liquid temperature.

**TABLE 4**

<b>ZGA/ZCA092S4M (Staged) &amp; ZGB/ZCB092S4B (CAV) Normal Operating Pressures</b>												
	Outdoor Coil Entering Air Temperature											
	65 °F		75 °F		85 °F		95 °F		105 °F		115 °F	
	Suct (psig)	Disc (psig)	Suct (psig)	Disc (psig)	Suct (psig)	Disc (psig)	Suct (psig)	Disc (psig)	Suct (psig)	Disc (psig)	Suct (psig)	Disc (psig)
Circuit 1	102	250	106	287	107	329	112	373	111	423	115	477
	108	253	111	291	114	333	118	380	122	431	123	486
	120	265	125	300	129	344	134	393	138	443	137	500
	134	280	138	318	144	362	148	410	153	462	155	517
Circuit 2	94	248	97	283	98	323	103	370	108	412	110	453
	98	249	101	287	104	329	109	373	115	423	119	474
	112	260	117	297	120	341	124	386	129	435	135	487
	125	275	129	312	134	354	139	403	144	452	148	501

### ZGA/ZGA092S4M (Staged) & ZGB/ZCB092S4B (CAV) Charging Curves

Outdoor Temperature (°F)

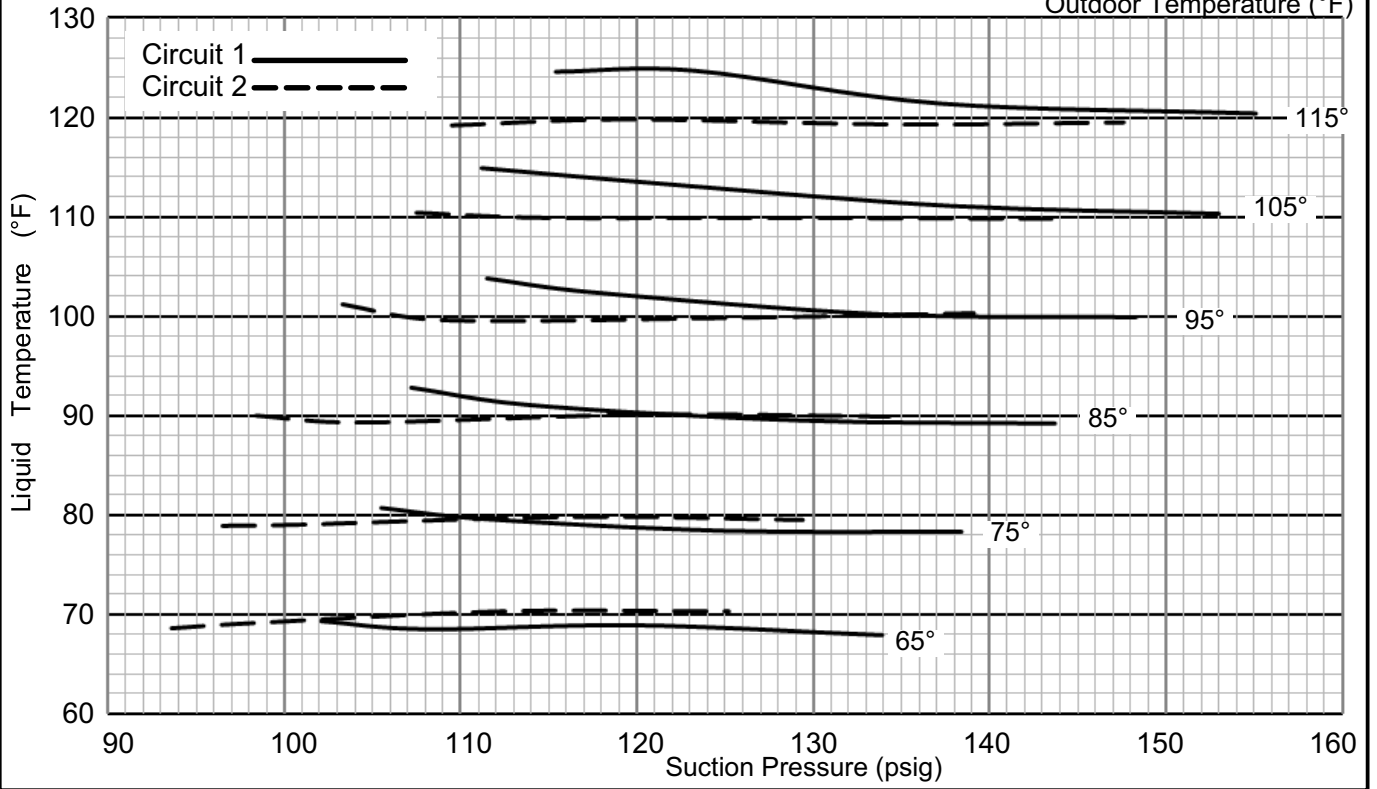

**TABLE 5**

ZGA/ZCA102S4M (Staged) & ZGB/ZCB102S4B (CAV) Normal Operating Pressures												
	Outdoor Coil Entering Air Temperature											
	65 °F		75 °F		85 °F		95 °F		105 °F		115 °F	
	Suct (psig)	Disc (psig)	Suct (psig)	Disc (psig)	Suct (psig)	Disc (psig)	Suct (psig)	Disc (psig)	Suct (psig)	Disc (psig)	Suct (psig)	Disc (psig)
Circuit 1	108	250	110	284	113	328	116	371	119	423	123	478
	114	252	118	290	121	334	124	382	127	432	131	484
	128	267	132	305	137	347	140	392	145	445	148	500
	143	285	146	322	151	363	156	411	160	461	166	517
Circuit 2	107	273	109	310	112	353	114	398	118	448	121	498
	114	277	117	315	120	357	123	403	125	447	129	496
	128	289	133	331	137	375	140	417	144	471	148	525
	144	303	148	344	153	391	157	438	162	489	166	545

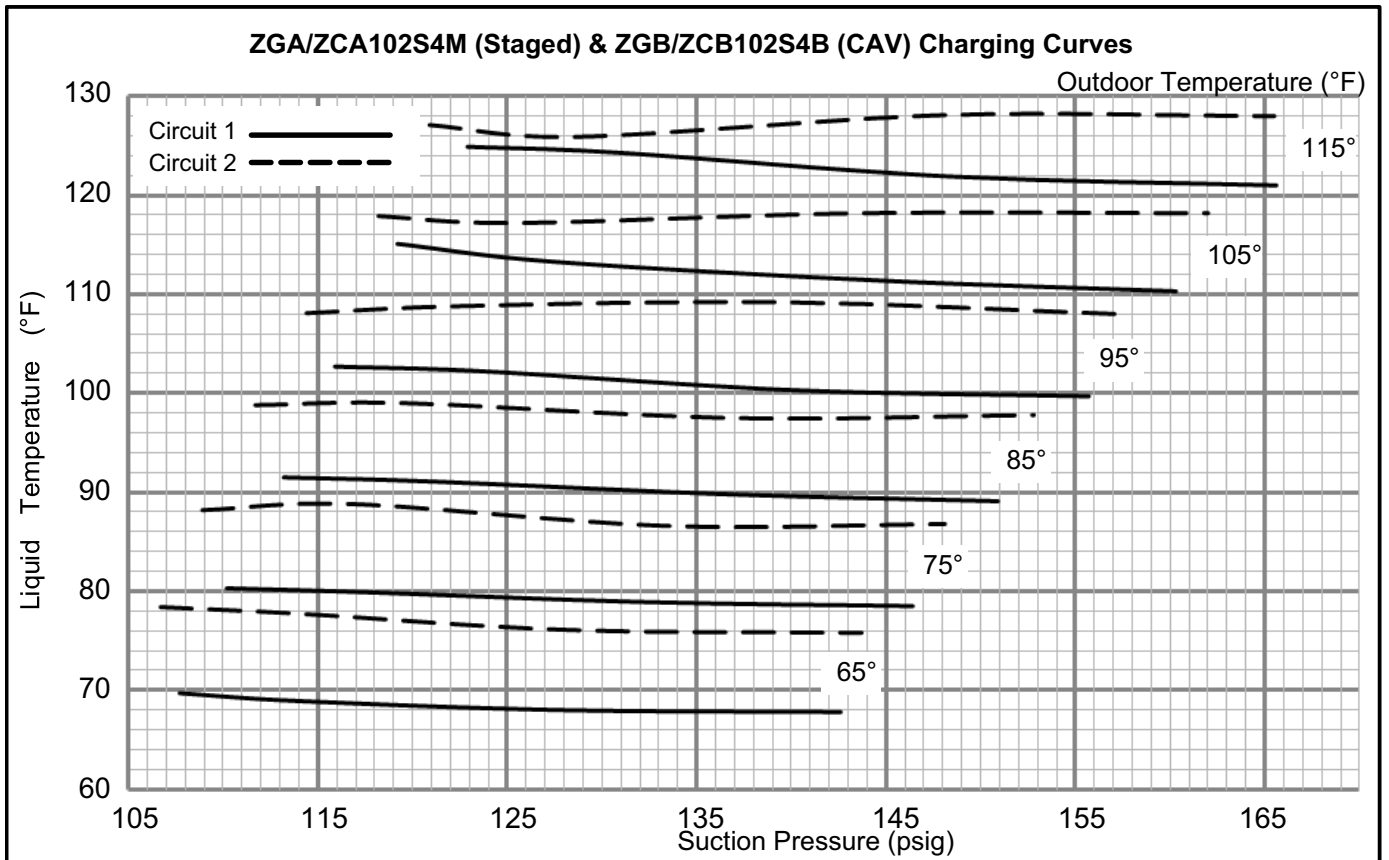
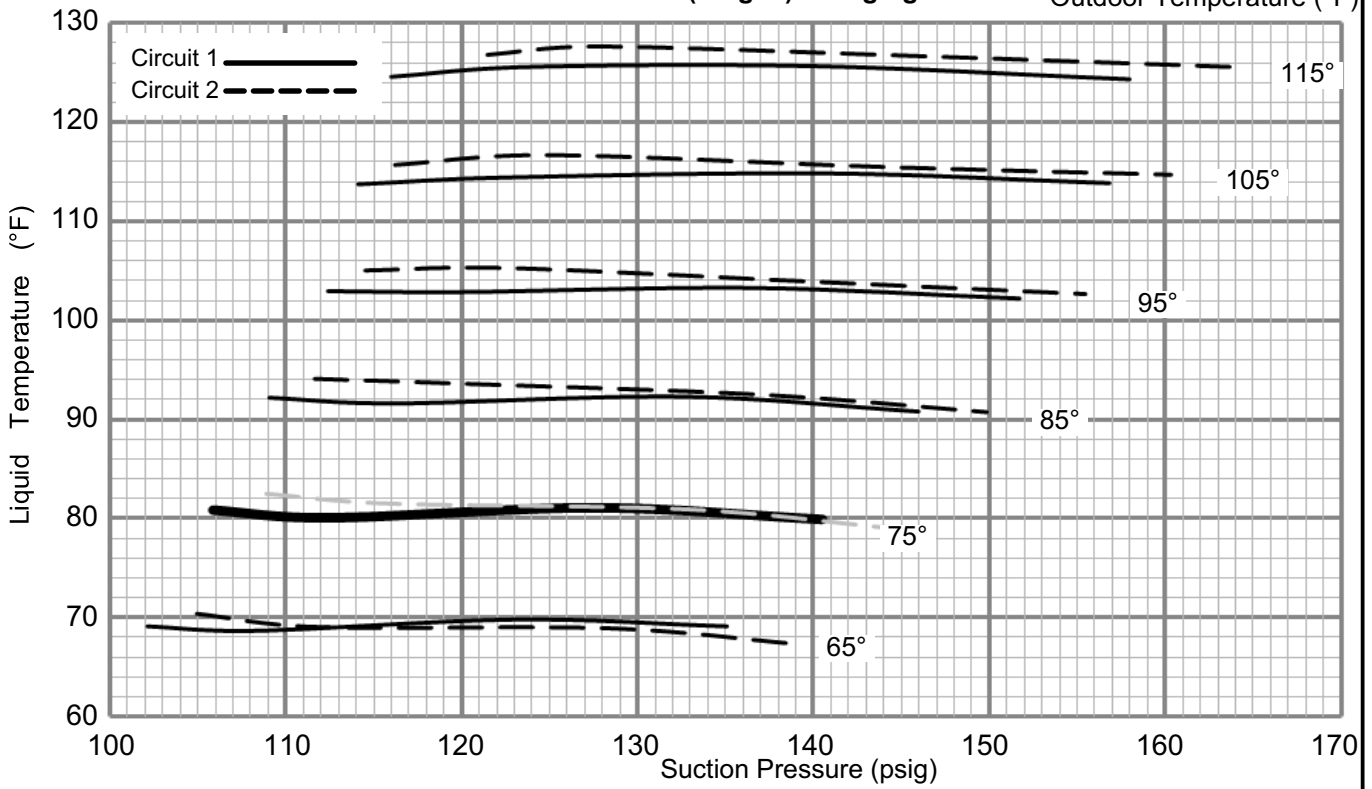

**TABLE 6**

**ZGA/ZCA120S4M (Staged) Normal Operating Pressures**

	Outdoor Coil Entering Air Temperature											
	65 °F		75 °F		85 °F		95 °F		105 °F		115 °F	
	Suct (psig)	Disc (psig)	Suct (psig)	Disc (psig)	Suct (psig)	Disc (psig)	Suct (psig)	Disc (psig)	Suct (psig)	Disc (psig)	Suct (psig)	Disc (psig)
Circuit 1	107	245	111	286	114	330	117	380	119	433	121	492
	113	249	117	252	121	333	125	382	128	440	129	501
	128	269	133	307	138	350	141	398	146	455	145	521
	140	284	145	321	151	363	157	413	162	470	163	539
Circuit 2	110	254	114	296	117	342	120	391	121	444	126	507
	117	259	121	300	125	345	128	396	130	454	133	515
	133	281	138	321	142	365	145	414	149	472	151	537
	144	289	149	328	155	371	160	423	165	481	170	546

**ZGA/ZCA120S4M (Staged) Charging Curves** Outdoor Temperature (°F)



**TABLE 7**

**ZGB/ZCB120S4B (CAV) Normal Operating Pressures**

	Outdoor Coil Entering Air Temperature											
	65 °F		75 °F		85 °F		95 °F		105 °F		115 °F	
	Suct (psig)	Disc (psig)	Suct (psig)	Disc (psig)	Suct (psig)	Disc (psig)	Suct (psig)	Disc (psig)	Suct (psig)	Disc (psig)	Suct (psig)	Disc (psig)
Circuit 1	107	253	109	290	111	333	114	379	118	428	121	482
	115	260	117	297	120	340	124	386	127	436	130	490
	130	278	134	316	137	357	141	404	145	454	146	509
	146	302	152	341	155	383	159	430	164	482	167	537
Circuit 2	107	262	109	301	112	344	115	390	119	440	121	494
	115	268	118	307	121	350	124	398	127	449	129	504
	128	275	133	320	137	363	141	412	144	462	146	521
	145	303	150	342	155	383	160	429	164	480	166	539

**ZGB/ZCB120S4B (CAV) Charging Curves**

Outdoor Temperature (°F)

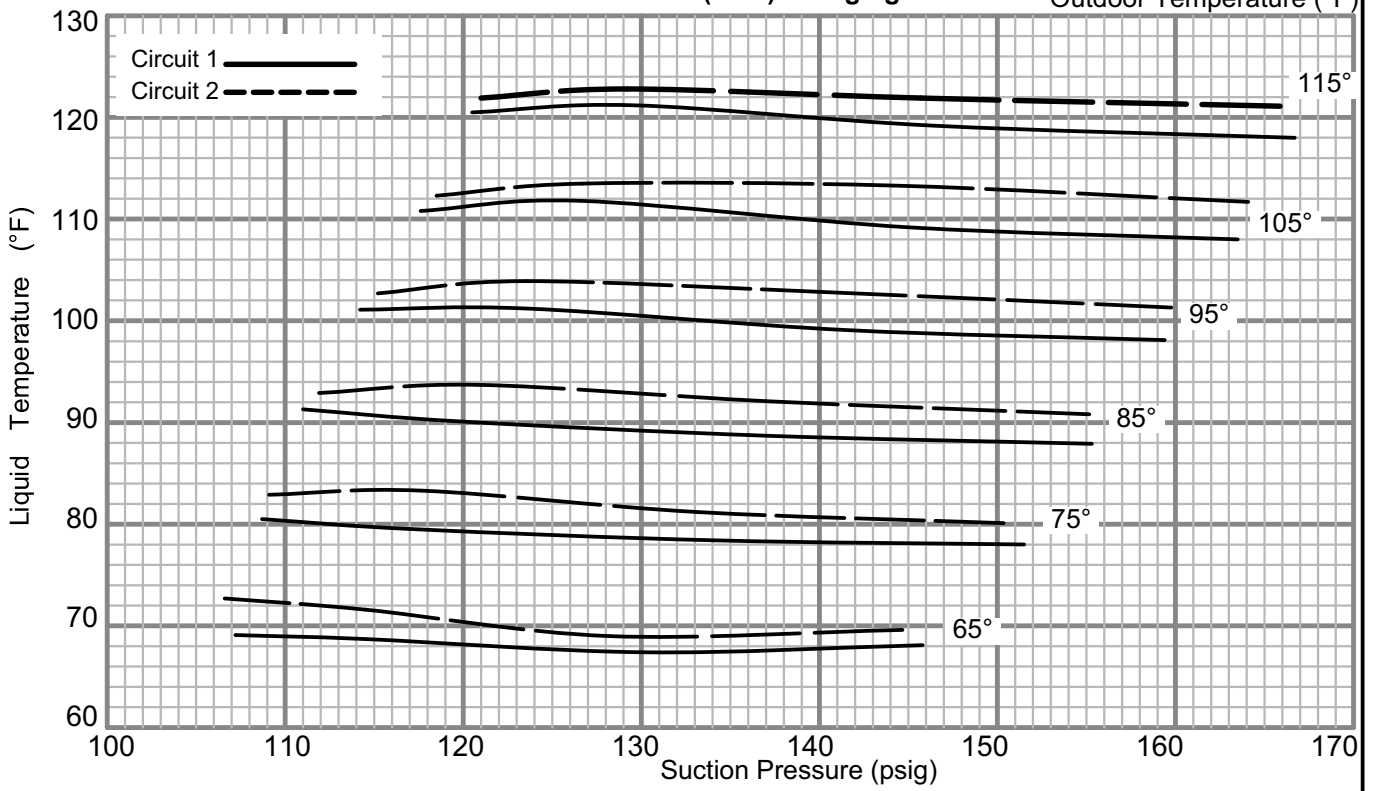
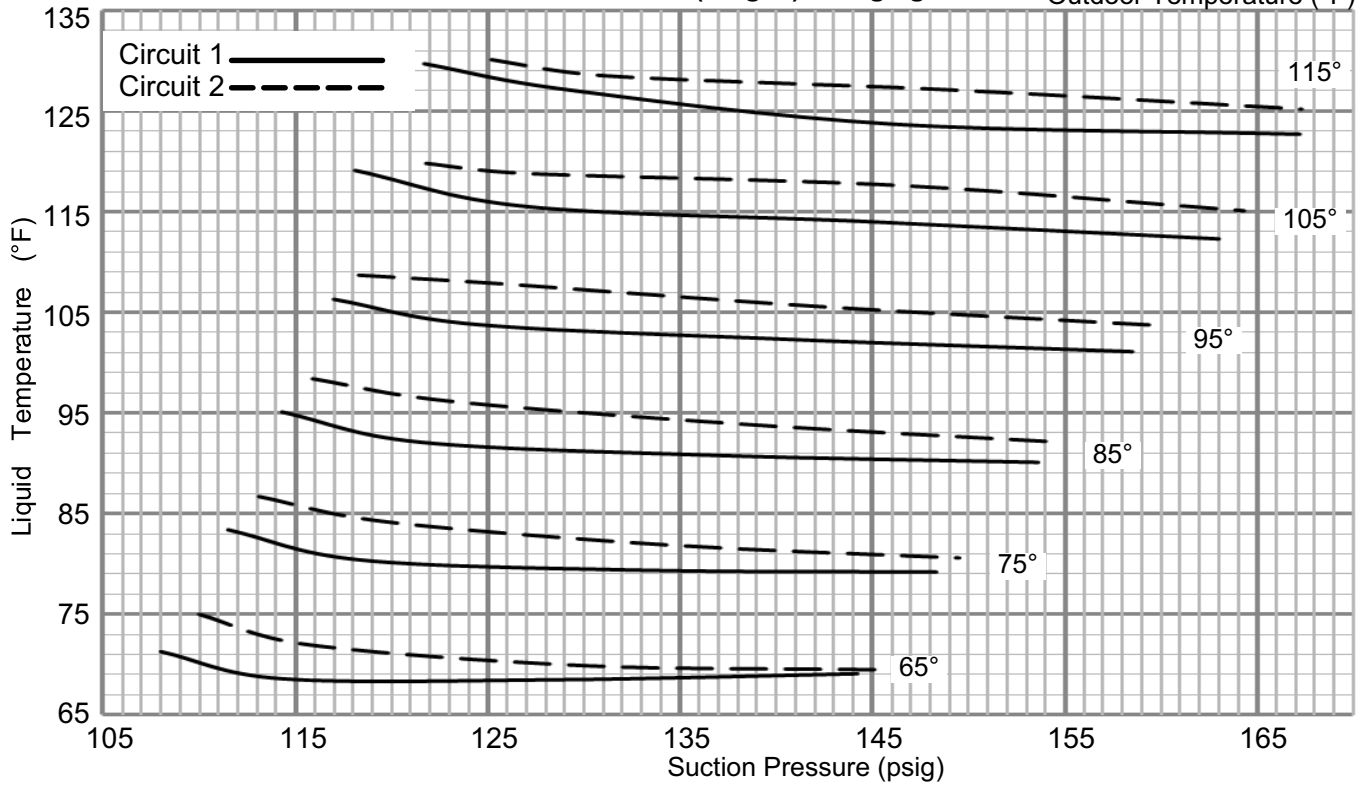

**TABLE 8**

**ZGA/ZCA150S4M (Staged) Normal Operating Pressures**

	Outdoor Coil Entering Air Temperature											
	65 °F		75 °F		85 °F		95 °F		105 °F		115 °F	
	Suct (psig)	Disc (psig)	Suct (psig)	Disc (psig)	Suct (psig)	Disc (psig)	Suct (psig)	Disc (psig)	Suct (psig)	Disc (psig)	Suct (psig)	Disc (psig)
Circuit 1	108	251	112	291	114	337	117	385	118	440	122	501
	114	254	118	293	122	338	124	385	127	440	129	496
	129	268	133	308	137	351	141	401	145	459	146	521
	144	290	148	326	154	373	159	423	163	479	167	538
Circuit 2	110	258	113	298	116	344	118	390	122	448	125	507
	116	261	120	302	123	347	126	395	127	449	131	507
	130	275	134	315	138	360	142	410	147	467	149	526
	145	294	150	332	155	379	160	429	164	484	167	542

**ZGA/ZCA150S4M (Staged) Charging Curves** Outdoor Temperature (°F)

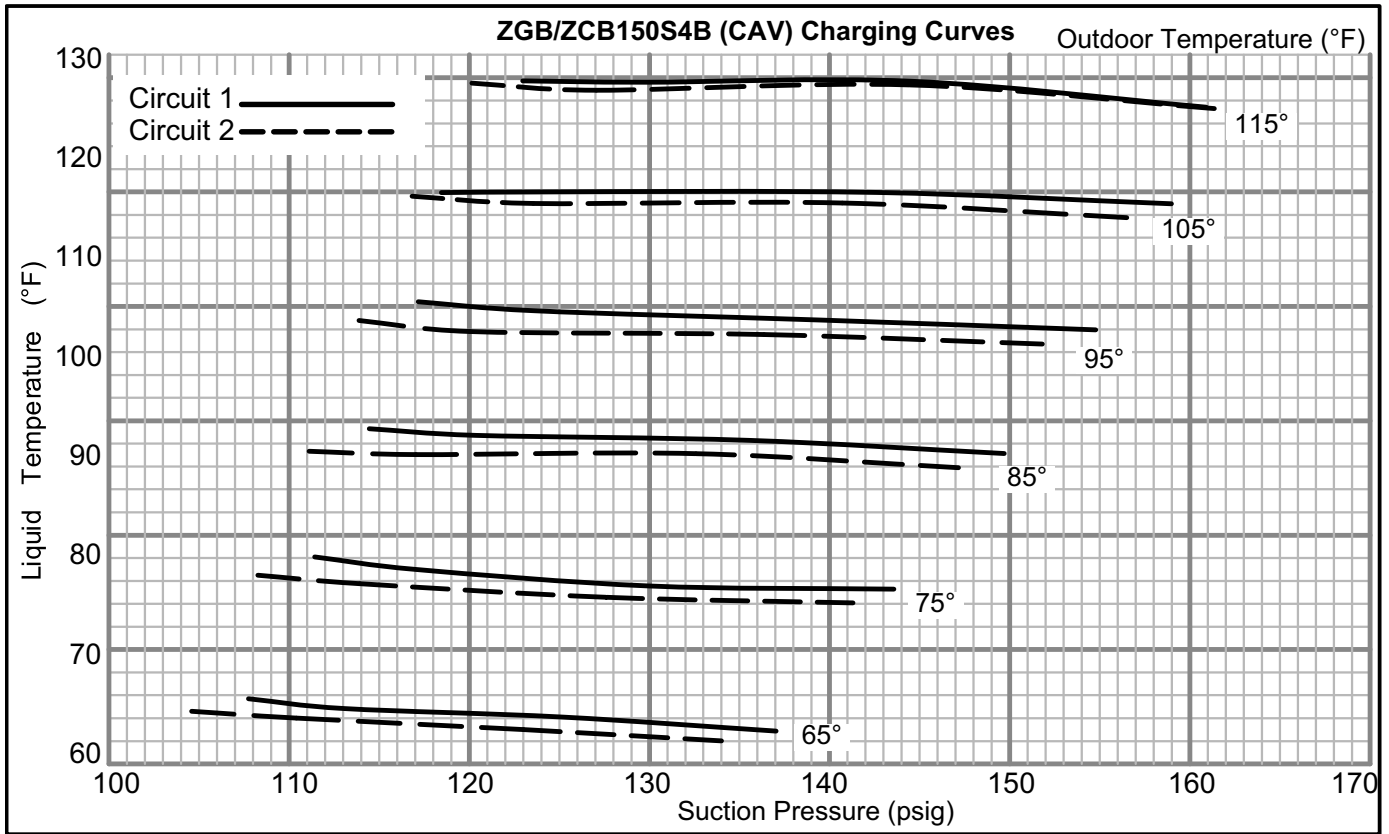



**TABLE 9**

**ZGB/ZCB150S4B (CAV) Normal Operating Pressures**

	Outdoor Coil Entering Air Temperature											
	65 °F		75 °F		85 °F		95 °F		105 °F		115 °F	
	Suct (psig)	Disc (psig)	Suct (psig)	Disc (psig)	Suct (psig)	Disc (psig)	Suct (psig)	Disc (psig)	Suct (psig)	Disc (psig)	Suct (psig)	Disc (psig)
Circuit 1	108	261	111	303	114	343	117	391	118	441	123	495
	113	264	117	305	120	349	124	394	124	443	130	498
	125	271	130	312	136	361	139	407	143	464	145	519
	137	277	144	322	150	370	155	418	159	471	161	524
Circuit 2	105	261	108	304	111	344	114	392	117	442	120	495
	110	263	114	306	117	351	120	396	124	445	127	500
	123	270	128	312	133	361	136	409	141	465	144	520
	134	277	141	323	147	372	152	420	157	473	161	524



## Gas Heat Start-Up (Gas Units)

FOR YOUR SAFETY READ BEFORE LIGHTING

### ⚠ WARNING



Electric shock hazard. Can cause injury or death. Do not use this unit if any part has been under water. Immediately call a qualified service technician to inspect the unit and to replace any part of the control system and any gas control which has been under water.

### ⚠ WARNING



Danger of explosion. Can cause injury or product or property damage. If overheating occurs or if gas supply fails to shut off, shut off the manual gas valve to the appliance before shutting off electrical supply.

### ⚠ WARNING



Electric shock hazard. Can cause injury or death. Before attempting to perform any service or maintenance, turn the electrical power to unit OFF at disconnect switch(es). Unit may have multiple power supplies.

### ⚠ WARNING

#### SMOKE POTENTIAL

The heat exchanger in this unit could be a source of smoke on initial firing. Take precautions with respect to building occupants and property. Vent initial supply air outside when possible.

BEFORE LIGHTING smell all around the appliance area for gas. Be sure to smell next to the floor because some gas is heavier than air and will settle on the floor.

Use only your hand to push in or turn the gas control knob. Never use tools. If the knob will not push in or turn by hand, do not try to repair it, call a qualified service technician. Force or attempted repair may result in a fire or explosion.

### ⚠ WARNING



Danger of explosion. Can cause injury or death. Do not attempt to light manually. Unit has a direct spark ignition system.

This unit is equipped with an automatic spark ignition system. There is no pilot. In case of a safety shutdown, move thermostat switch to **OFF** and return the thermostat switch to **HEAT** to reset ignition control.

#### A-Placing Unit In Operation

### ⚠ WARNING



Danger of explosion and fire. Can cause injury or product or property damage. You must follow these instructions exactly.

#### Gas Valve Operation for Honeywell VR8305Q or White Rodgers 36H54 (figure 17 or 18)

- 1- Set thermostat to lowest setting.
- 2- Turn off all electrical power to appliance.
- 3- This appliance is equipped with an ignition device which automatically lights the burner. Do **not** try to light the burner by hand.
- 4- Open or remove the heat section access panel.

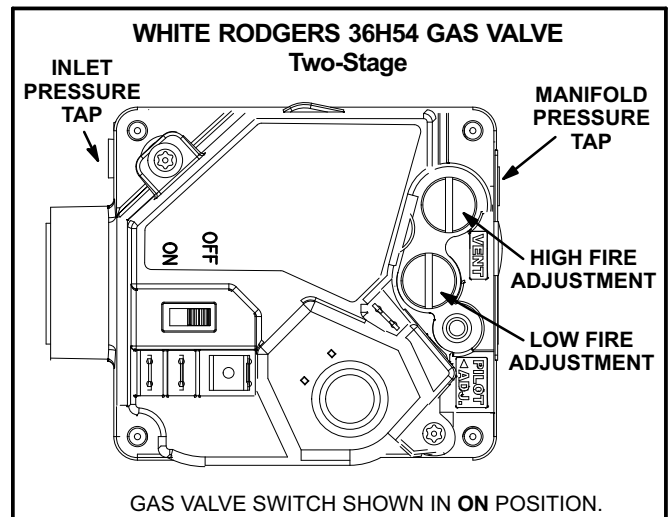

FIGURE 17

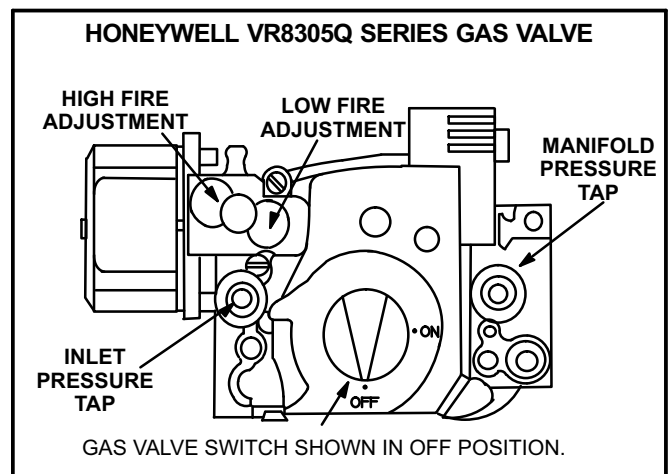





FIGURE 18

- 5- Turn gas valve switch to **OFF**. See figure 17. On Honeywell VR8305Q gas valves, turn the knob on the gas valve clockwise  to “**OFF**”. Do not force. See figure 18.
- 6- Wait five (5) minutes to clear out any gas. If you then smell gas, **STOP!** Immediately call your gas supplier from a neighbor's phone. Follow the gas supplier's instructions. If you do not smell gas, go to the next step.
- 7- Turn gas valve switch to **ON**. See figure 17. On Honeywell VR8305Q gas valves, turn the knob on the gas valve counterclockwise  to “**ON**”. Do not force. See figure 18.
- 8- Close or replace the heat section access panel.
- 9- Turn on all electrical power to appliance.
- 10- Set thermostat to desired setting.
- 11- The ignition sequence will start.
- 12- If the appliance does not light the first time (gas line not fully purged), it will attempt up to two more ignitions before locking out.
- 13- If lockout occurs, repeat steps 1 through 10.
- 14- If the appliance will not operate, follow the instructions “Turning Off Gas to Appliance” and call your service technician or gas supplier.

### Turning Off Gas to Unit

- 1- If using an electromechanical thermostat, set to the lowest setting.
- 2- Before performing any service, turn off all electrical power to the appliance.
- 3- Open or remove the heat section access panel.
- 4- Turn gas valve switch to **OFF**. On Honeywell VR8305Q gas valves, turn the knob on the gas valve clockwise  to “**OFF**”. Do not force.
- 5- Close or replace the heat section access panel.

<b>⚠ WARNING</b>	
	<b>Danger of explosion. Can cause injury or death. Do not attempt to light manually. Unit has a direct spark ignition system.</b>

## Heating Operation and Adjustments

### (Gas Units)

#### A-Heating Sequence of Operation

- 1- On a heating demand the combustion air inducer starts immediately.
- 2- Combustion air pressure switch proves inducer operation. After a 30-second pre-purge, power is

allowed to ignition control. Switch is factory set and requires no adjustment.

- 3- Spark ignitor energizes and gas valve solenoid opens.
- 4- Spark ignites gas, ignition sensor proves the flame and combustion continues.
- 5- If flame is not detected after first ignition trial, ignition control will repeat steps 3 and 4 two more times before locking out the gas valve.
- 6- For troubleshooting purposes, an ignition attempt after lock out may be re-established manually. Move thermostat to “OFF” and return thermostat switch to “HEAT” position.

### B-Ignition Control Diagnostic LED's

**TABLE 10  
IGNITION CONTROL HEARTBEAT LED STATUS**

LED Flashes	Indicates
Slow	Normal operation. No call for heat.
Fast	Normal operation. Call for heat.
Steady Off	Internal control fault OR no power to control OR Gas Valve Relay Fault.
Steady On	Control internal failure.
2	Lockout. Failed to detect or sustain flame.
3	Prove switch open or closed or rollout switch open.
4	Limit switch is open and/or limit has opened three times.
5	Flame sensed but gas valve solenoid not energized.

### C-Limit Controls

Limit controls are factory-set and are not adjustable. The primary limit is located on the bottom right of the control box.

### D-Heating Adjustment

Main burners are factory-set and do not require adjustment.

The following manifold pressures are listed on the gas valve.

- Natural Gas Units - Low Fire - 1.6” w.c. (not adjustable)
- Natural Gas Units - High Fire - 3.7” w.c.
- LP Gas Units - Low Fire - 5.5” w.c. (not adjustable)
- LP Gas Units - High Fire - 10.5” w.c.

## Electric Heat Start-Up (ZCA Units)

Optional electric heat will stage on and cycle with thermostat demand. Number of stages of electric heat will vary depending on electric heat assembly. See electric heat wiring diagram on unit for sequence of operation.

## Service

The unit should be inspected once a year by a qualified service technician.

### ⚠ CAUTION

Label all wires prior to disconnection when servicing controls. Wiring errors can cause improper and dangerous operation. Verify proper operation after servicing.

### ⚠ WARNING

This product contains a chemical known to the State of California to cause cancer, birth defects, or other reproductive harm.

#### A-Filters

Units are equipped with 20 X 24 X 2" temporary filters which must be replaced prior to building occupation. Refer to local codes or appropriate jurisdiction for approved filters.

To change filters, open filter access panel on back side of unit. See figure 19. Lift filter stop to remove filters. See figure 20.

### ⚠ WARNING

Units are shipped from the factory with temporary filters. Replace filters before building is occupied. Damage to unit could result if filters are not replaced with approved filters. Refer to appropriate codes.

Approved filters should be checked monthly and replaced when necessary. Take note of air flow direction marking on filter frame when reinstalling filters. See figure 20.

*NOTE-Filters must be U.L.C. certified or equivalent for use in Canada.*

#### B-Lubrication

All motors are lubricated at the factory. No further lubrication is required.

#### C-Burners (Gas Units)

Periodically examine burner flames for proper appearance during the heating season. Before each heating season examine the burners for any deposits or blockage which may have occurred.

Clean burners as follows:

- 1- Turn off both electrical power and gas supply to unit.
- 2- Remove burner compartment access panel.

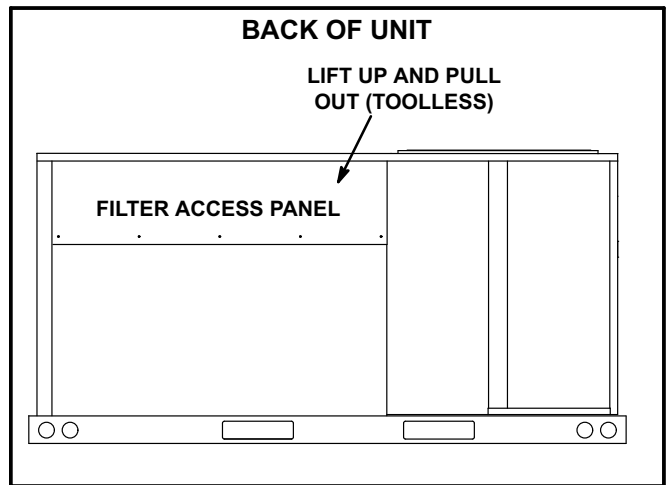

FIGURE 19

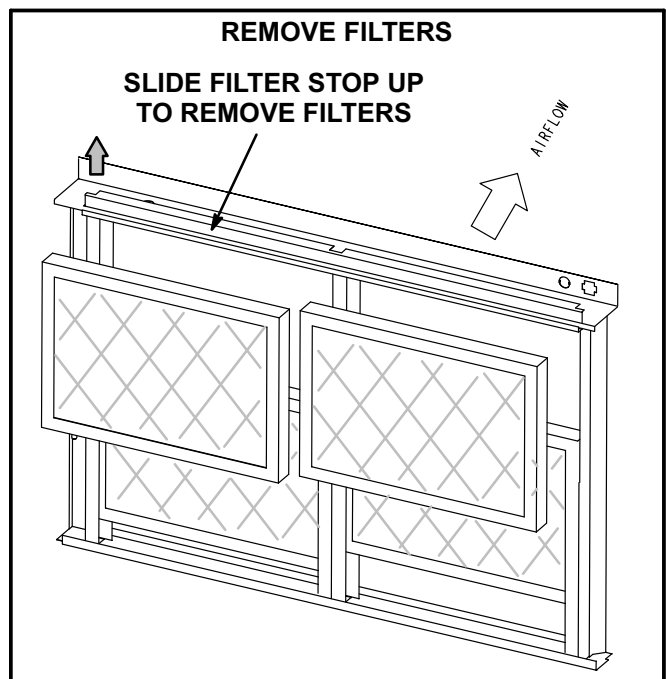
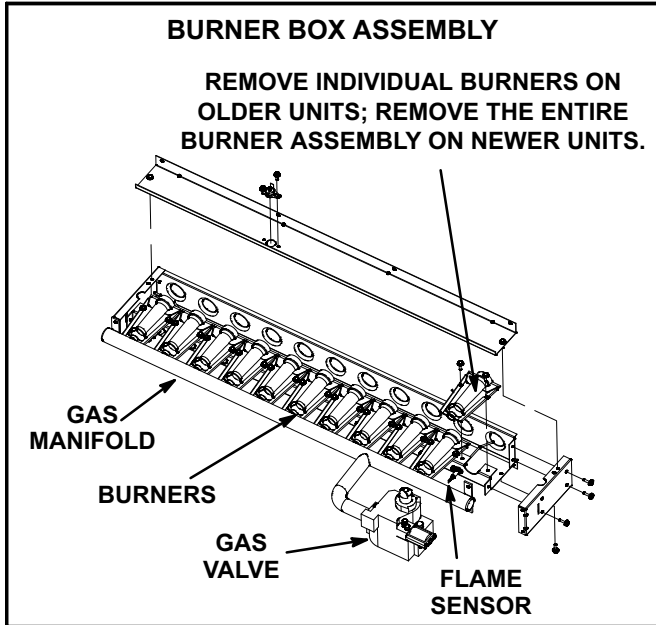
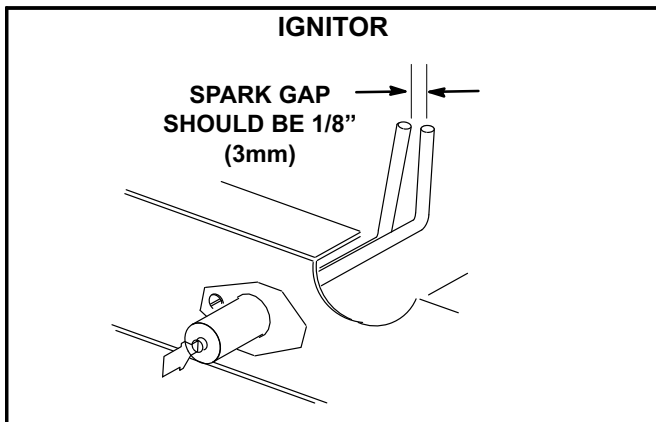

FIGURE 20

- 3- Remove screws securing burners to burner support and lift the individual burners or entire burner assembly from the orifices. See figure 21. Clean as necessary.
- 4- Locate the ignitor under the left burners. Check ignitor spark gap with appropriately sized twist drills or feeler gauges. See figure 22.



**FIGURE 21**



**FIGURE 22**

- 5- Check the alignment of the ignitor and the sensor as shown in figure 23 and table 11.
- 6- Replace burners and screws securing burner.

**⚠ WARNING**

**Danger of explosion. Can cause injury or death. Do not overtighten main burner mounting screws. Snug tighten only.**

**TABLE 11**

Dimension	Unit Btuh Input	Length - in. (mm)	
		Ignitor	Sensor
A	130K	7-3/4 (197)	11 (279)
B	180K	5 (127)	5-1/2 (140)
C	240K	2-1/4 (57)	2-3/4 (70)

- 7- Replace access panel.
- 8- Restore electrical power and gas supply. Follow lighting instructions attached to unit and use inspection port in access panel to check flame.

**D-Combustion Air Inducer (Gas Units)**

A combustion air proving switch checks combustion air inducer operation before allowing power to the gas controller. Gas controller will not operate if inducer is obstructed.

Under normal operating conditions, the combustion air inducer wheel should be checked and cleaned prior to the heating season. However, it should be examined periodically during the heating season to establish an ideal cleaning schedule. With power supply disconnected, the condition of the inducer wheel can be determined by looking through the vent opening.

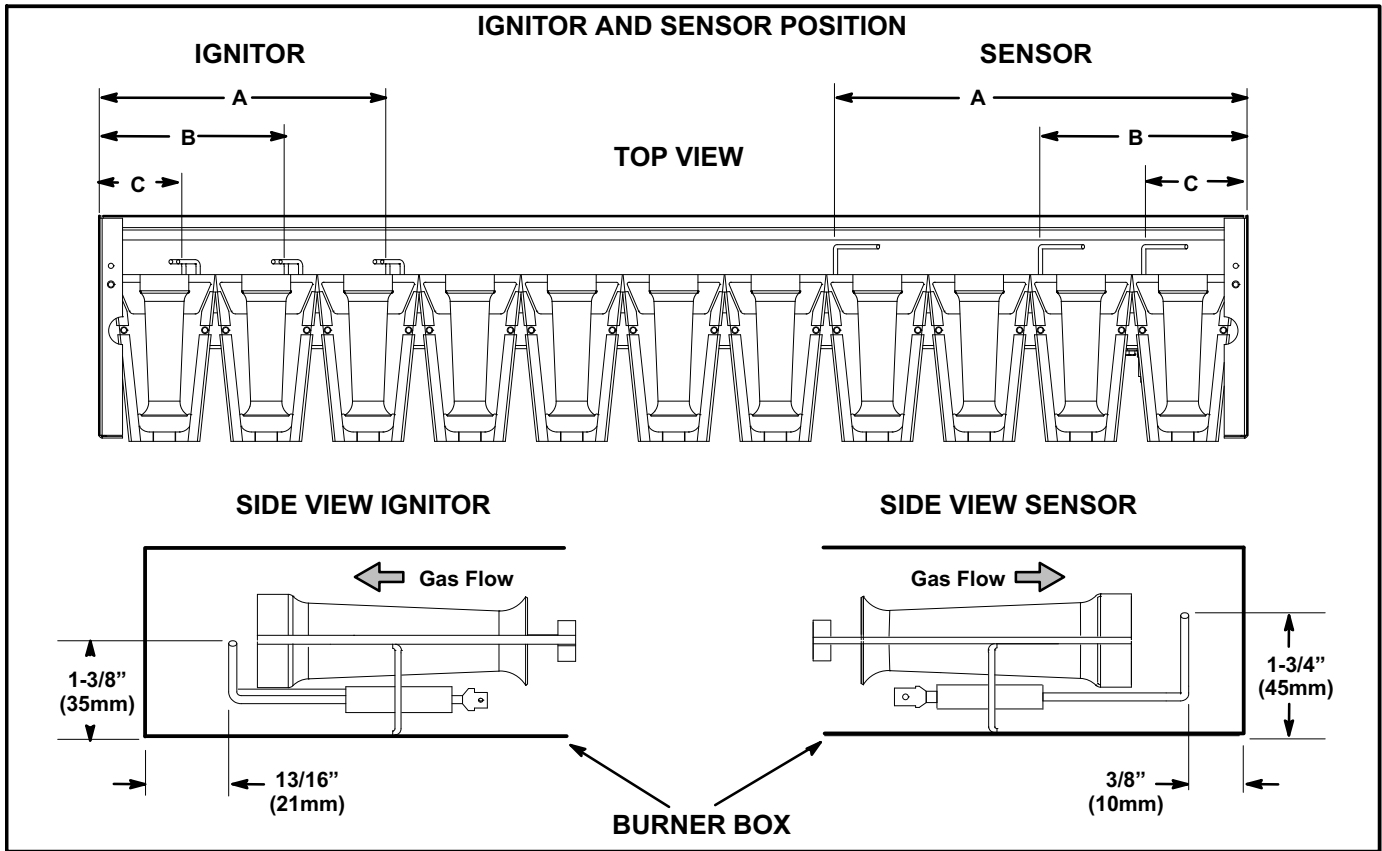

FIGURE 23

Clean combustion air inducer as follows:

- 1- Shut off power supply and gas to unit.
- 2- Disconnect pressure switch air tubing from combustion air inducer port.
- 3- Remove and retain screws securing combustion air inducer to flue box. Remove vent connector. See figure 24.

- 4- Clean inducer wheel blades with a small brush and wipe off any dust from housing. Clean accumulated dust from front of flue box cover.
- 5- Return combustion air inducer motor and vent connector to original location and secure with retained screws. It is recommended that the combustion air inducer gasket be replaced during reassembly.
- 6- Clean combustion air inlet louvers on heat access panel using a small brush.

**E-Flue Passageway and Flue Box (Gas Units)**

- 1- Remove combustion air inducer assembly as described in section D.
- 2- Remove flue box cover. Clean with a wire brush as required.
- 3- Clean tubes with a wire brush.
- 4- Reassemble the unit. The flue box cover gasket and combustion air inducer gasket should also be replaced during reassembly.

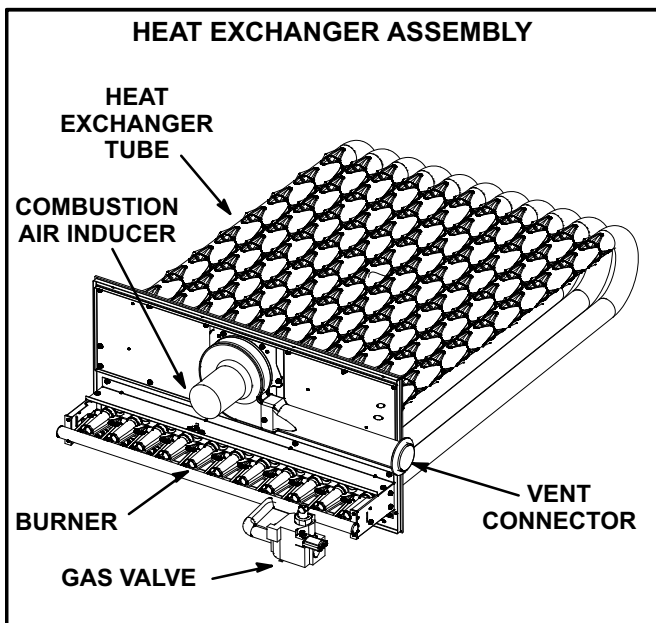

FIGURE 24

**F-Evaporator Coil**

Inspect and clean coil at beginning of each cooling season. Clean using mild detergent or commercial coil cleaner. Flush coil and condensate drain with water taking care not to get insulation, filters and return air ducts wet.

**G-Supply Air Blower Wheel**

Annually inspect supply air blower wheel for accumulated dirt or dust. Turn off power before attempting to remove access panel or to clean blower wheel.

**H-Condenser Coil**

Clean condenser coil annually with water and inspect monthly during the cooling season.

Clean the all-aluminum coil by spraying the coil steadily and uniformly from top to bottom. Do not exceed 900 psi or a 45° angle; nozzle must be at least 12 inches from the coil face. Take care not to fracture the braze between the fins and refrigerant tubes. Reduce pressure and work cautiously to prevent damage.